

GSL/GST-A

5.2 \varnothing x 20 mm

Time-Lag Fuse



Agency Approvals

Agency	Ampere Rating
UL Listed	600mA - 8A
CSA Certified	600mA - 8A
PSE	GSL: 1A - 5A (125V) 1A - 8A (250V) GST-A: 1A - 8A

Interrupting Rating

600mA - 8A:	10,000 amperes at 125V AC
600mA - 1A:	35 amperes at 250V AC
1.1A - 3.5A:	100 amperes at 250V AC
3.6A - 8A:	200 amperes at 250V AC

Product Characteristics

Operating Temperature	-55 °C to 125 °C
Material	Body: Glass Caps: Nickel Plated Brass
Leads Wire	\varnothing 0.8 mm 14A and less. \varnothing 1.0 mm for rating above 15A to 19A. \varnothing 1.2 mm for rating above 20A.

Packaging

Packaging Option	Quantity
Bulk	GSL: 1,000 pcs / box GST-A: 500 pcs / box
On Axial Tape & Reel	1,000 pcs / box

Mechanical Dimensions (mm)

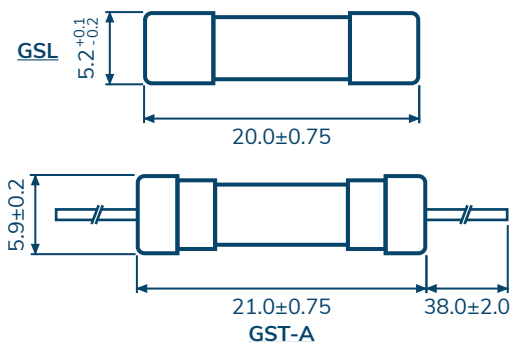

Electrical Characteristics

Ampere Rating	Opening Time			
	1 In	1.35 In	2 In	
	MIN	MAX	MIN	MAX
600mA - 20A	4 hr	1 hr	3 sec	120 sec

Catalog Number	Ampere Rating (A)	Voltage Rating (V)	Nominal Cold Resistance (Ohms)	Nominal Melting I ² t (A ² sec.)
GSL / GST-A .600	600mA	250V	0.6260	4.0008
GSL / GST-A .630	630mA		0.3925	4.4064
GSL / GST-A .700	700mA		0.3815	7.4088
GSL / GST-A .750	750mA		0.3377	9.2007
GSL / GST-A .800	800mA		0.3105	11.011
GSL / GST-A 001	1A		0.1879	14.400
GSL / GST-A 1.25	1.25A		0.1467	19.181
GSL / GST-A 1.50	1.5A		0.1048	23.962
GSL / GST-A 1.60	1.6A		0.1000	24.750
GSL / GST-A 002	2A		0.0736	59.616
GSL / GST-A 2.50	2.5A		0.0626	120.60
GSL / GST-A 003	3A		0.0514	176.26
GSL / GST-A 3.15	3.15A		0.0475	193.60
GSL / GST-A 3.50	3.5A		0.0380	198.61
GSL / GST-A 004	4A		0.0306	281.09
GSL / GST-A 005	5A		0.0216	391.64
GSL / GST-A 006	6A		0.0166	467.21
GSL / GST-A 6.30	6.3A		0.0158	477.81
GSL / GST-A 007	7A		0.0135	690.11
GSL / GST-A 7.50	7.5A		0.0122	737.70
GSL / GST-A 008	8A	0.0112	785.30	
GSL / GST-A 010	10A	0.0090	975.71	
GSL / GST-A 012	12A	0.0078	1569.7	
GSL / GST-A 015	15A	0.0051	1922.1	
GSL / GST-A 020	20A	0.0029	3553.6	