

# LSUM 051R3C 0166F EA

The Ultracapacitor, also known as double-layer capacitor, stores energy by means of a static charge as opposed to a battery, which uses an electrochemical reaction.

The Ultracapacitor is used for energy storage applications which undergo very frequent charge and discharge cycles at high current and short duration. Its life can be as high as one million cycles. It features a wide operating temperature range, from -40°C to 65°C, making it an ideal energy storage device for extreme environments.

It can be applied in wind power, hybrid systems, industrial automation, power backup and stabilization. Imagination is its only boundary.



## PERFORMANCE SPECIFICATIONS

Rated Voltage(Nominal)	51.3 V
Surge Voltage	54.0 V
Max. Series Voltage	1500 V
Capacitance	166 F
Capacitance Tolerance	-0% / + 20%
Max. ESR DC	5 mΩ
Typical ESR DC	3.7 mΩ
Total Energy	60.7 Wh
Max. Current <sup>1</sup>	2,300 A
Leakage Current <sup>2</sup>	< 5 mA
Rated voltage of Cells	2.85 V
Capacitance of Cells	3000 F
Number of Cells	18 Series

<sup>1</sup> The stated maximum peak current should not be used in normal operation and is only provided as a reference value.

<sup>2</sup> The module leakage current is based on the calculated value. It may change depending on the cell balancing configuration.

## LIFE INFORMATION

Endurance Life (65 °C)	1500hr
Capacitance Change <sup>3</sup>	< 20%
ESR DC Change <sup>4</sup>	< 100%
Projected Life (25 °C)	10 Years
Capacitance Change <sup>3</sup>	< 20%
ESR DC Change <sup>4</sup>	< 100%
Projected Cycle Life (25 °C) <sup>5</sup>	1,000,000 Cycles
Capacitance Change <sup>3</sup>	< 20%
ESR DC Change <sup>4</sup>	< 100%
Shelf Life (25 °C) <sup>6</sup>	4 Years

<sup>3</sup> Decrease from minimum initial value.

<sup>4</sup> Increase from maximum initial value.

<sup>5</sup> Cycle Life may vary for different working conditions. (e.g. voltage or temperature)

<sup>6</sup> Stored uncharged state under appropriate storage conditions.

## THERMAL SPECIFICATIONS

Max. Continuous Current ΔT=15 °C <sup>7</sup>	60 A
Max. Continuous Current ΔT=40 °C <sup>7</sup>	100 A
Thermal Resistance (°C/W) <sup>8</sup>	0.83 °C/W

<sup>7</sup>Initial state value.

<sup>8</sup>The specification is calculated under limited conditions.

## SAFETY INFORMATION

Short Circuit Current <sup>9</sup>	10,200 A
Isolation Voltage (DC, Terminal - Case)	4.0 kV
Certification	ROHS, REACH, UL810A

<sup>9</sup>Calculated value. Do not use as an operating current.

## MONITORING INFORMATION

Temperature Sensor	PTC thermistor
Temperature Interface	Analog
Connector	LAB 1143-04
Cell Voltage Monitoring	Over Voltage Alarm
Cell Balancing	Active, Passive

**MECHANICAL SPECIFICATIONS**

Length	590.4 ± 1.0 mm
Width	136.0 ± 1.0 mm
Height	171.0 ± 1.0 mm
Weight	Max. 12.0 kg

**PHYSICAL SPECIFICATIONS**

Power Terminals	M8 / M10
Recommended Torque (Terminal)	20Nm / 30Nm
Vibration & Shock Protection <sup>10</sup>	-
Environment Protection <sup>10</sup>	-

<sup>10</sup>The specifications are for tests with limited conditions and may differ under actual conditions.

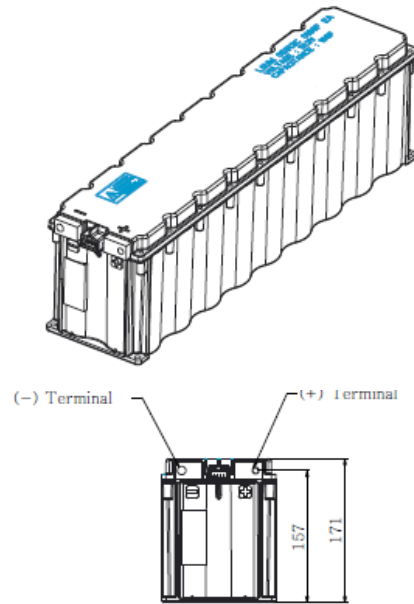
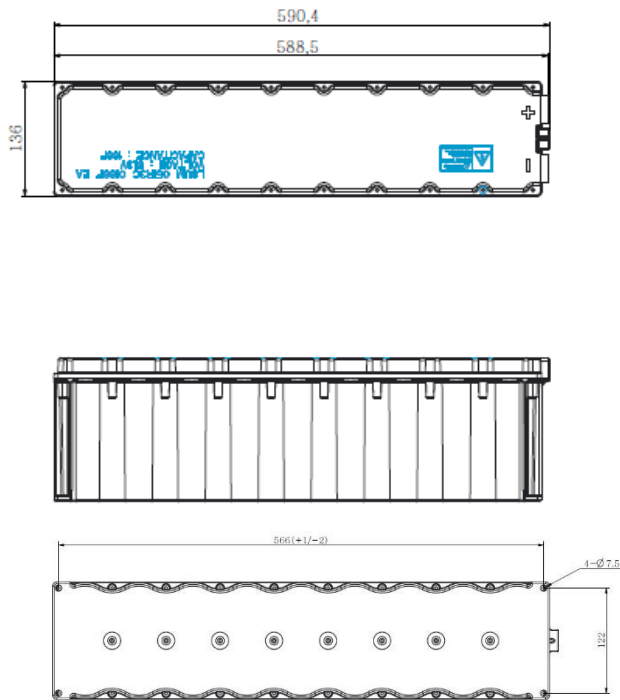

**Markings**

- Positive / Negative terminal
- Serial number
- Part number
- Warning marking

**Accessories**

Notice : Product dimensions and specifications may change without notice. Please contact LS Materials for any technical specifications.