



GF200CU120T2VH

GF200CL120T2VH

IGBT Module

Features:

- Non Punch Through (NPT) Technology
- Short Circuit Rated >10 μ s
- Low Saturation Voltage
- Low Switching Loss
- 100% RBSOA Tested (2 \times I_c)
- Low Stray Inductance
- Lead Free, Compliant with RoHS Requirement

Applications:

- Welding Machine、Cutting Machine
- Plating Power Supply、Induction Heating
- SMPS、UPS

Circuit Diagram

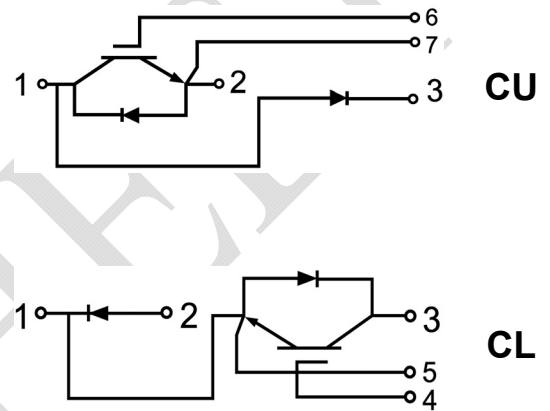

IGBT, Brake-Chopper

Maximum Rated Values of IGBT (T_C=25 $^{\circ}$ C unless otherwise specified)

V _{CES}	Collector-Emitter Blocking Voltage		1200	V
V _{GES}	Gate-Emitter Voltage		\pm 20	V
I _C	Continuous Collector Current	T _C =80 $^{\circ}$ C	200	A
		T _C =25 $^{\circ}$ C	400	A
I _{CM}	Repetitive Peak Collector Current	T _J =150 $^{\circ}$ C	400	A
t _{SC}	Short Circuit Withstand Time		>10	μ s
P _D	Maximum Power Dissipation per leg	T _C =25 $^{\circ}$ C T _{Jmax} =150 $^{\circ}$ C	1730	W



Electrical Characteristics of IGBT ($T_C=25^\circ\text{C}$ unless otherwise specified)

Static Characteristics

Symbol	Description	Conditions	Min.	Typ.	Max.	Units
$V_{GE(th)}$	Gate-Emitter Threshold Voltage	$I_C=8\text{mA}$, $V_{CE}=V_{GE}$	5.0	5.9	6.5	V
$V_{CE(sat)}$	Collector-Emitter Saturation Voltage	$I_C=200\text{A}$, $V_{GE}=15\text{V}$	$T_J=25^\circ\text{C}$	3.15	3.50	V
			$T_J=125^\circ\text{C}$	3.90		V
I_{CES}	Collector-Emitter Leakage Current	$V_{GE}=0\text{V}$, $V_{CE}=V_{CES}$, $T_J=25^\circ\text{C}$			1	mA
I_{GES}	Gate-Emitter Leakage Current	$V_{GE}=\pm 20\text{V}$, $V_{CE}=0\text{V}$, $T_J=25^\circ\text{C}$			200	nA
C_{ies}	Input Capacitance	$V_{CE}=25\text{V}$, $V_{GE}=0\text{V}$, $f=100\text{kHz}$		15.2		nF
C_{oes}	Output Capacitance			1.42		nF
C_{res}	Reverse Transfer Capacitance			0.70		nF

Switching Characteristics

Symbol	Description	Conditions	Min.	Typ.	Max.	Units
$t_{d(on)}$	Turn-on Delay Time	$V_{CC}=600\text{V}$, $I_C=200\text{A}$, $R_{Gon}=7.5\Omega$, $V_{GE}=\pm 15\text{V}$, Inductive Load	$T_J=25^\circ\text{C}$		563	ns
			$T_J=125^\circ\text{C}$		564	
t_r	Rise Time		$T_J=25^\circ\text{C}$		110	ns
			$T_J=125^\circ\text{C}$		109	
$t_{d(off)}$	Turn-off Delay Time	$V_{CC}=600\text{V}$, $I_C=200\text{A}$, $R_{Goff}=7.5\Omega$, $V_{GE}=\pm 15\text{V}$, Inductive Load	$T_J=25^\circ\text{C}$		544	ns
			$T_J=125^\circ\text{C}$		572	
t_f	Fall Time		$T_J=25^\circ\text{C}$		144	ns
			$T_J=125^\circ\text{C}$		159	
E_{on}	Turn-on Switching Loss	$V_{CC}=600\text{V}$, $I_C=200\text{A}$, $R_{Gon}=7.5\Omega$, $V_{GE}=\pm 15\text{V}$, $di/dt=1600\text{A}/\mu\text{s}$ ($T_J=125^\circ\text{C}$), Inductive Load	$T_J=25^\circ\text{C}$		14.6	mJ
			$T_J=125^\circ\text{C}$		17.2	
E_{off}	Turn-off Switching Loss		$T_J=25^\circ\text{C}$		8.4	mJ
			$T_J=125^\circ\text{C}$		11.2	
Q_g	Total Gate Charge	$V_{GE}=+15\text{V}\dots-15\text{V}$	$T_J=25^\circ\text{C}$		2.2	μC
R_g	Gate Resistance		$T_J=25^\circ\text{C}$		2.35	Ω
RBSOA	$I_C=400\text{A}$, $V_{CC}=1050\text{V}$, $V_p=1200\text{V}$, $R_G=7.5\Omega$, $V_{GE}=+15\text{V}$ to 0V , $T_J=125^\circ\text{C}$		Trapezoid			
SC Data	$V_{CC}=600\text{V}$, $t_p=10\mu\text{s}$, $V_{GE}=\pm 15\text{V}$, $R_{Gon}=7.5\Omega$, $R_{Goff}=7.5\Omega$, $T_J=125^\circ\text{C}$		10			μs
$R_{\theta JC}$	IGBT Thermal Resistance: Junction-to-Case				0.072	$^\circ\text{C}/\text{W}$



Diode, Reverse

Maximum Rated Values of Diode ($T_C=25^\circ\text{C}$ unless otherwise specified)

V_{RRM}	Repetitive Peak Reverse Voltage	1200	V
I_F	Diode Continuous Forward Current	150	A
I_{FM}	Diode Maximum Forward Current	300	A

Electrical Characteristics of Diode ($T_C=25^\circ\text{C}$ unless otherwise specified)

Symbol	Description	Conditions	Min.	Typ.	Max.	Units
V_{FM}	Forward Voltage	$I_F=150\text{A}$	$T_J=25^\circ\text{C}$	2.70		V
			$T_J=125^\circ\text{C}$	2.70		
t_{rr}	Reverse Recovery Time		$T_J=25^\circ\text{C}$	132		ns
			$T_J=125^\circ\text{C}$	265		
I_{rr}	Peak Reverse Recovery Current	$I_F=150\text{A}$, $-diF/dt=1150\text{A}/\mu\text{s}(T_J=125^\circ\text{C})$, $V_{rr}=600\text{V}$, $V_{GE}=-15\text{V}$	$T_J=25^\circ\text{C}$	78.2		A
			$T_J=125^\circ\text{C}$	109.4		
Q_{rr}	Reverse Recovery Charge		$T_J=25^\circ\text{C}$	5.6		μC
			$T_J=125^\circ\text{C}$	12.2		
E_{rec}	Reverse Recovery Energy		$T_J=25^\circ\text{C}$	2.16		mJ
			$T_J=125^\circ\text{C}$	4.76		
$R_{\theta JC}$	Diode Thermal Resistance: Junction-to-Case				0.205	$^\circ\text{C}/\text{W}$

Diode, Brake-Chopper

Maximum Rated Values ($T_C=25^\circ\text{C}$ unless otherwise specified)

V_{RRM}	Repetitive Peak Reverse Voltage	1200	V
I_F	Diode Continuous Forward Current	200	A
I_{FM}	Diode Maximum Forward Current	400	A



Electrical Characteristics of Diode ($T_C=25^\circ\text{C}$ unless otherwise specified)

Symbol	Description	Conditions		Min.	Typ.	Max.	Units	
V_{FM}	Forward Voltage	$I_F=200A$, $V_{GE}=15V$	$T_J=25^\circ\text{C}$		2.50		V	
			$T_J=125^\circ\text{C}$		2.60			
t_{rr}	Reverse Recovery Time	$I_F=200A$, $di/dt=1270A/\mu s$ ($T_J=125^\circ\text{C}$), $V_{rr}=600V$, $V_{GE}=-15V$	$T_J=25^\circ\text{C}$		210		ns	
			$T_J=125^\circ\text{C}$		345			
I_{rr}	Peak Reverse Recovery Current		$T_J=25^\circ\text{C}$		59.5		A	
			$T_J=125^\circ\text{C}$		81.1			
Q_{rr}	Reverse Recovery Charge		$T_J=25^\circ\text{C}$		5.9		μC	
			$T_J=125^\circ\text{C}$		13.2			
E_{rec}	Reverse Recovery Energy		$T_J=25^\circ\text{C}$		1.96		mJ	
			$T_J=125^\circ\text{C}$		4.04			
$R_{\theta JC}$	Diode Thermal Resistance: Junction-to-Case					0.166	$^\circ\text{C/W}$	

Module

Symbol	Description	Min.	Typ.	Max.	Units
V_{iso}	Isolation Voltage (All Terminals Shorted)	$f=50\text{Hz}$, 1minute	2500		V
L_{sCE}	Stray Inductance Module			20	nH
T_J	Maximum Junction Temperature			150	$^\circ\text{C}$
T_{JOP}	Maximum Operating Junction Temperature Range		-40	+125	$^\circ\text{C}$
T_{stg}	Storage Temperature		-40	+125	$^\circ\text{C}$
CTI	Comparative Tracking Index		200		
$R_{\theta CS}$	Case-to-Sink Thermally (Conductive Grease Applied)			0.03	$^\circ\text{C/W}$
T	Power Terminals Screw:M6		3.0	5.0	N·m
T	Mounting Screw:M6		4.0	6.0	N·m
G	Weight			300	g



Ordering Information Table

Device code	G	F	200	CU	120	T2V	H
	①	②	③	④	⑤	⑥	⑦

- ① - IGBT Module
- ② - NPT, Fast IGBT
- ③ - Rated Current (200=200A)
- ④ - Circuit Configuration: Chopper, CU(Diode on High Side) / CL(Diode on Low Side)
- ⑤ - Rated Voltage (120=1200V)
- ⑥ - Package Type
- ⑦ - Test Level (Pass the Important Reliability Test-Industrial Grade)

DATA SHEET

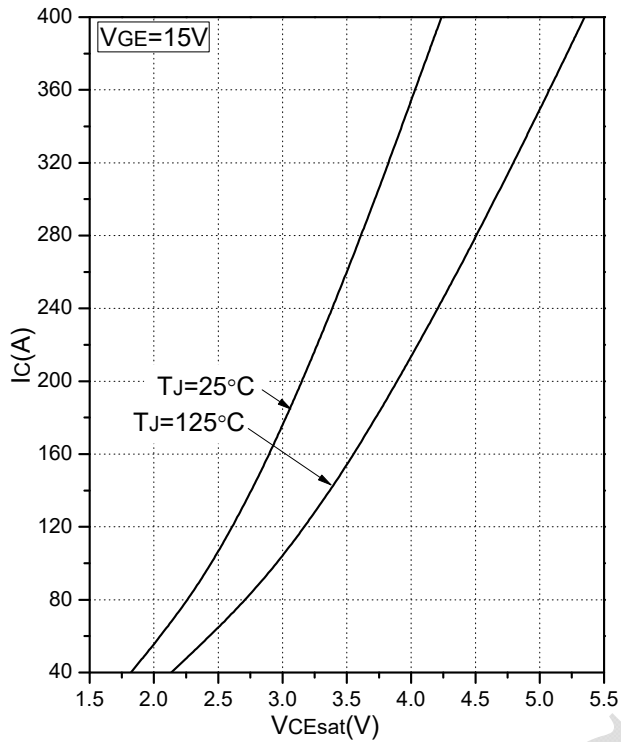

Fig.1 Typical Saturation Voltage Characteristics

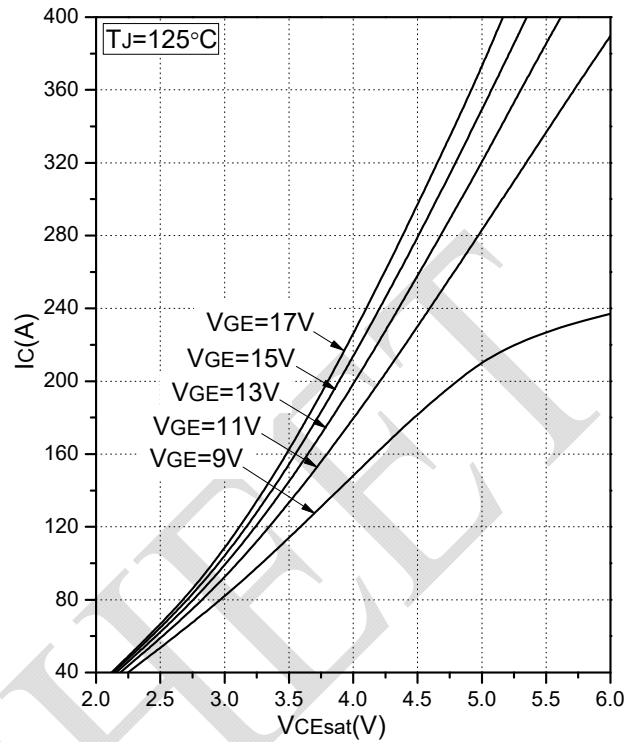

Fig.2 Typical Output Characteristics

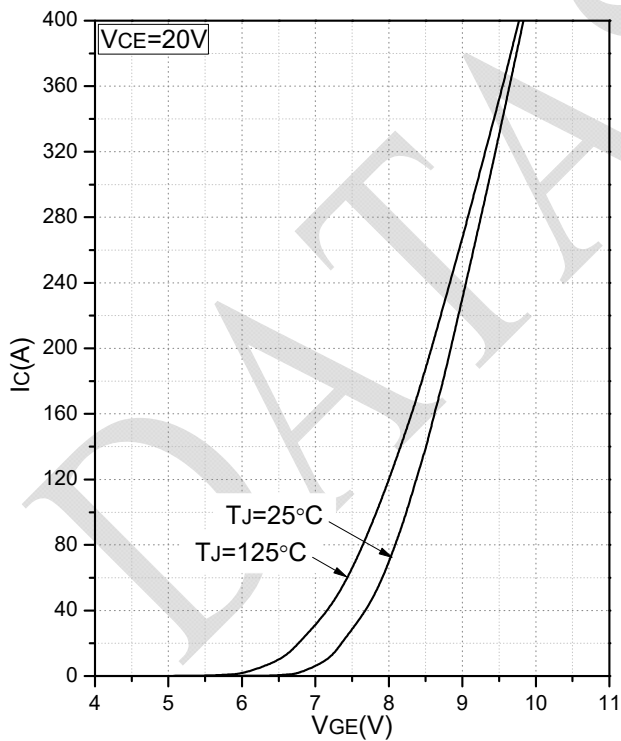

Fig.3 Transfer Characteristic

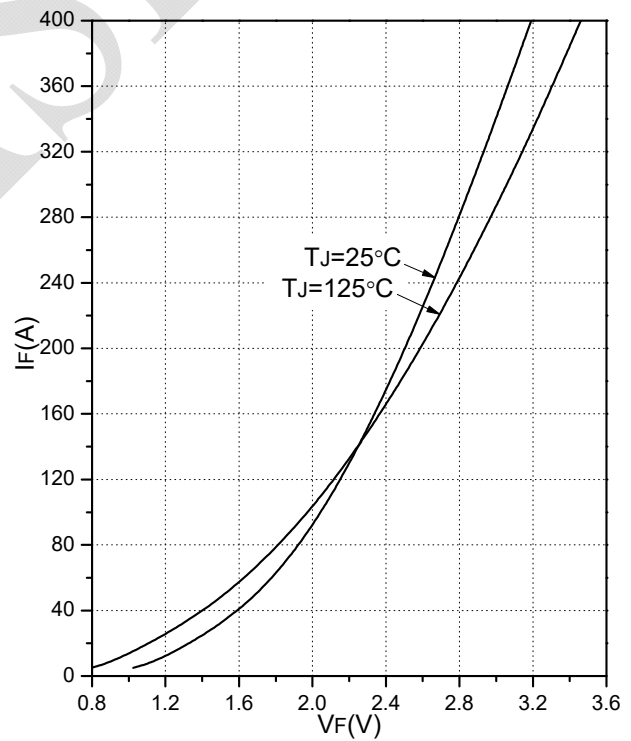

Fig.4 Forward Characteristics of Diode (Diode, Chopper)

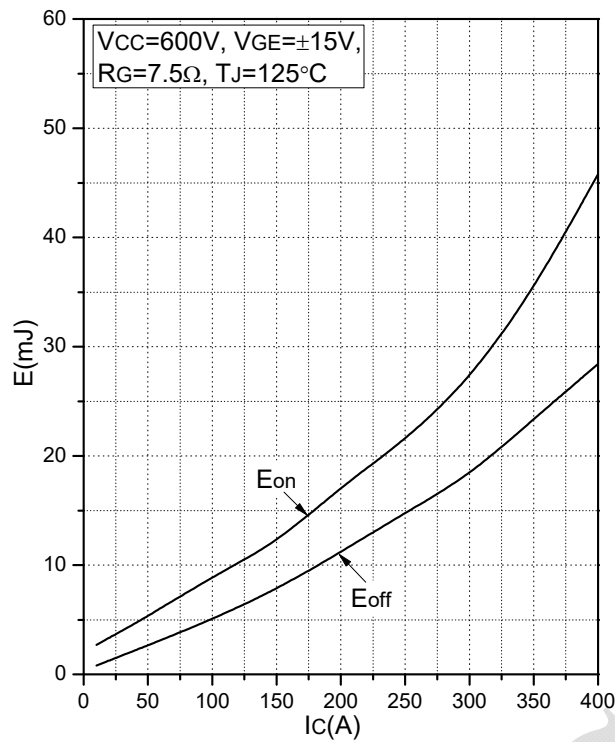

Fig.5 Typical Switching Loss vs. Collector Current

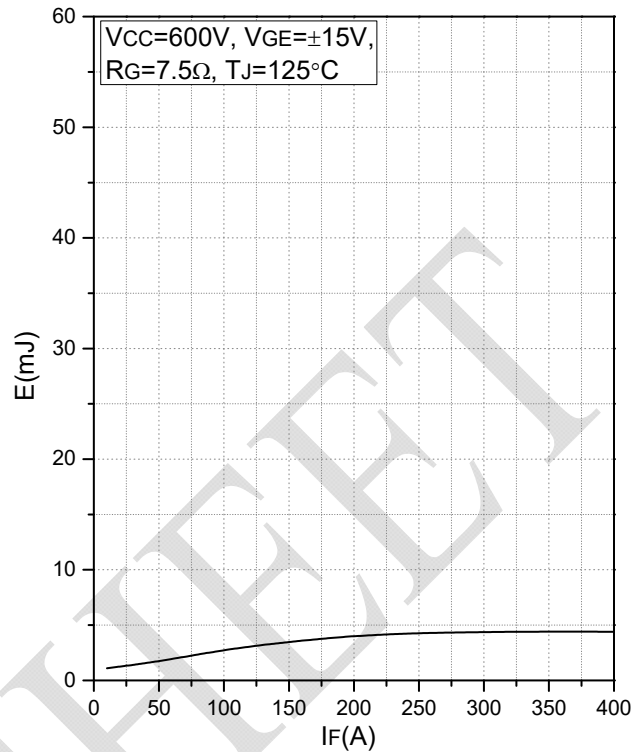

Fig.6 Typical Switching Loss vs. Forward Current (Diode, Chopper)

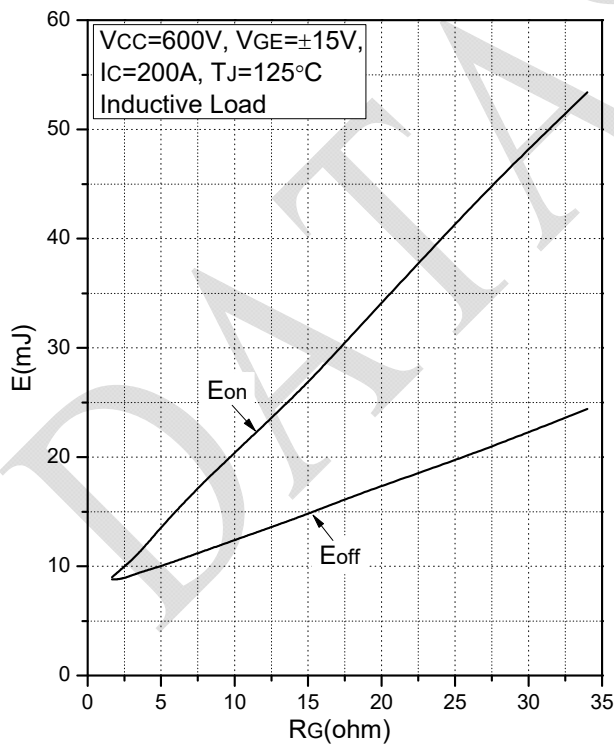

Fig.7 Typical Switching Loss vs. Gate Resistance

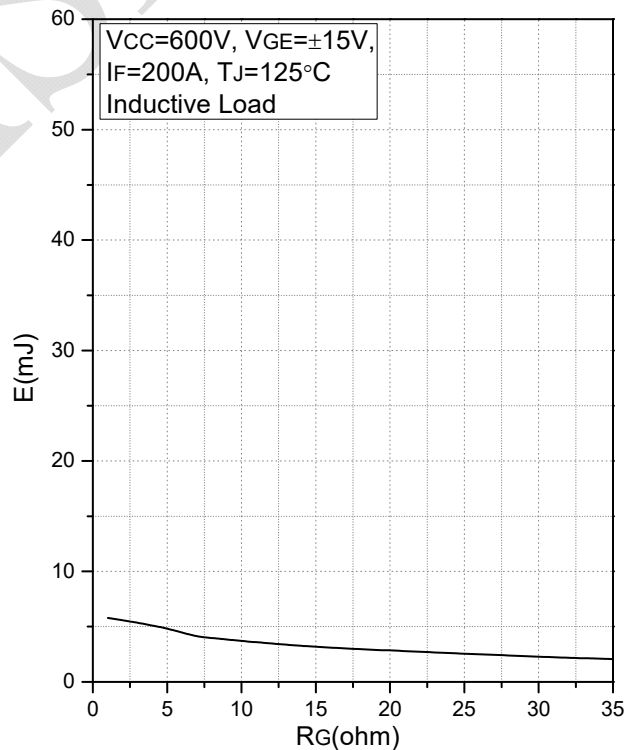

Fig.8 Typical Switching Loss vs. Gate Resistance (Diode, Chopper)

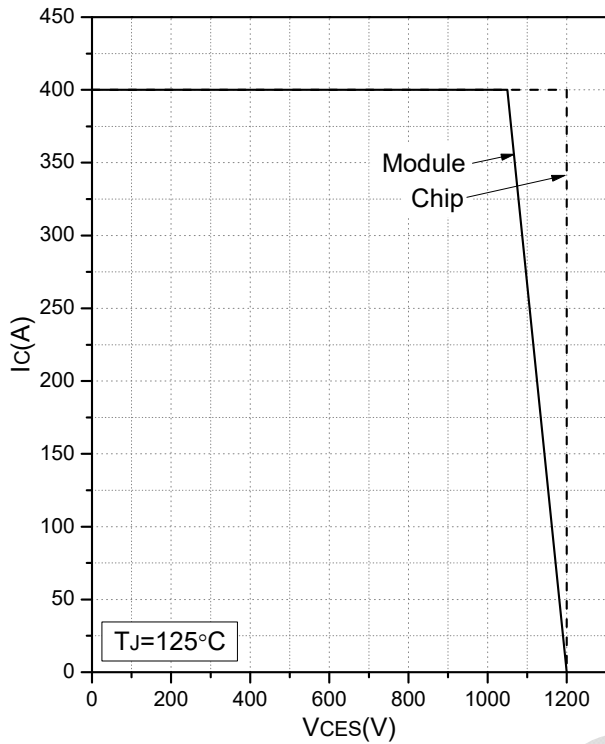

Fig.9 Reverse Bias Safe Operation Area (RBSOA)

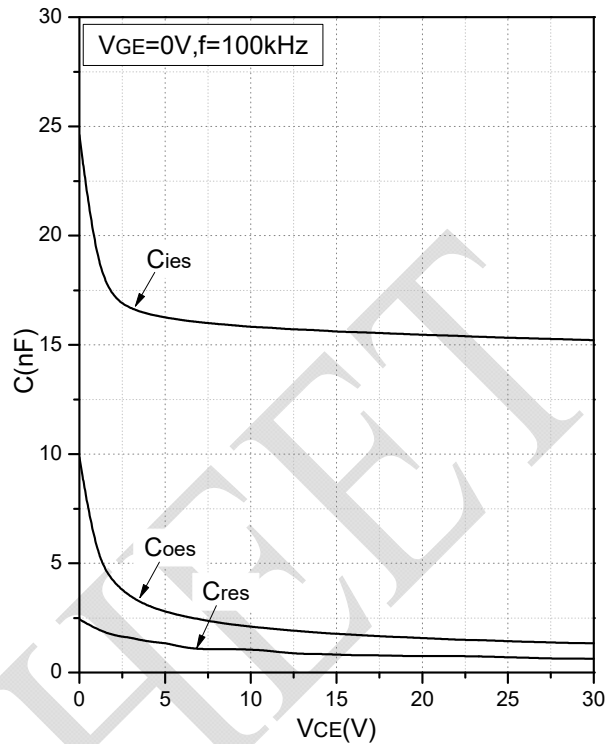

Fig.10 Capacitance Characteristics

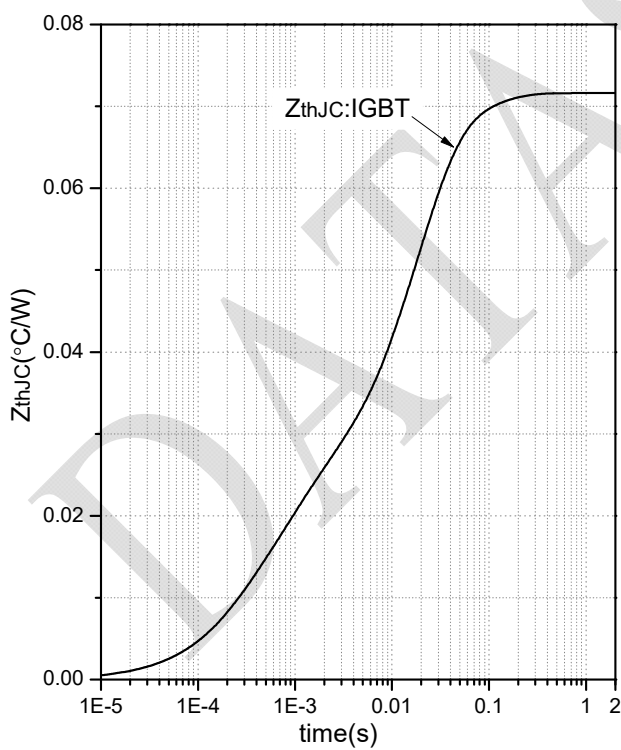

Fig.11 Transient Thermal Impedance (IGBT)

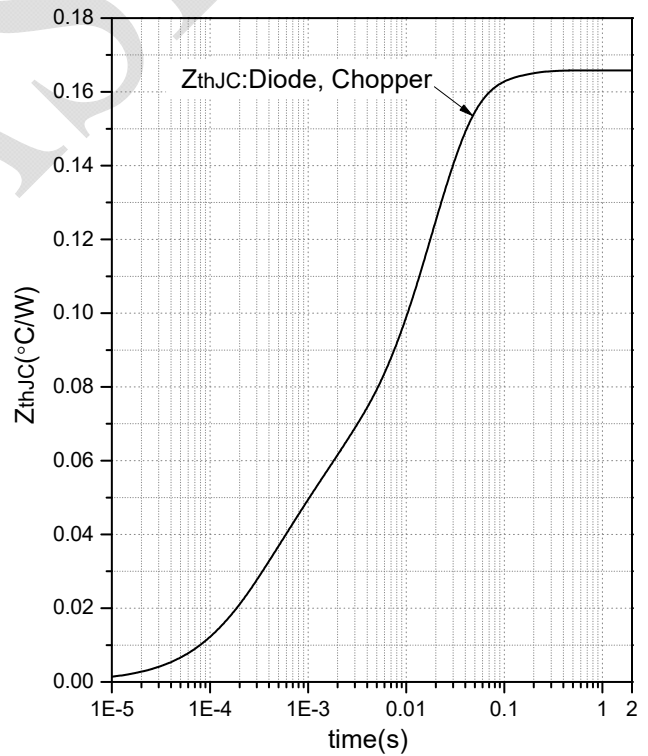

Fig.12 Transient Thermal Impedance (Diode, Chopper)

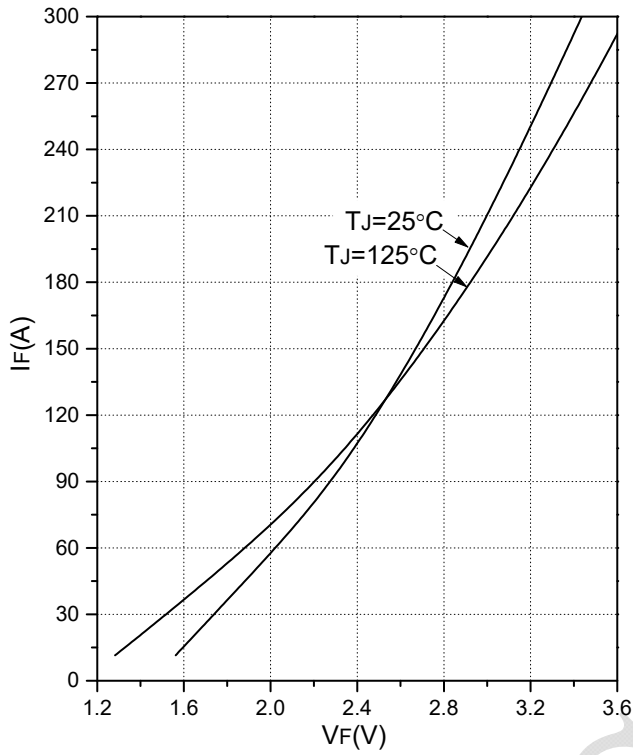

Fig.13 Forward Characteristics of Diode (Diode, Reverse)

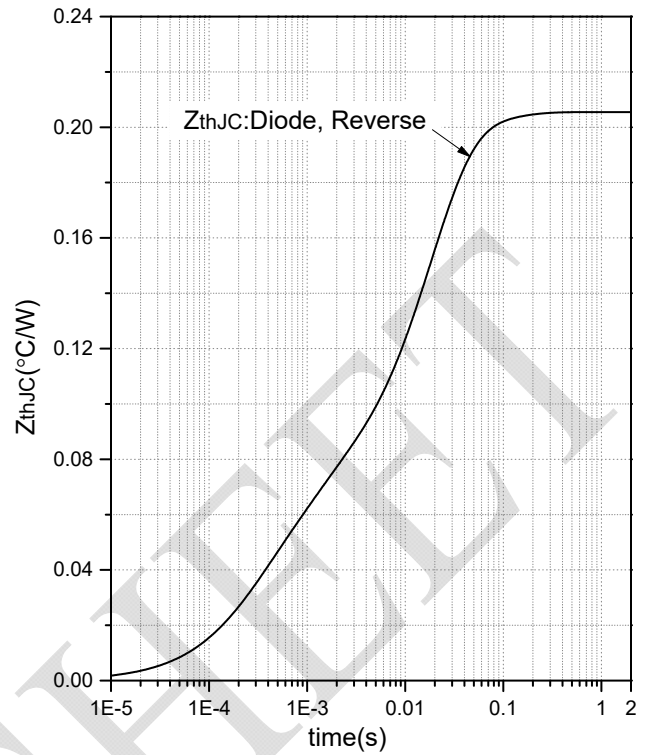
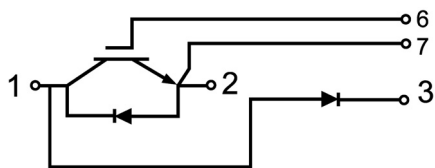

Fig.14 Transient Thermal Impedance (Diode, Reverse)

DATA SHEET



Internal Circuit



CU

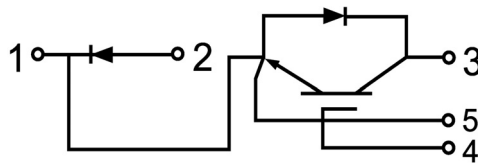

CL

Package Outline (Unit: mm):

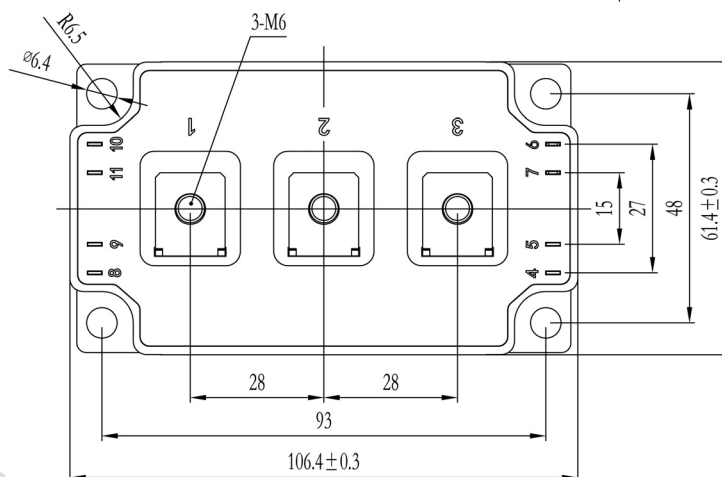
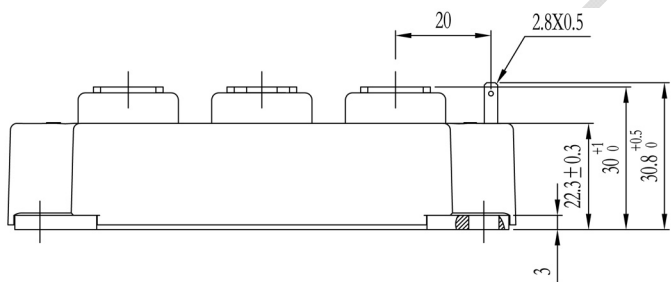

CU

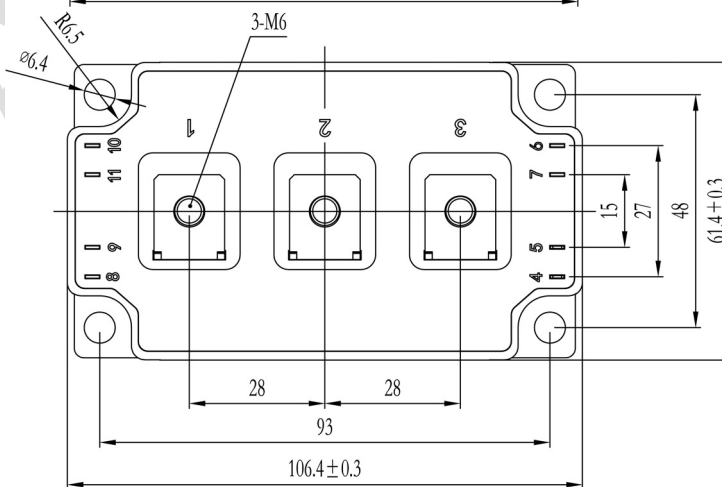

CL



Date	Revision	Notes
02/18/2022	A	Final Version

Announcements

Information in this document is believed to be accurate and reliable. However, NJSME does not give any representations or warranties, expressed or implied, as to the accuracy or completeness of such information and shall have no liability for the consequences of use of such information.

Right to Make Changes

NJSME reserves the right to make changes to information published in this document, including without limitation specifications and product descriptions, at any time and without notice. This document supersedes and replaces all information supplied prior to the publication hereof.

The datasheet with “REV.” + “Arabic numerals” is based on engineering data for initial reference purpose only.

The released datasheet would be issued with “REV.” + “alphabet characters”.

DATA SHEET