



# GT15FF120C6H

## IGBT Module

Preliminary Data

### Features:

- Field Stop Trench Gate IGBT
- Short Circuit Rated >10 $\mu$ s
- Low Saturation Voltage
- Low Switching Loss
- 100% RBSOA Tested(2 $\times$ I<sub>c</sub>)
- Low Stray Inductance
- Lead Free, Compliant with RoHS Requirement

### Circuit Diagram

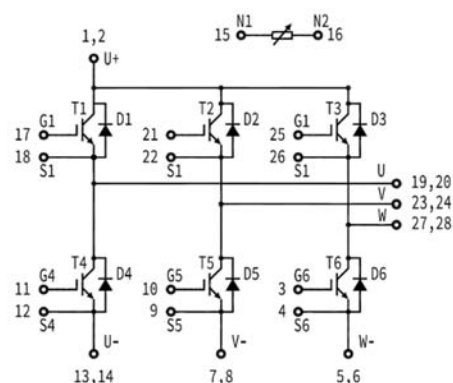

### Applications:

- Industrial Inverters

### IGBT, Inverter

#### Maximum Rated Values (T<sub>C</sub>=25°C unless otherwise specified)

V <sub>CES</sub>	Collector-Emitter Blocking Voltage		1200	V
V <sub>GES</sub>	Gate-Emitter Voltage		±20	V
I <sub>c</sub>	Continuous Collector Current	T <sub>C</sub> =100°C	15	A
		T <sub>C</sub> =25°C	30	A
I <sub>CM</sub>	Repetitive Peak Collector Current	T <sub>J</sub> =175°C	30	A
t <sub>sc</sub>	Short Circuit Withstand Time		>10	μs
P <sub>D</sub>	Maximum Power Dissipation per IGBT	T <sub>C</sub> =25°C, T <sub>Jmax</sub> =175°C	162	W



## Electrical Characteristics of IGBT ( $T_C=25^\circ\text{C}$ unless otherwise specified)

### Static Characteristics

Symbol	Description	Conditions	Min.	Typ.	Max.	Units
$V_{GE(th)}$	Gate-Emitter Threshold Voltage	$I_C=1\text{mA}$ , $V_{CE}=V_{GE}$	5.00	5.90	6.50	V
$V_{CE(sat)}$	Collector-Emitter Saturation Voltage	$I_C=15\text{A}$ , $V_{GE}=15\text{V}$	$T_J=25^\circ\text{C}$	1.85	2.00	V
			$T_J=125^\circ\text{C}$	2.05		V
			$T_J=150^\circ\text{C}$	2.10		V
$I_{CES}$	Collector-Emitter Leakage Current	$V_{GE}=0\text{V}$ , $V_{CE}=V_{CES}$ , $T_J=25^\circ\text{C}$			1	mA
$I_{GES}$	Gate-Emitter Leakage Current	$V_{GE}=\pm 20\text{V}$ , $V_{CE}=0\text{V}$ , $T_J=25^\circ\text{C}$			100	nA
$C_{ies}$	Input Capacitance	$V_{CE}=25\text{V}$ , $V_{GE}=0\text{V}$ , $f=100\text{kHz}$		1.45		nF
$C_{oes}$	Output Capacitance			0.10		nF
$C_{res}$	Reverse Transfer Capacitance			0.06		nF

### Switching Characteristics

$t_{d(on)}$	Turn-on Delay Time	$V_{CC}=600\text{V}$ , $I_C=15\text{A}$ , $R_{Gon}=36\Omega$ , $V_{GE}=\pm 15\text{V}$ , Inductive Load	$T_J=25^\circ\text{C}$		85		ns
			$T_J=125^\circ\text{C}$		89		
			$T_J=150^\circ\text{C}$		92		
$t_r$	Rise Time		$T_J=25^\circ\text{C}$		50		ns
			$T_J=125^\circ\text{C}$		52		
			$T_J=150^\circ\text{C}$		53		
$t_{d(off)}$	Turn-off Delay Time		$T_J=25^\circ\text{C}$		137		ns
			$T_J=125^\circ\text{C}$		146		
			$T_J=150^\circ\text{C}$		151		
$t_f$	Fall Time	$T_J=25^\circ\text{C}$		222		ns	
		$T_J=125^\circ\text{C}$		290			
		$T_J=150^\circ\text{C}$		428			
$E_{on}$	Turn-on Switching Loss	$V_{CC}=600\text{V}$ , $I_C=15\text{A}$ , $R_{Gon}=36\Omega$ , $V_{GE}=\pm 15\text{V}$ , $di/dt=232\text{A}/\mu\text{s}$ ( $T_J=150^\circ\text{C}$ ), Inductive Load	$T_J=25^\circ\text{C}$		2.35		mJ
			$T_J=125^\circ\text{C}$		3.03		
			$T_J=150^\circ\text{C}$		3.29		



E <sub>off</sub>	Turn-off Switching Loss	V <sub>CC</sub> =600V, I <sub>C</sub> =15A, R <sub>Goff</sub> =36Ω, V <sub>GE</sub> =±15V, du/dt=1984V/μs(T <sub>J</sub> =150°C), Inductive Load	T <sub>J</sub> =25°C	0.70	mJ
			T <sub>J</sub> =125°C	1.23	
			T <sub>J</sub> =150°C	1.28	
Q <sub>g</sub>	Total Gate Charge	V <sub>GE</sub> =+15V...-15V	T <sub>J</sub> =25°C	354	nC
R <sub>G</sub>	Internal Gate Resistance			0	Ω
RBSOA	I <sub>C</sub> =30A, V <sub>CC</sub> =1050V, V <sub>p</sub> =1200V, R <sub>G</sub> =36Ω, V <sub>GE</sub> =+15V to 0V, T <sub>J</sub> =150°C			Trapezoid	
SCSOA	V <sub>CC</sub> =600V, V <sub>GE</sub> =±15V, R <sub>Gon</sub> =36Ω, R <sub>Goff</sub> =36Ω, T <sub>J</sub> =125°C			10	μs
R <sub>θJC</sub>	Thermal Resistance: Junction-to-Case (per IGBT)			0.928	°C/W

## Diode, Inverter

### Maximum Rated Values (T<sub>C</sub>=25°C unless otherwise specified)

V <sub>RRM</sub>	Repetitive Peak Reverse Voltage	1200	V
I <sub>F</sub>	Diode Continuous Forward Current	15	A
I <sub>FM</sub>	Diode Maximum Forward Current	30	A

### Electrical Characteristics of Diode (T<sub>C</sub>=25°C unless otherwise specified)

Symbol	Description	Conditions	Min.	Typ.	Max.	Units
V <sub>FM</sub>	Forward Voltage	I <sub>F</sub> =15A	T <sub>J</sub> =25°C	1.90		V
			T <sub>J</sub> =125°C	2.05		
			T <sub>J</sub> =150°C	2.00		
t <sub>rr</sub>	Reverse Recovery Time		T <sub>J</sub> =25°C	154		ns
			T <sub>J</sub> =125°C	159		
			T <sub>J</sub> =150°C	206		
I <sub>rr</sub>	Peak Reverse Recovery Current	I <sub>F</sub> =15A, -diF/dt=344A/μs(T <sub>J</sub> =150°C), V <sub>rr</sub> =600V, V <sub>GE</sub> =-15V	T <sub>J</sub> =25°C	7.8		A
			T <sub>J</sub> =125°C	12.2		
			T <sub>J</sub> =150°C	12.8		
Q <sub>rr</sub>	Reverse Recovery Charge		T <sub>J</sub> =25°C	0.83		μC
			T <sub>J</sub> =125°C	1.22		
			T <sub>J</sub> =150°C	1.47		



E <sub>rec</sub>	Reverse Recovery Energy	I <sub>F</sub> =15A, -diF/dt=344A/μs(T <sub>J</sub> =150°C), V <sub>rr</sub> =600V, V <sub>GE</sub> =-15V	T <sub>J</sub> =25°C	0.10	mJ
			T <sub>J</sub> =125°C	0.15	
			T <sub>J</sub> =150°C	0.17	
R <sub>θJC</sub>	Thermal Resistance: Junction-To-Case (per Diode)			1.377	°C/W

### Internal NTC-Thermistor Characteristics

R <sub>25</sub>	T <sub>C</sub> =25°C	22.7		kΩ
ΔR/R	T <sub>C</sub> =100°C, R <sub>100</sub> =1481Ω		±3	%
P <sub>25</sub>	T <sub>C</sub> =25°C	5		mW
B <sub>25/50</sub>	R <sub>2</sub> =R <sub>25</sub> exp[B <sub>25/50</sub> (1/T <sub>2</sub> -1/(298.15K))]	3950		K
B <sub>25/80</sub>	R <sub>2</sub> =R <sub>25</sub> exp[B <sub>25/80</sub> (1/T <sub>2</sub> -1/(298.15K))]	4000		K

### Module

Symbol	Description		Min.	Typ.	Max.	Units
V <sub>iso</sub>	Isolation Voltage (All Terminals Shorted)	RMS, f=50Hz, 30s	4500			V
T <sub>J</sub>	Maximum Junction Temperature				175	°C
T <sub>JOP</sub>	Maximum Operating Junction Temperature Range		-40		+150	°C
T <sub>stg</sub>	Storage Temperature		-40		+125	°C
CTI	Comparative Tracking Index		200			
R <sub>θCS</sub>	Case-To-Sink Thermally (Conductive Grease Applied)				0.07	°C/W
T	Mounting Screw:M4		1.0		1.5	N·m
G	Weight			39		g



## Ordering Information Table

Device code

G	T	15	FF	120	C6	H
①	②	③	④	⑤	⑥	⑦

- ① - IGBT Module
- ② - Trench, Low Switching Losses IGBT
- ③ - Rated Current (15=15A)
- ④ - Circuit Configuration (Full Bridge)
- ⑤ - Rated Voltage (120=1200V)
- ⑥ - Package Type
- ⑦ - Test Level (Pass the Important Reliability Test-Industrial Grade)

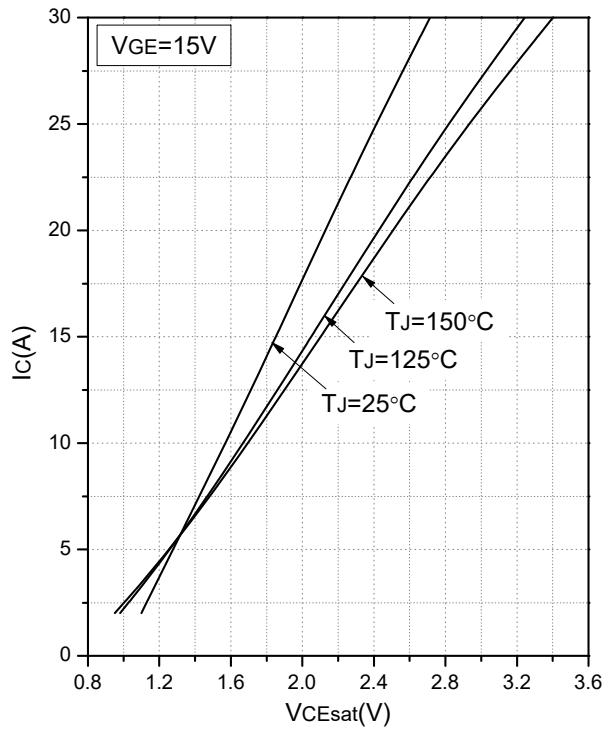

Fig.1 Typical Saturation Voltage Characteristics (Inverter)

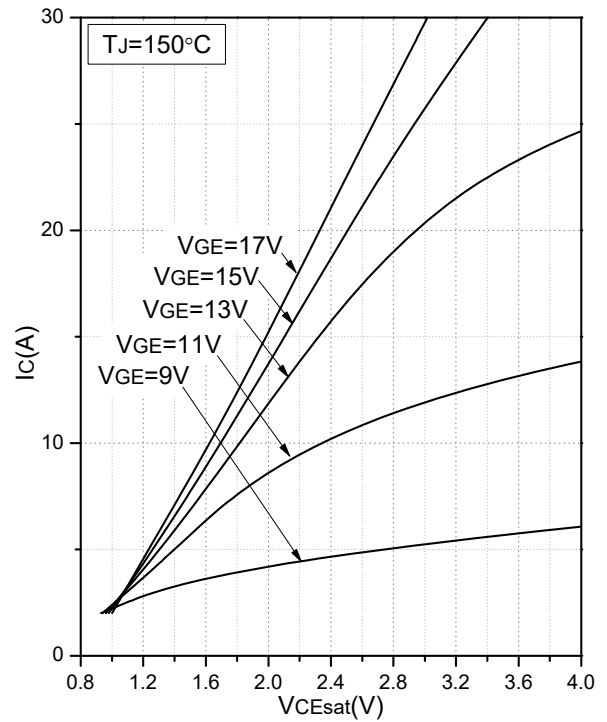

Fig.2 Typical Output Characteristics (Inverter)

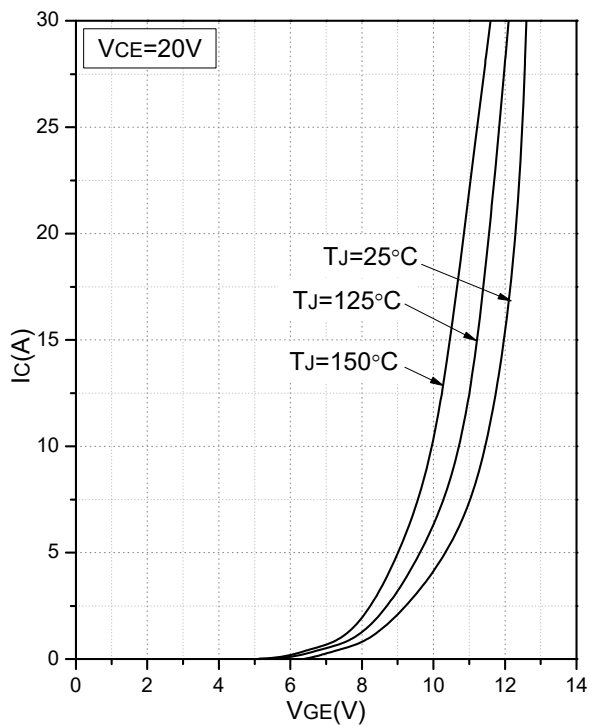

Fig.3 Transfer Characteristic (Inverter)

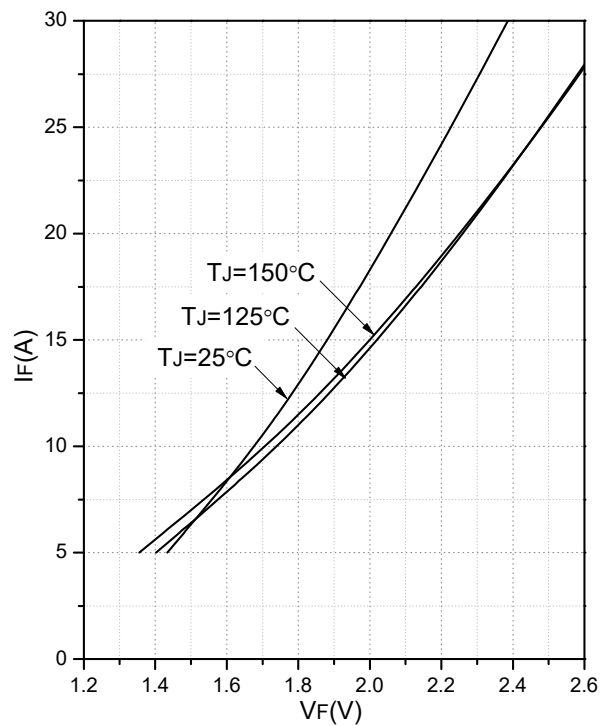

Fig.4 Forward Characteristics of Diode (Inverter)

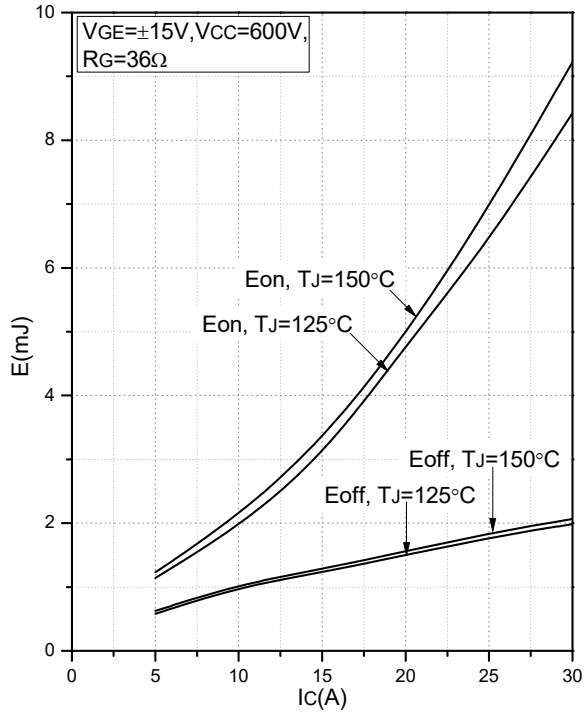

Fig.5 Typical Switching Loss vs. Collector Current (Inverter)

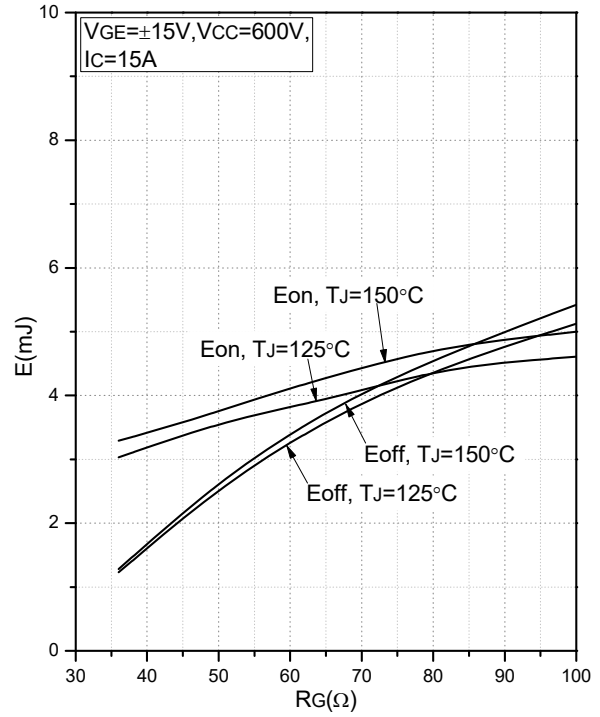

Fig.6 Typical Switching Loss vs. Forward Current (Inverter)

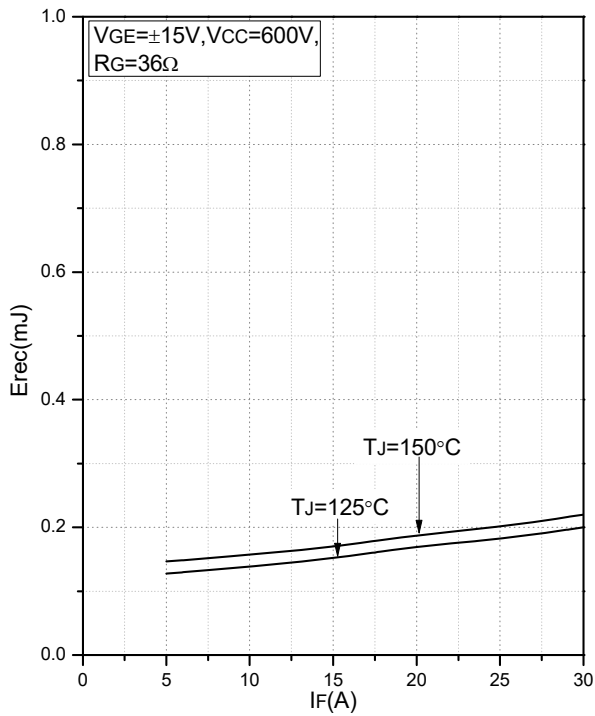

Fig.7 Typical Switching Loss vs. Gate Resistance (Inverter)

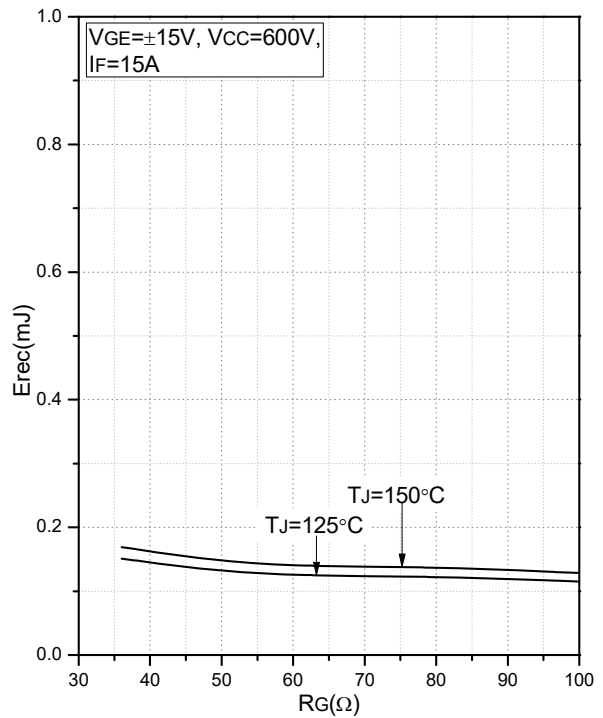

Fig.8 Typical Switching Loss vs. Gate Resistance (Inverter)

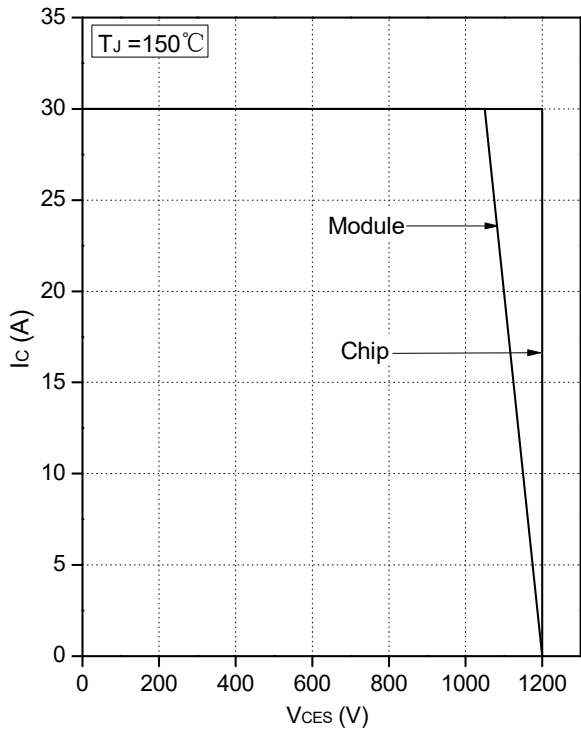

Fig.9 Reverse Bias Safe Operation Area (RBSOA)

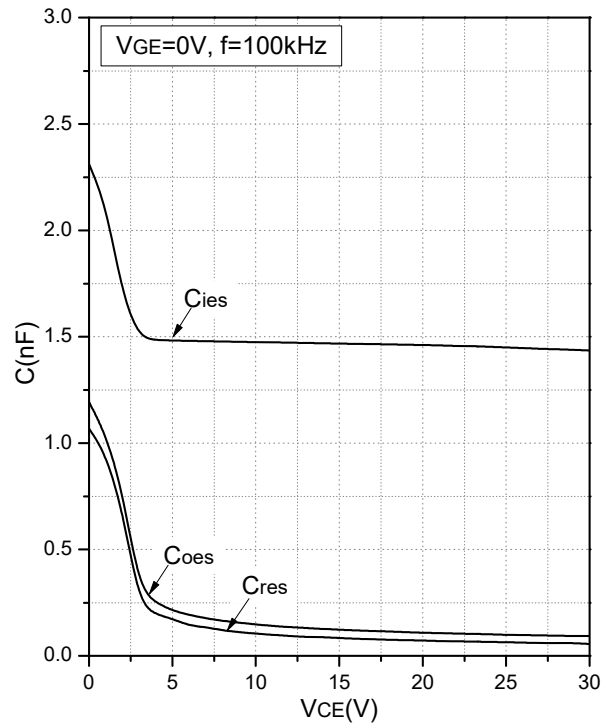

Fig.10 Capacitance Characteristics

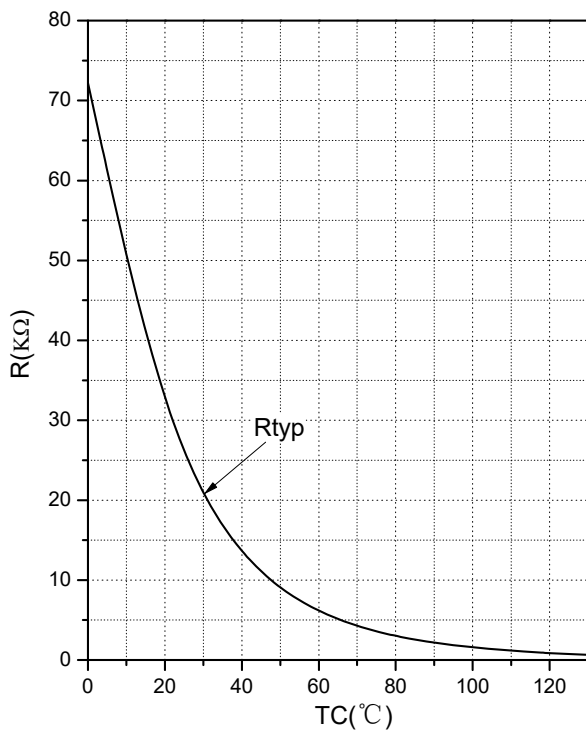

Fig.11 NTC Temperature Characteristics

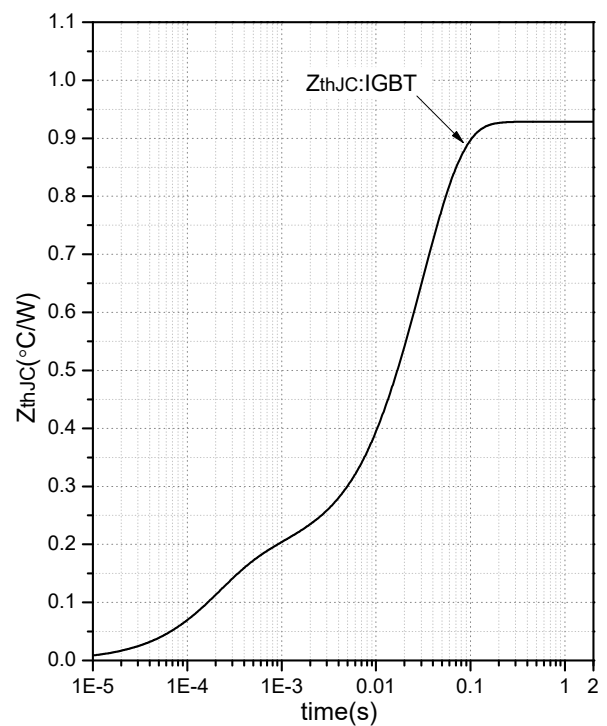

Fig.12 Transient Thermal Impedance (IGBT)



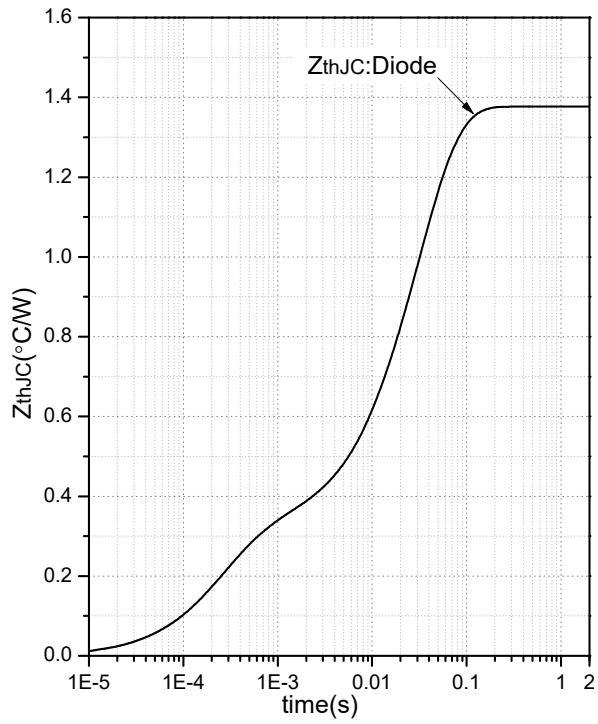
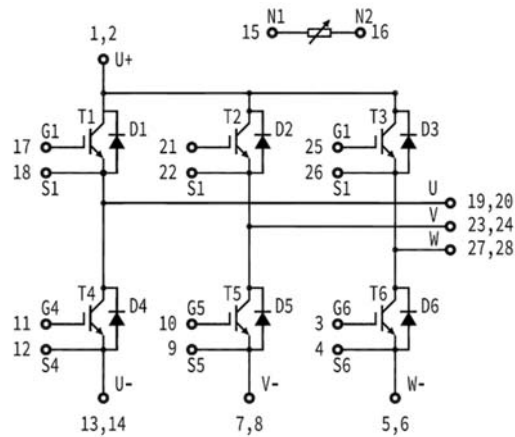

Fig.13 Transient Thermal Impedance (Diode)



## Internal Circuit



## Package Outline (Unit: mm):

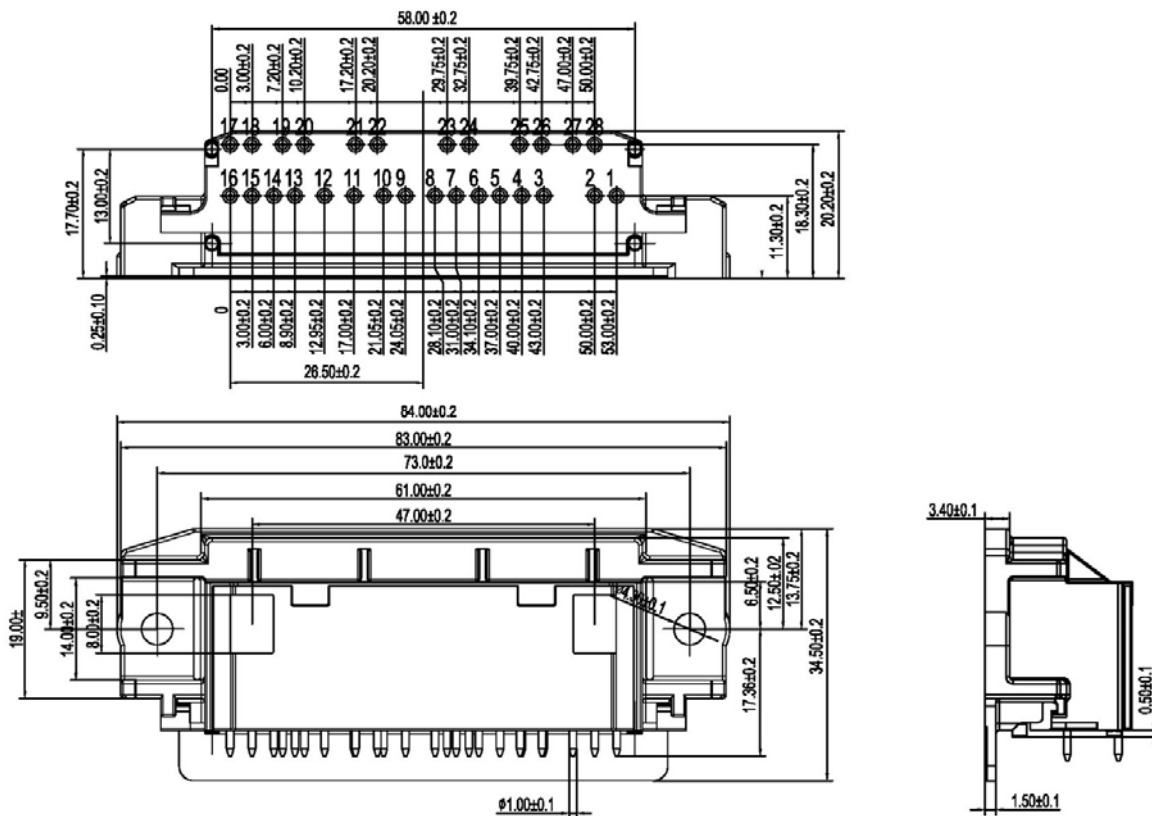



Date	Revision	Notes
10/23/2023	01	Initial Release

## Announcement

Information in this document is believed to be accurate and reliable. However, NJSME does not give any representations or warranties, expressed or implied, as to the accuracy or completeness of such information and shall have no liability for the consequences of use of such information.

## Right to Make Changes

NJSME reserves the right to make changes to information published in this document, including without limitation specifications and product descriptions, at any time and without notice. This document supersedes and replaces all information supplied prior to the publication hereof.

The datasheet with “REV.” + “Arabic numerals” is based on engineering data for initial reference purpose only.

The released datasheet would be issued with “REV.” + “alphabet characters”.