

for Automotive Electronics

SPECIFICATIONS

Customer	
Product Name	Automotive Molded SMD Power Inductor
Sunlord Part Number	AMP1006H Series
Customer Part Number	
Weight/MPQ	3.84g/pcs Typ., 500pcs/reel

New Released, Revised

SPEC No.: AMP0313220000

【This SPEC is total 13 pages.】

【ROHS Compliant Parts】

Approved By	Checked By	Issued By

Shenzhen Sunlord Electronics Co., Ltd.

Address: Sunlord Industrial Park, Dafuyuan Industrial Zone, Guanlan, Shenzhen, China 518110

Tel: +86-755-29832333 Fax: +86-755-82269029 E-Mail: sunlord@sunlordinc.com

【For Customer approval Only】 Date:

Qualification Status: Full Restricted Rejected

Approved By	Verified By	Re-checked By	Checked By

Comments:

Version Change History							
Rev.	Date	Item	Changed Contents	Change Reasons	Drawing	Check	Approval
01	/	/	/	New release	Yixin Wang	Yubo Su	Yubo Su

for Automotive Electronics

〈Content〉

No.	Item	Page
1	Scope	4
2	Product Description and Identification (Part Number)	4
3	Shape and Dimensions	4
4	Electrical Characteristics	5
5	Test and Measurement Procedures	6
6	Structure and material list	6
7	Product Marking	7
8	Reliability Test	7~8
9	Packaging and Storage	9~11
10	Visual inspection standard of product	12
11	Recommended Soldering Technologies	13
12	Precautions	13

for Automotive Electronics

1 Scope

1.1 Scope of parts

This specification applies to the AMP1006H Series of Automotive Molded SMD power inductor based on AEC-Q200.

1.2 Scope of application

Product numbers recorded in this specification are used for automotive applications.

1.3 Operating and storage temperature

The part temperature (ambient + temp. rise) should not exceed 150 °C under worst case operating conditions. Circuit design, component placement, PCB trace size and thickness, airflow and other cooling provisions all affect the part temperature. Part temperature should be verified in the end application.

- 1) Operating and storage temperature range (individual chip without packing): -55°C ~ +150°C (including self-heating).
- 2) Storage temperature range (packaging conditions): -10°C~+40°C and RH 70% (Max.).

1.4 MSL: level1.

2 Product Description and Identification (Part Number)

1) Description:

AMP1006H series of Automotive Molded SMD power inductor.

2) Product Identification (Part Number)

AMP	1006	H	3R3	M	T	□□□
①	②	③	④	⑤	⑥	⑦

① Product Type	AMP: Automotive Molded SMD Power Inductor
② External Dimensions(LxWxH) [mm]	1006: 10.8×10.0×6.3mm
③ Feature type	H: H type material
④ Nominal Inductance	3R3: 3.3μH, 4R7: 4.7μH, 6R8: 6.8μH, 100: 10.0μH
⑤ Inductance Tolerance	M: ±20%
⑥ Packing	T: tape & Reel
⑦ Special Process code	Standard product is blank

3 Shape and Dimensions

Dimensions and recommended PCB pattern for reflow soldering, please see Fig.3-1, Fig. 3-2 and Table 3-1.

Fig.3-1

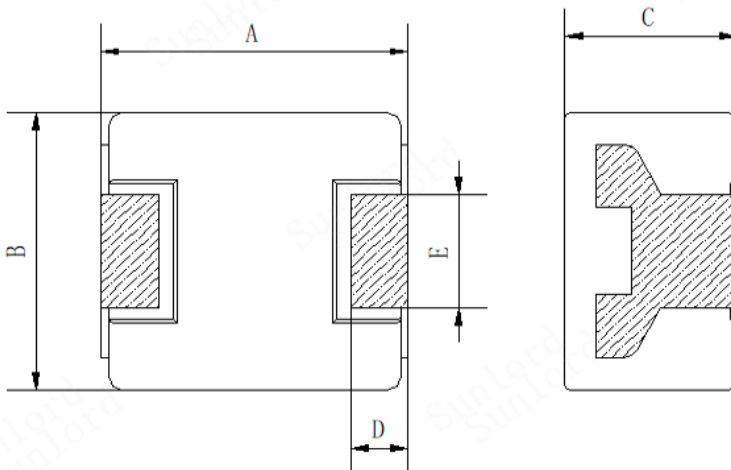
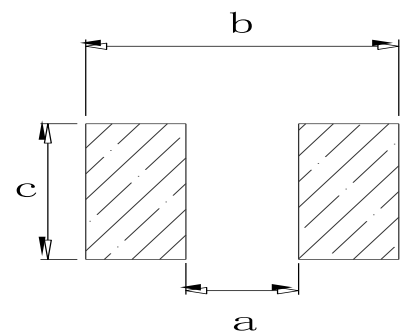

Fig.3-2



Recommend Land Pattern

[Table 3-1] (Unit: mm)

Series	A	B	C	D	E	a	b	c
AMP1006H	11.0±0.5	10.0±0.3	6.3±0.2	2.2±0.5	4.5±0.3	5.8ref.	12.0ref.	5.0ref.

4 Electrical Characteristics

Part Number	Inductance	DC Resistance		Saturation Current		Heat Rating Current	Withstanding Voltage	Marking
	100KHz/1V	Max.	Typ.	Max	Typ.	Typ.	Typ.	
Units	μH	$\text{m}\Omega$		A		A	V_{DC}	
Symbol	L	DCR		Isat		I _{rms}	/	
AMP1006H1R5MT	1.5±20%	3.9	3.3	20	26	19.5	100	1R5
AMP1006H4R7MT	4.7±20%	9.0	7.5	15	20	15		4R7
AMP1006H6R8MT	6.8±20%	13	10.5	14	18	11		6R8
AMP1006H150MT	15±20%	37	31	8.5	10.5	6.5		150
AMP1006H220MT	22±20%	49	41.0	6.5	8.2	5.5		220

Note: ※1 : Rated current: Isat (Max.) or I_{rms}(Typ.), whichever is smaller;
 ※2 : Saturation Current: Typ. Value, DC current at which the inductance drops approximately 30% from its value without current;
 ※3 : Heat Rating Current: DC current that causes an approximate ΔT of 40°C from 20°C ambient.

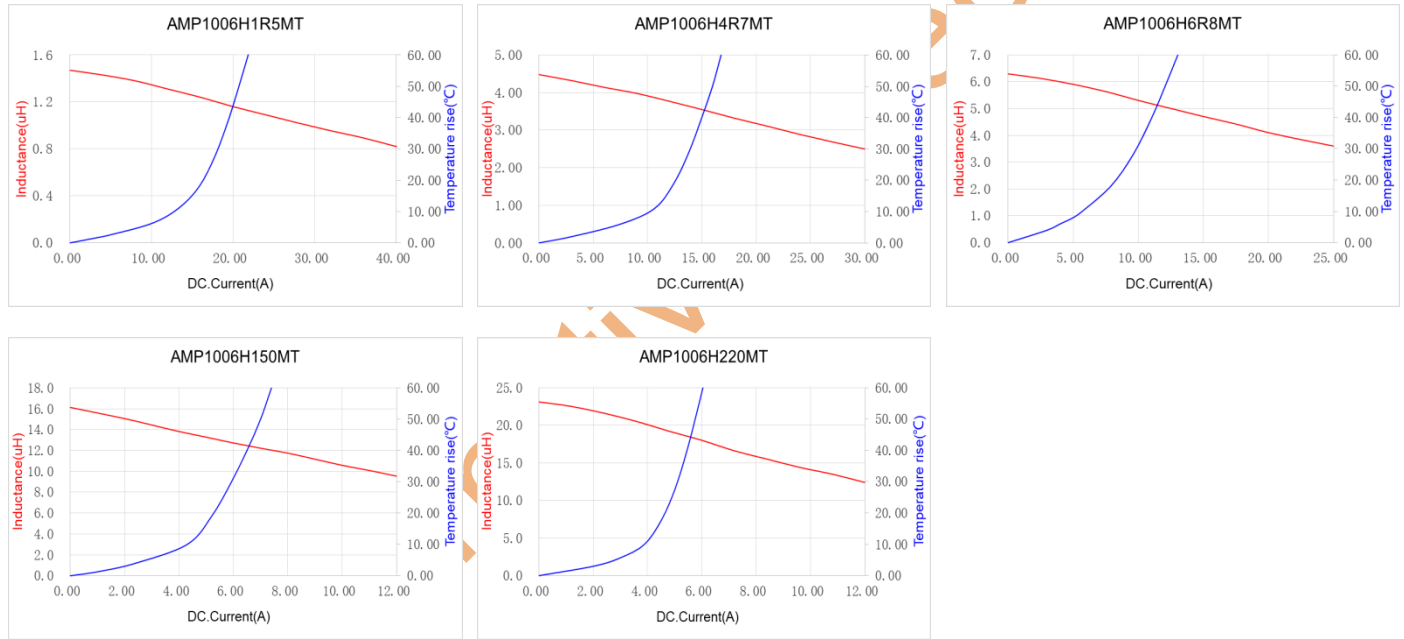

for Audit

5 Test and Measurement Procedures

5.1 Test Conditions

5.1.1 Unless otherwise specified, the standard atmospheric conditions for measurement/test as:

- a. Ambient Temperature: $20 \pm 15^{\circ}\text{C}$.
- b. Relative Humidity: $65 \pm 20\%$.
- c. Air Pressure: 86kPa to 106kPa.

5.1.2 If any doubt on the results, measurements/tests should be made within the following limits:

- a. Ambient Temperature: $20 \pm 2^{\circ}\text{C}$.
- b. Relative Humidity: $65 \pm 5\%$.
- c. Air Pressure: 86kPa to 106kPa.

5.2 Visual Examination

Inspection Equipment: visual.

5.3 Electrical Test

5.3.1 Inductance (L)

- a. Refer to **Item 4**. Test equipment: WK3260B LCR meter or equivalent.
- b. Test Frequency and Voltage: refers to **Item 4**.

5.3.2 Direct Current Resistance (DCR)

- a. Refer to **Item 4**.
- b. Test equipment: HIOKI 3540 or equivalent.

5.3.3 Saturation Current (Isat)

- a. Refer to **Item 4**.
- b. Test equipment: WK3260B LCR meter or equivalent.

5.3.4 Temperature rise current (Irms)

- a. Refer to **Item 4**.
- b. Test equipment (see Fig. 5.3.4-1, Fig.5.3.4-2): Electric Power, Electric current meter, Thermometer.
- c. Measurement method:
 1. Set test current to be 0 mA.
 2. Measure initial temperature of choke surface.
 3. Gradually increase current and measure choke temperature for corresponding current.
 4. Definition of Temperature rise current: DC current that causes the temperature rise (ΔT) from ambient temperature.

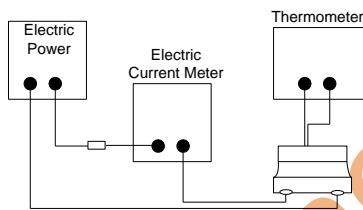

Fig. 5.3.4-1

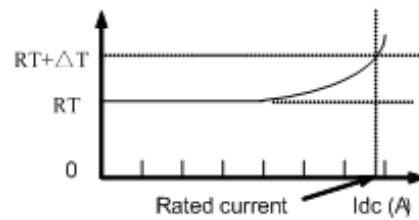

Fig. 5.3.4-2

6 Structure and material list

The structure and material list of AMP1006H products please refer to Fig.6-1 and Table 6-1.

Fig.6-1

[Table. 6-1]

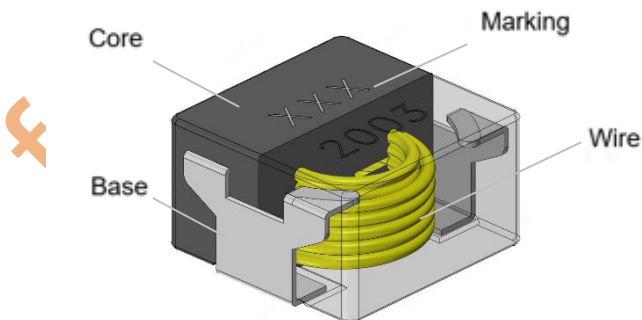

Components	Material
Marking	/
Core	Alloy Sponge Powder
Wire	Polyurethane copper wire
Base	Copper plated with Sn

7 Product Marking

The product marking, please refer to Fig.7-1.

XXX: Inductance, refer to specifications

2003: trace code



Fig.7-1

8 Reliability Test

No.	Test Items	Test Methods	Requirements
1	Visual	Inspect the appearance at least 10X.	No visible mechanical damage
2	Physical Dimension	length, width, thickness of the components.	meet the specifications
3	Pre-and Post -Stress Electrical Test	Inductance of the components DC resistance of the components	(1)The electrical values before the test meet the specifications (2)The electrical values after the test meet the rate of change requirements; Inductance change:Within $\pm 20\%$
4	Terminal strength	①Precondition: 3 reflow cycles; ②Test condition:17.7N,X,Ydirect, 60(+5)s,Speed:1.0mm/s.	No removal or split of the termination or other defects shall occur
5	Board Flex	①Precondition: 3 reflow cycles; ②Test condition: 2mm,60(+5)s.	No visible mechanical damage
6	Solder ability	Method 1: ①pretreatment:155°C,4h ; ②245°C,5(-0.5,+0)s ,25 \pm 6 mm/s; ③Solder:Sn/3.0Ag/0.5Cu.	Wetting shall be exceeded 95% coverage
		Method 2: ①Steam aging:8h \pm 15min; ②245°C,5(-0.5,+0)s,25 \pm 6 mm/s; ③Solder:Sn/3.0Ag/0.5Cu.	
		Method 3: ①Steam aging:8h \pm 15min; ②260°C,30 \pm 5s ,25 \pm 6 mm/s; ③Solder:Sn/3.0Ag/0.5Cu.	No more than 5% of the solderable termination exhibits exposed underlying, nonwetttable base metal or metallization layers or portions of the ceramic substrate after exposure to molten solder
7	Resistance to Soldering Heat	Method 1: Max 260°C/10s, 3 times.Solder:Sn/3.0Ag/0.5Cu. Note: Reflow Profile refer to reflow profile 1	(1)No visible mechanical damage (2) Inductance change: Within $\pm 20\%$
8	High Frequency Vibration	Reflow 3 times,10~2000Hz,5g,20min/Cycle,4 hours in each 3 mutually perpendicular directions (total of 12 hours) .	(3) DCR: Satisfy electrical characteristic.

9	Mechanical Shock	Reflow 3 times, Half sine shock pulse, 100g, 6ms, 6 shocks in each 3 mutually perpendicular directions (total of 18 shocks).	
10	Temperature Cycling	Reflow 3 times, ambient temperature -55°C/(30min), ambient temperature +150°C/(30min), transforming interval: 20s, 1000 cycles.	
11	Low Temperature Exposure (Storage)	① Precondition: 3 reflow cycles; ② Test condition: ambient temperature -55±2°C, 1000(+24) hours.	
12	High Temperature Exposure (Storage)	① Precondition: 3 reflow cycles; ② Test condition: ambient temperature 150±2°C, 1000(+24) hours.	(1) No visible mechanical damage (2) Inductance change: Within ±20% (3) DCR: Satisfy electrical characteristic.
13	Biased Humidity	Reflow 3 times, ambient temperature 85°C, 85%RH, 1000 hours.	
14	Operational Life	Reflow 3 times, ambient temperature 125±2°C, 1000(+24) hours, rated current.	
15	MSL	Team A: ① Pre- and Post- Stress Electrical and Visual Test ; ② High temperature Bake: 125±5/-0°C, 24 h; ③ Temperature & Humidity Soak: 85°C, 85%RH, 168 h; ④ Ref low: MAX. 260°C/10 s, 3 times.	(1) No visible mechanical damage (2) Inductance change: Within ±20%
16	Flammability	Refer to MIL-STD-202 Method 111、UL-94	① t1 or t2: ≤10s; ② t1 plus t2 for the 5 specimens: ≤50s; ③ t2+t3 for each specimen: ≤30s; ④ No after-flame or after-glow of any specimen up to the holding clamp; ⑤ No cotton indicator ignited by flaming particles or drops.
17	ESD Test	HBM ESD discharge waveform, each 1 time of +/- polarity. Voltage refer to 4KV; Inductance ≥22uh; 8KV; Inductance <22uh;	(1) No visible mechanical damage (2) Inductance change: Within ±20% (3) DCR: Satisfy electrical characteristic.
18	Electrical characteristics	ambient temperature 25°C(15+3min) → ambient temperature -55°C(15+3min) → ambient temperature +150°C(15+3min).	Inductance change should be within ±20% of reference value measuring at 25°C
19	solvent resistance test	Add Aqueous wash chemical. OKEM Clean or equivalent. Do not use banned solvents.	① No specified markings which are missing in whole or in part, faded, smeared, blurred, or shifted (dislodged) to the extent ; ② No specimen shall have cracks, separations, crazing, swelling, softening, and degradation of body material, end caps and seals if present.

9 Packaging and Storage

9.1 Tape and Reel Packaging Dimensions

9.1.1 Taping Dimensions (Unit: mm)

Please refer to Fig. 9.1.1 and Table 9.1.1.

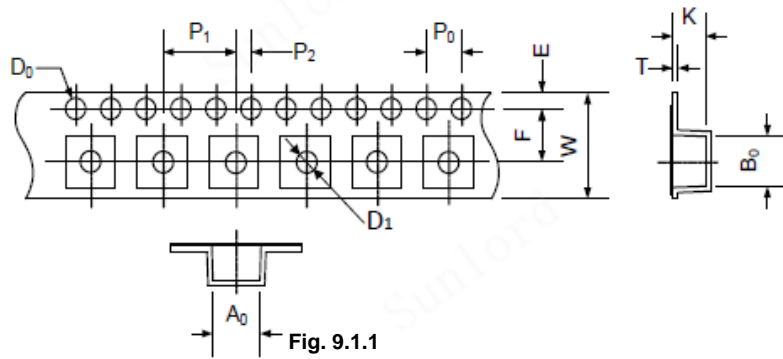

[Table 9.1.1] Unit: mm

Series	A ₀	B ₀	W	E	F	P ₀	P ₁
AMP1006H	10.4±0.1	11.6±0.1	24±0.3	1.75±0.1	11.5±0.1	4.0±0.1	16.0±0.1
Series	P ₂	D ₀	T	K	D ₁	/	/
AMP1006H	2.0±0.1	1.5±0.1	0.45±0.05	7.0±0.1	1.5±0.1	/	/

9.1.2 Direction of rolling

Please refer to Fig. 9.1.2

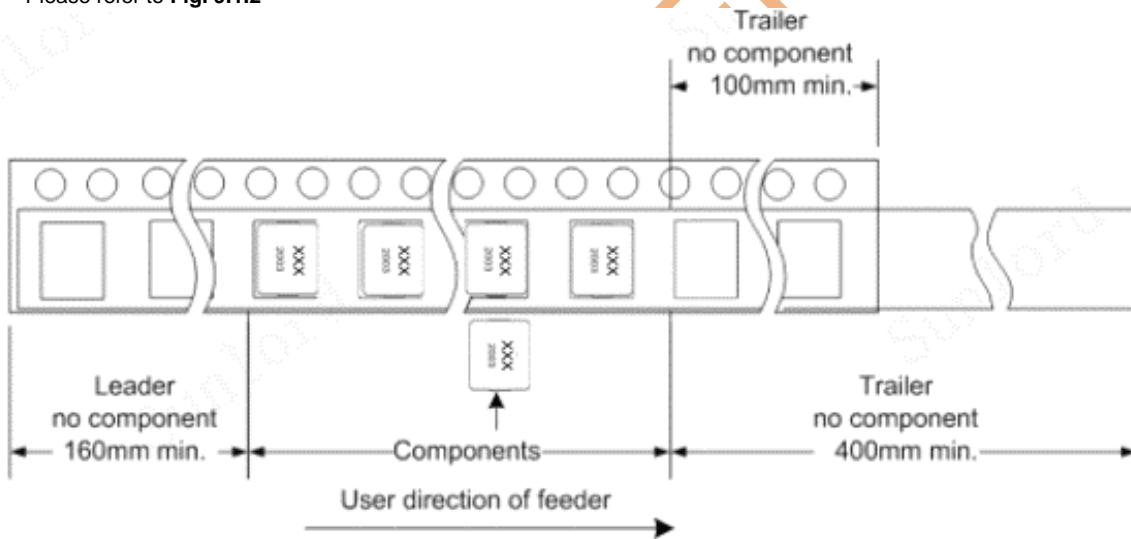

Fig. 9.1.2

9.1.3 Reel Dimensions (Unit: mm)

Please refer to Fig. 9.1.3.

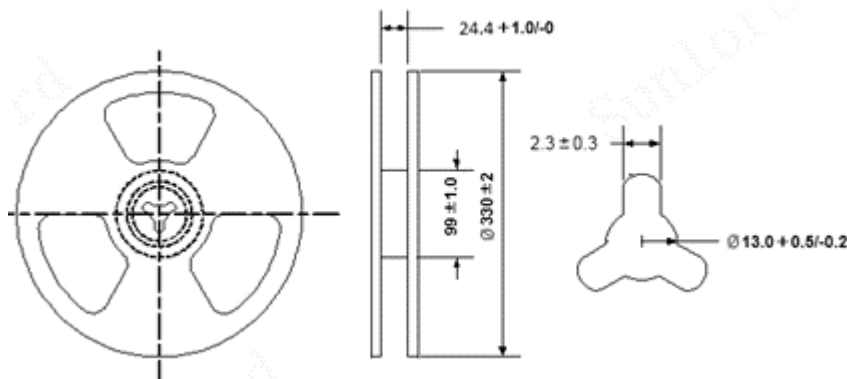

Fig. 9.1.3

- 9.1.4 Top tape strength
Peel-off strength: 10~130gf.
Peel-off angle: 165°~180°, refers to Fig. 9.1.4.
Peel-off speed: 300mm/min.

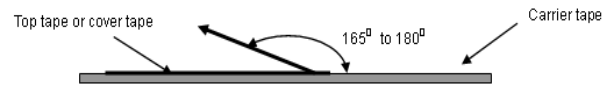

Fig. 9.1.4

- 9.1.5 The number of components
A tape & reel package contains 500 inductors.
- 9.1.6 The allowable number of empty chip cavities: 0 chip.

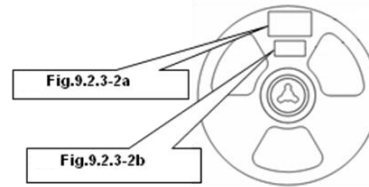

Fig.9.2.3-1

9.2 Packing Documents and Marking

9.2.1 Packing Documents

Packing documents include the following:

- 1) Packaging list
- 2) Certificate of compliance (COC)

9.2.2 Packing QTY.

- 1) Inner Box: 1 reel in each box.
- 2) Outer Box: 5 inner boxes in each outer case.
- 3) 5 reels in each outer case.

[Table 9.2.3-1]

Packaging type	A(mm)	B(mm)	C(mm)
Inner box	340	40	340

9.2.3 Marking

1) Marking label information on reels includes (see Fig.9.2.3-1~2):

Fig.9.2.3-2a: Shipping labels

- a). P/O No.
- b). Customer Part No.
- c). Sunlord Part No.
- d). Quantity.
- e). Lot No.
- f). Date code
- g). Inspection stamp
- h). MFG address as 'Made In China'.

Fig.9.2.3-2b: Production label

- a). P/O No.
- b). Quantity..
- c). Lot No.
- d). Inspe No
- e). Inspection stamp
- f). MFG address as 'Made In China'.
- g). sequence number

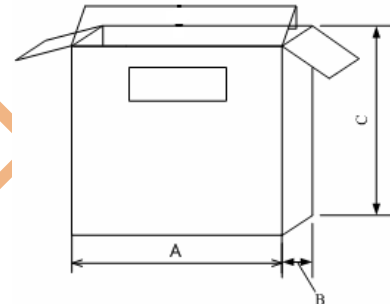

Fig.9.2.3-3

[Table 9.2.3-2]

Packaging type	L(mm)	W(mm)	H(mm)
TYP1	358	358	250

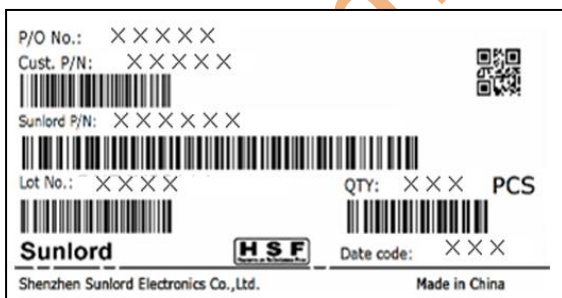

Fig.9.2.3-2a

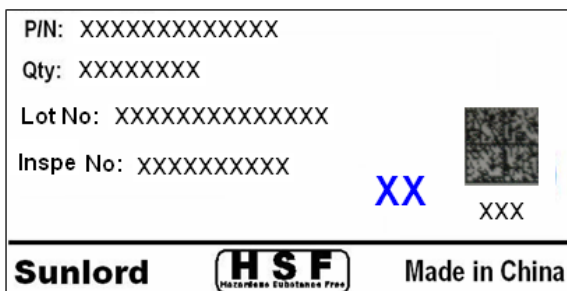

Fig.9.2.3-2b

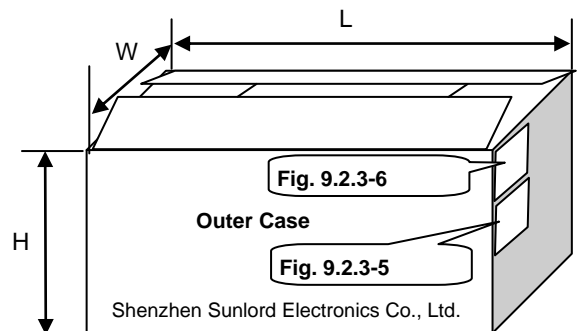

Fig. 9.2.3-4

2) Marking label information on inner box

- a). Inner box please refers to Fig.9.2.3-3 and Table 9.2.3-1.

- b). Marking Label on inner box
 N/A.

3) Marking on outer case (see Fig.9.2.3-4~6):

Out case size please refers to Table 9.2.3-2.

- a). Manufacturer: Sunlord ID:
 "Shenzhen Sunlord Electronics Co., Ltd."
- b). Packing label include the following:
 - i) Customer
 - ii) Manufacturer
 - iii) Date code
 - iv) C/No.

Example; "1/10" means that this case is the 1st of total 10 cases

- v) P/O No.
- vi) Customer Part No.
- vii) Sunlord Part No.
- viii) Quantity.
- ix) Inspection Stamp.

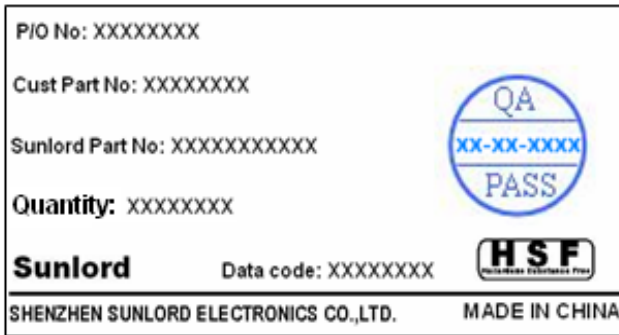

Fig.9.2.3-5

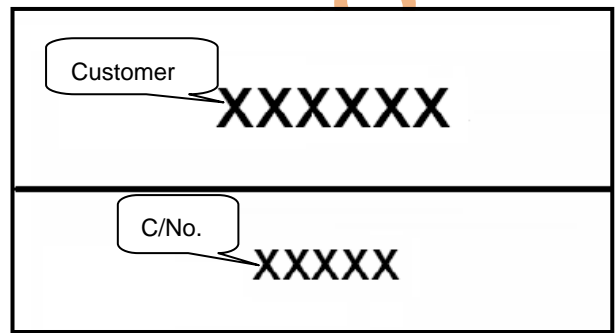
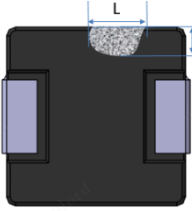
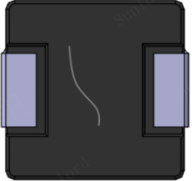
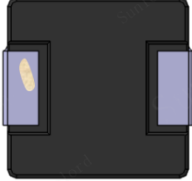



Fig.9.2.3-6

for Automotive

onics

10 Visual inspection standard of product

File No:		Applied to Automotive Molded SMD Power Inductor		REV:01
Effective date:				
No.	Defect Item	Graphic	Rejection identification	Acceptance
1	Core defect		The defect length and width (L and W) more than 2mm, NG.	AQL=0.065
2	Core crack		Cracks can be seen on the bottom surface by eyes, NG.	AQL=0.065
3	Electrode surface dirt		dirt can be seen on the electrode surface by eyes, NG.	AQL=0.065
4	Marking defect		Cracks can be seen on the surface by eyes, NG.	AQL=0.065

11 Recommended Soldering Technologies**11.1 Re-flowing Profile:**

- △ Preheat condition: 150 ~200°C/60~180sec.
- △ Allowed time above 217°C: 60~150sec.
- △ Allowed time above 255°C: 30sec. ref.
- △ Max temp: 260°C.
- △ Max time at max temp: 5sec.
- Solder paste: Sn/3.0Ag/0.5Cu.
- △ Allowed Reflow time: 3x max:
Please refer to **Fig. 11.1-1**.

[Note: The reflow profile in the above table is only for qualification and is not meant to specify board assembly profiles. Actual board assembly profiles must be based on the customer's specific board design, solder paste and process, and should not exceed the parameters as the Reflow profile shows.]

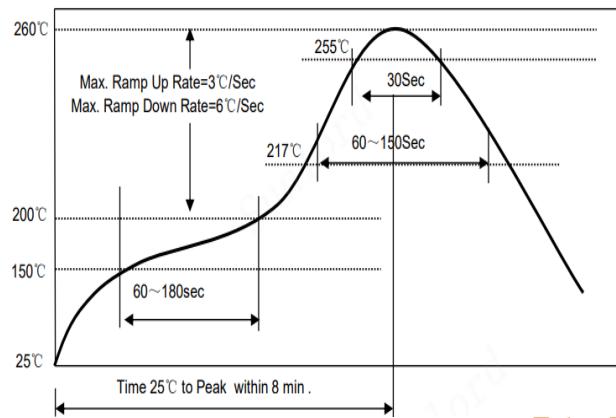

Fig. 11.1-1

11.2 Iron Soldering Profile

- △ Iron soldering power: Max. 30W.
- △ Pre-heating: 150°C/60sec.
- △ Soldering Tip temperature: 350°C Max.
- △ Soldering time: 3sec. Max.
- △ Solder paste: Sn/3.0Ag/0.5Cu.
- △ Max.1 times for iron soldering:
Please refer to **Fig. 11.2-1**.

[Note: Take care not to apply the tip of the soldering iron to the terminal electrodes.]

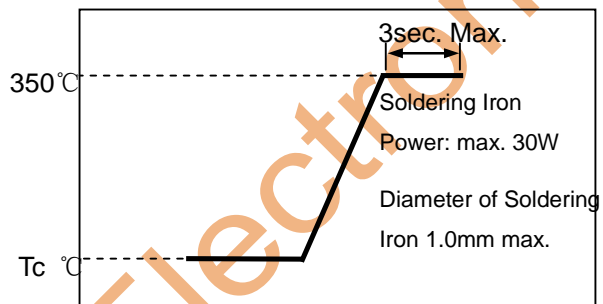

Fig. 11.2-1

12 Precautions**12.1 Surface mounting**

- Mounting and soldering condition should be checked beforehand.
- Applicable soldering process to this product is reflow soldering only.
- Recommended conditions for repair by soldering iron:
Preheat the circuit board with product to repair at 150°C for about 1 minute.
Put soldering iron on the land-pattern.
Soldering iron's temperature: 350°C maximum/Duration: 3 seconds maximum/1 time for each terminal.
The soldering iron should not directly touch the inductor.
Product once removes from the circuit board may not be used again.

12.2 Handling

- Keep the products away from all magnets and magnetic objects.
- Be careful not to subject the products to excessive mechanical shocks.
- Please avoid applying impact to the products after mounted on pc board.
- Avoid ultrasonic cleaning.

12.3 Storage

- To maintain the solderability of terminal electrodes and to keep the packing material in good condition, temperature and humidity in the storage area should be controlled.
- Recommended conditions: -10°C~40°C, 70%RH (Max.).
- Even under ideal storage conditions, solderability of products electrodes may decrease as time passes. For this reason, product should be used with one year from the time of delivery.
- In case of storage over 6 months, solderability shall be checked before actual usage.

12.4 Regarding Regulations

- Any Class- I or Class- II ozone-depleting substance (ODS) listed in the Clean Air Act in US for regulation is not included in the products or applied to the products at any stage of whose manufacturing processes.
- Certain brominated flame retardants (PBBs, PBDEs) are not used at all.
- The products of this specification are not subject to the Export Trade Control Order in China or the Export Administration Regulations in US.

12.5 Guarantee

- The guaranteed operating conditions of the products are in accordance with the conditions specified in this specification.
- Please note that Sunlord takes no responsibility for any failure and/or abnormality which is caused by use under other than the aforesaid operating conditions.

12.6 Please make sure to record the lot number on the label when using Sunlord's products in order for good traceability.