

SPECIFICATIONS

Customer	
Product Name	Multi-layer Chip Power Inductor
Sunlord Part Number	MPH160805S Series
Customer Part Number	

New Released, Revised]

SPEC No.: MPH0301210000

【This SPEC is total 10 pages including specifications and appendix.】

【ROHS, Halogen-Free and SVHC Compliant Parts】

Approved By	Checked By	Issued By

Shenzhen Sunlord Electronics Co., Ltd.

Address: Sunlord Industrial Park, Dafu Industrial Zone, Baoan, Shenzhen, China 518110
 Tel: 0086-755-29832333 Fax: 0086-755-82269029 E-Mail: sunlord@sunlordinc.com

【For Customer approval Only】

Date: _____

Qualification Status: Full Restricted Rejected

Approved By	Verified By	Re-checked By	Checked By

Comments:

【Version change history】

Rev.	Effective Date	Changed Contents	Change reasons	Approved By
01	/	New release	/	Hai Guo

Caution

All products listed in this specification are developed, designed and intended for use in general electronics equipment. The products are not designed or warranted to meet the requirements of the applications listed below, whose performance and/or quality require especially high reliability, or whose failure, malfunction or trouble might directly cause damage to society, person, or property. Please understand that we are not responsible for any damage or liability caused by use of the products in any of the applications below. Please contact us for more details if you intend to use our products in the following applications.

1. Aircraft equipment
2. Aerospace equipment
3. Undersea equipment
4. nuclear control equipment
5. military equipment
6. Power plant equipment
7. Medical equipment
8. Transportation equipment (automobiles, trains, ships,etc.)
9. Traffic signal equipment
10. Disaster prevention / crime prevention equipment
11. Data-processing equipment
12. Applications of similar complexity or with reliability requirements comparable to the applications listed in the above

1. Scope

This specification applies to MPH160805S Series of multi-layer chip power inductors.

2. Product Description and Identification (Part Number)

- 1) Description
MPH160809S Series of multi-layer chip power inductors
- 2) Product Identification (Part Number)

MPH 160805 S XXX □ T
 ① ② ③ ④ ⑤ ⑥

①	Type
MPH	Monolithic Type Power Inductor

②	External Dimensions (L x W xT) (mm)	
160805	1.6x0.8x0.5	

③	Feature Type	
S	Standard	

④	Nominal Inductance	
Example	Nominal Value	
R47	0.47μH	
1R0	1.0μH	

⑤	Inductance Tolerance	
M	±20%	
N	±30%	

⑥	Packing	
T	Tape Carrier Package	

3. Electrical Characteristics

Please refer to Appendix A (Page 10).

- 1) Operating and storage temperature range (individual chip without packing): -55°C ~ +125°C (Including Self-heating)
- 2) Storage temperature range (packaging conditions): -10°C ~ +40°C and RH 70% (Max.)

4. Shape and Dimensions

- 1) Dimensions and recommended PCB pattern for reflow soldering: See Fig.4-1, Fig.4-2 and Table 4-1.
- 2) Structure: See Fig. 4-3 and Fig. 4-4.

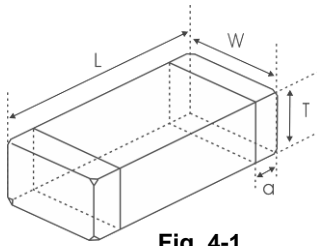

Fig. 4-1

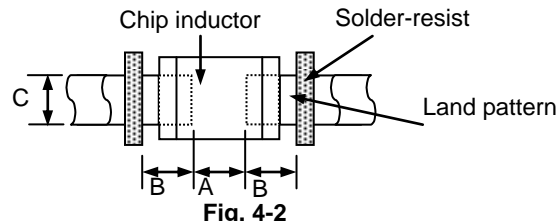

Fig. 4-2

[Table 4-1]

Unit: mm [inch]

Type	L	W	T	a	A	B	C
160805	1.60±0.15 [0.063±0.006]	0.8±0.15 [0.031±0.006]	0.5±0.05 [0.020±0.002]	0.3±0.2 [0.012±0.008]	0.70	0.70	1.0

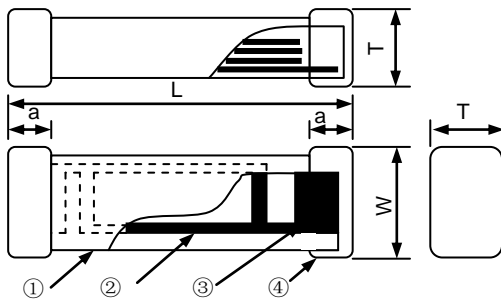

Fig. 4-3

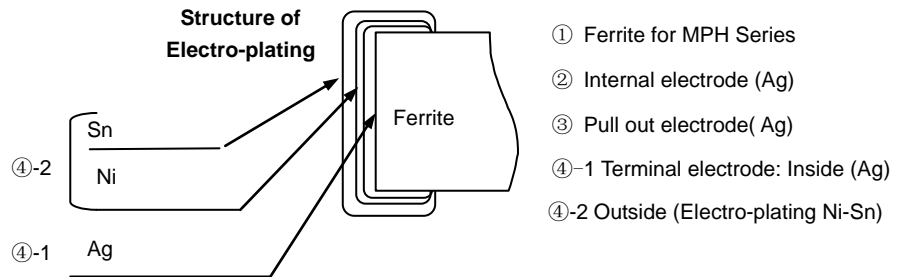

Fig. 4-4

- ① Ferrite for MPH Series
- ② Internal electrode (Ag)
- ③ Pull out electrode (Ag)
- ④-1 Terminal electrode: Inside (Ag)
- ④-2 Outside (Electro-plating Ni-Sn)

3) Material Information: See Table 4-2.

[Table 4-2]

Code	Part Name	Material Name
①	Ferrite Body	Ferrite Powder
②	Inner Coils	Silver Paste
③	Pull-out Electrode (Ag)	Silver Paste
④-1	Terminal Electrode: Inside Ag	Termination Silver Composition
④-2	Electro-Plating: Ni/Sn plating	Plating Chemicals

5. Test and Measurement Procedures

5.1 Test Conditions

5.1.1 Unless otherwise specified, the standard atmospheric conditions for measurement/test as:

- a. Ambient Temperature: 20±15°C
- b. Relative Humidity: 65±20%
- c. Air Pressure: 86kPa to 106kPa

5.1.2 If any doubt on the results, measurements/tests should be made within the following limits:

- a. Ambient Temperature: 20±2°C
- b. Relative Humidity: 65±5%
- c. Air Pressure: 86kPa to 106kPa

5.2 Visual Examination

- a. Inspection Equipment: 20x magnifier

5.3 Electrical Test

5.3.1 DC Resistance (DCR)

- a. Refer to Appendix A.
- b. Test equipment (Analyzer): High Accuracy Milliohmmeter-HP4338B or equivalent.

5.3.2 Inductance (L)

- a. Refer to Appendix A.
- b. Test equipment: High Accuracy RF Impedance /Material Analyzer-HP4291B+HP16192A or equivalent.
- c. Test signal: -20dBm or 50mV.
- d. Test frequency refers to Appendix A.

5.3.3 Temperature Rise Current (I_{rms})

- a. Refer to Appendix A.
- b. Test equipment (see Fig. 5.3.3-1): Electric Power, Electric current meter, Thermometer.
- c. Measurement method (see Fig. 5.3.3-1):
 1. Set test current to be 0mA.
 2. Measure initial temperature of chip surface.
 3. Gradually increase voltage and measure chip temperature for corresponding current.
 4. Definition of Temperature Rise Current (I_{rms}) : I_{rms} is direct electric current as chip surface temperature rose just 40°C against chip initial surface temperature (T_a) (see Fig. 5.3.3-2)

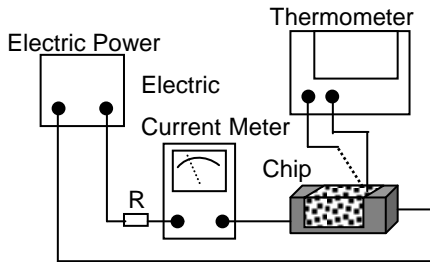

Fig. 5.3.3-1

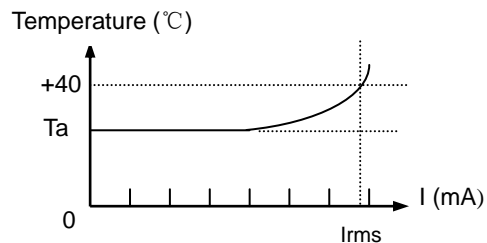

Fig. 5.3.3-2

5.3.4 Saturation Current (I_{sat})

- a. Refer to Appendix A.
- b. Test equipment: HP6632B system DC power supply, HP4291B+HP16192A+HP16200A or equivalent.
- c. Measurement method:
 1. Measurement conditions of initial inductance L: Measuring Frequency: 1MHz.
Test Current: 1mA.
 2. Definition of Saturation Current (I_{sat}) : I_{sat} is the value of DC current as inductance L (μH) decreased just 30% against initial value (see Fig. 5.3.4-1).

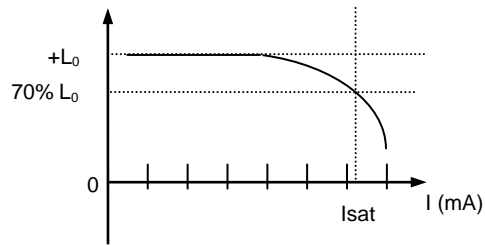

Fig. 5.3.4-1

5.3.5 Self-Resonant Frequency (SRF)

- a. Refer to **Appendix A**.
- b. Test equipment: High Accuracy RF Impedance /Material Analyzer-HP4291B+HP16192A or equivalent.
- c. Test signal: -20dBm or 50 mV.

5.4 Reliability Test

※ The land dimensions for reliability test is :

A	B	C
0.70	0.70	1.0

Unit: mm

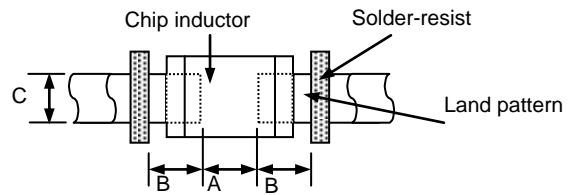

- ※ The thickness of Stencil is 0.08mm~0.1mm, add the standard thickness of solder paste: 0.10mm~0.15mm .
- ※ Solder shall be used as shown below.

$1/3T \leq L \leq T$
 (T: height of electrode)

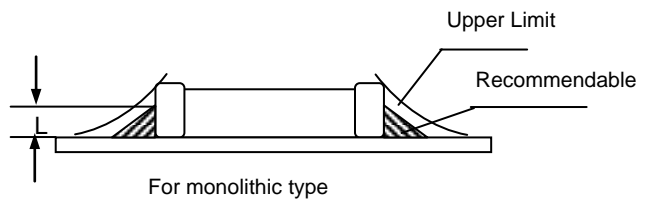

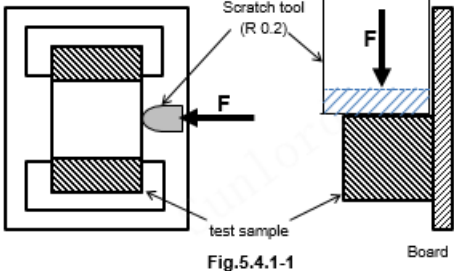
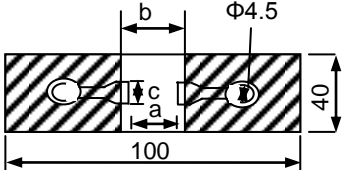
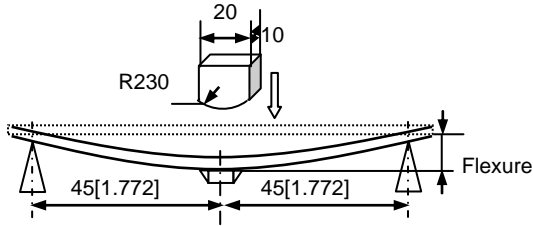
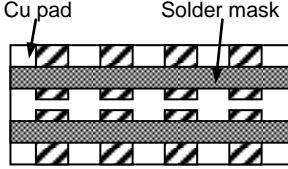
Items	Requirements	Test Methods and Remarks								
5.4.1 Terminal Strength	No removal or split of the termination or other defects shall occur.  <p style="text-align: center;">Fig.5.4.1-1</p>	<ol style="list-style-type: none"> ① Solder the inductor to the testing jig (glass epoxy board shown in Fig.5.4.1-1) using eutectic solder. Then apply a 10N force in the direction of the arrow. ② Keep time: 10±1s. ③ Speed: 1.0mm/s. ④ The Scratch tool shall keep a distance of 0.1mm from the Board. 								
5.4.2 Resistance to Flexure	No visible mechanical damage. Unit: mm [inch] <table border="1" data-bbox="359 638 778 728" style="margin-left: auto; margin-right: auto;"> <thead> <tr> <th>Type</th> <th>a</th> <th>b</th> <th>c</th> </tr> </thead> <tbody> <tr> <td>1608[0603]</td> <td>1.0</td> <td>3.0</td> <td>1.2</td> </tr> </tbody> </table>  <p style="text-align: center;">Fig.5.4.2-1</p>	Type	a	b	c	1608[0603]	1.0	3.0	1.2	<ol style="list-style-type: none"> ① Solder the inductor to the test jig (glass epoxy board shown in Fig.5.4.2-1) Using a eutectic solder. Then apply a force in the direction shown Fig. 5.4.2-2. ② Flexure: 2mm. ③ Pressurizing Speed: 0.5mm/sec. ④ Keep time: 30 sec.  <p style="text-align: center;">Fig. 5.4.2-2</p>
Type	a	b	c							
1608[0603]	1.0	3.0	1.2							
5.4.3 Vibration	<ol style="list-style-type: none"> ① No visible mechanical damage. ② Inductance change: Within ±20%.  <p style="text-align: center;">Glass Epoxy Board Fig. 5.4.3-1</p>	<ol style="list-style-type: none"> ① Solder the inductor to the testing jig (glass epoxy board shown in Fig.5.4.3-1) using eutectic solder. ② The inductor shall be subjected to a simple harmonic motion having total amplitude of 1.5mm, the frequency being varied uniformly between the approximate limits of 10 and 55 Hz. ③ The frequency range from 10 to 55 Hz and return to 10 Hz shall be traversed in approximately 1 minute. This motion shall be applied for a period of 2 hours in each 3 mutually perpendicular directions (total of 6 hours). 								
5.4.4 Dropping	<ol style="list-style-type: none"> ① No visible mechanical damage. ② Inductance change: Within ±20%. 	Drop chip inductor 10 times on a concrete floor from a height of 100 cm.								
5.4.5 Temperature	Inductance change should be within ±20% of initial value measuring at 20°C.	Temperature range: -40°C~ +85°C Reference temperature: +20°C								
5.4.6 Solderability	<ol style="list-style-type: none"> ① No visible mechanical damage. ② Wetting shall exceed 95% coverage. 	<ol style="list-style-type: none"> ① Solder temperature: 240±2°C ② Duration: 3 sec. ③ Solder: Sn/3.0Ag/0.5Cu. ④ Flux: 25% Resin and 75% ethanol in weight. 								
5.4.7 Resistance to Soldering Heat	<ol style="list-style-type: none"> ① No visible mechanical damage. ② Wetting shall exceed 95% coverage. ③ Inductance change: Within ±20%. 	<ol style="list-style-type: none"> ① Solder temperature: 260±3°C. ② Duration: 5 sec. ③ Solder: Sn/3.0Ag/0.5Cu. ④ Flux: 25% Resin and 75% ethanol in weight. ⑤ The chip shall be stabilized at normal condition for 1~2 hours before measuring. 								

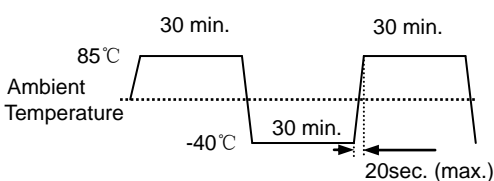
Items	Requirements	Test Methods and Remarks
5.4.8 Thermal Shock	① No mechanical damage. ② Inductance change: Within $\pm 20\%$.  <p style="text-align: center;">Fig. 5.4.8-1</p>	① Temperature, Time: (See Fig.5.4.8-1) -40°C for 30±3 min → 85°C for 30±3 min. ② Transforming interval: 20 sec.(max.). ③ Tested cycle: 100 cycles. ④ The chip shall be stabilized at normal condition for 1~2 hours before measuring.
5.4.9 Resistance to Low Temperature	① No mechanical damage. ② Inductance change: Within $\pm 20\%$.	① Temperature: $-40 \pm 2^\circ\text{C}$ ② Duration: 1000 ⁺²⁴ hours. ③ The chip shall be stabilized at normal condition for 1~2 hours before measuring.
5.4.10 Resistance to High Temperature	① No mechanical damage. ② Inductance change: Within $\pm 20\%$.	① Temperature: $85 \pm 2^\circ\text{C}$ ② Duration: 1000 ⁺²⁴ hours. ③ The chip shall be stabilized at normal condition for 1~2 hours before measuring.
5.4.11 Damp Heat (Steady States)	① No visible mechanical damage. ② Inductance change: Within $\pm 20\%$.	① Temperature: $60 \pm 2^\circ\text{C}$ ② Humidity: 90% to 95% RH. ③ Duration: 1000 ⁺²⁴ hours. ④ The chip shall be stabilized at normal condition for 1~2 hours before measuring.

6. Packaging and Storage

6.1 Packaging

Tape Carrier Packaging:

Packaging code: T

- a. Tape carrier packaging are specified in attached figure Fig.6.1-1~3
- b. Tape carrier packaging quantity please see the following table:

Type	1608[0603]
T(mm)	0.5±0.05
Tape	Paper Tape
Quantity	5K

- c. Reel shall be packaged in vinyl bag.
- d. Maximum of 5 or 10 reels bags shall be packaged in an inner box.
- e. Maximum of 6 or 10 inner boxes shall be packaged in an outer case.

(1) Taping Drawings (Unit: mm)

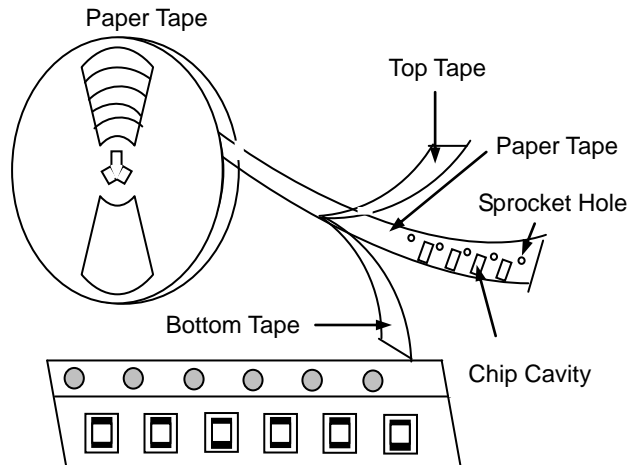

Fig. 6.1-1

Remark: The sprocket holes are to the right as the tape is pulled toward the user.

(2) Taping Dimensions (Unit: mm)

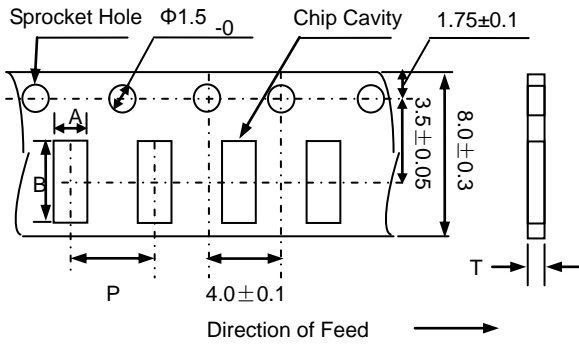

Fig. 6.1-2

Type	A	B	P	T max
MPH160805	1.0 ± 0.2	1.8 ± 0.2	4.0 ± 0.1	0.8

(3) Reel Dimensions (Unit: mm)

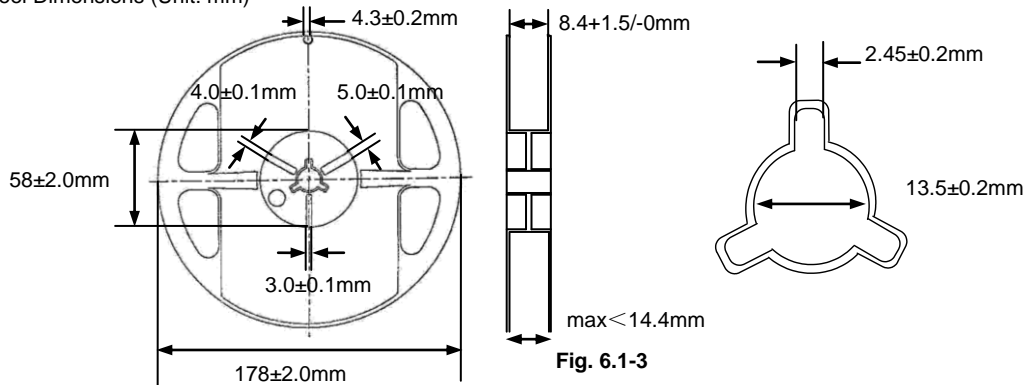

Fig. 6.1-3

6.2 Storage

- The solderability of the external electrode may be deteriorated if packages are stored where they are exposed to high humidity. Package must be stored at 40°C or less and 70% RH or less.
- The solderability of the external electrode may be deteriorated if packages are stored where they are exposed to dust of harmful gas (e.g. HCl, sulfurous gas of H_2S).
- Packaging material may be deformed if package are stored where they are exposed to heat of direct sunlight.
- Solderability specified in **Clause 5.4.6** shall be guaranteed for 12 months from the date of delivery on condition that they are stored at the environment specified in **Clause 3**. For those parts, which passed more than 12 months shall be checked solder-ability before use.

7. Recommended Soldering Technologies

7.1 Reflowing Profile:

- △ Preheat condition: $150 \sim 200^\circ\text{C}/60 \sim 120\text{sec}$.
- △ Allowed time above 217°C : $60 \sim 90\text{sec}$.
- △ Max temp: 260°C
- △ Max time at max temp: 10sec.
- △ Solder paste: Sn/3.0Ag/0.5Cu
- △ Allowed Reflow time: 2x max

[Note: The reflow profile in the above table is only for qualification and is not meant to specify board assembly profiles. Actual board assembly profiles must be based on the customer's specific board design, solder paste and process, and should not exceed the parameters as the Reflow profile shows.]

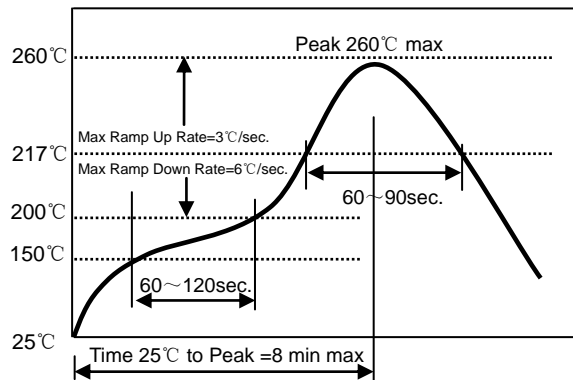

7.2 Iron Soldering Profile.

- △ Iron soldering power: Max.30W
- △ Pre-heating: $150^\circ\text{C} / 60\text{sec}$.
- △ Soldering Tip temperature: 350°C Max.
- △ Soldering time: 3sec Max.
- △ Solder paste: Sn/3.0Ag/0.5Cu
- △ Max.1 times for iron soldering

[Note: Take care not to apply the tip of the soldering iron to the terminal electrodes.]

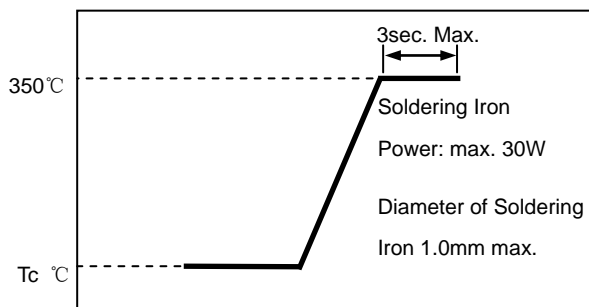

Appendix A: Electrical Characteristics

Part Number	L (μ H)	L Test Freq. (MHz)	S.R.F Min. (MHz)	DCR (Typ) (Ω)	DCR (Max) (Ω)	Temperature Rise Current I _{rms} (max.) (mA)	Saturation Current I _{sat} (Typ.) (mA)	Saturation Current I _{sat} (Max.) (mA)	Thickness (mm) [inch]
MPH160805SR22□T	0.22	1	180	0.120	0.150	1200	1450	1200	0.5±0.05 [0.020±0.002]
MPH160805SR33□T	0.33	1	140	0.160	0.200	1100	1350	1100	
MPH160805SR47□T	0.47	1	120	0.180	0.225	1150	1050	850	
MPH160805SR68□T	0.68	1	100	0.220	0.275	900	800	650	
MPH160805S1R0□T	1.0	1	90	0.320	0.400	800	700	580	
MPH160805S1R5□T	1.5	1	80	0.380	0.475	650	400	300	
MPH160805S2R2□T	2.2	1	60	0.420	0.525	600	250	180	

※□: Please specify the inductance tolerance code (M=±20%, N=±30%).