

【Version change history】

Rev.	Effective Date	Changed Contents	Change Reasons	Approved By
01	/	New release	/	Hai Guo

Caution

All products listed in this specification are developed, designed and intended for use in general electronics equipment. The products are not designed or warranted to meet the requirements of the applications listed below, whose performance and/or quality require especially high reliability, or whose failure, malfunction or trouble might directly cause damage to society, person, or property. Please understand that we are not responsible for any damage or liability caused by use of the products in any of the applications below. Please contact us for more details if you intend to use our products in the following applications.

1. Aircraft equipment
2. Aerospace equipment
3. Undersea equipment
4. nuclear control equipment
5. military equipment
6. Power plant equipment
7. Medical equipment
8. Transportation equipment (automobiles, trains, ships,etc.)
9. Traffic signal equipment
10. Disaster prevention / crime prevention equipment
11. Data-processing equipment
12. Applications of similar complexity or with reliability requirements comparable to the applications listed in the above

1. Scope

This specification applies to SDFL Series of multi-layer ferrite chip inductors.

2. Product Description and Identification (Part Number)

- 1) Description
SDFL series of multi-layer chip ferrite inductors.
- 2) Product Identification (Part Number)

SDFL ※※※※ ○ XXX □ ◎ F (A99)
 ① ② ③ ④ ⑤ ⑥ ⑦ ⑧

①	Type
SDFL	Chip Ferrite Inductor

②	External Dimensions (L X W) (mm)	
	1005 [0402]	1.0 X 0.5
	1608 [0603]	1.6 X 0.8
	2012 [0805]	2.0 X 1.25
	3216 [1206]	3.2 X 1.6

③	Material Code
	L, B, P, Q, S, T

⑤	Inductance Tolerance	
K		±10%
M		±20%

④	Nominal Inductance	
	Example	Nominal Value
	47N	0.047μH
	R10	0.1μH
	1R0	1.0μH
	100	10μH

⑥	Packing
T	Tape Carrier Package

⑦	HSF Products
	Hazardous Substance Free Products

⑧	Internal Code
	A99

3. Electrical Characteristics

Please refer to **Appendix A** (Page 9~14).

- 1) Operating and storage temperature range (individual chip without packing): -40°C ~ +85°C
- 2) Storage temperature range (packaging conditions): -10°C~+40°C and RH 70% (Max.)

4. Shape and Dimensions

- 1) Dimensions and recommended PCB pattern for reflow soldering: See **Fig.4-1**, **Fig.4-2** and **Table 4-1**.
- 2) Structure: See **Fig. 4-3** and **Fig. 4-4**.

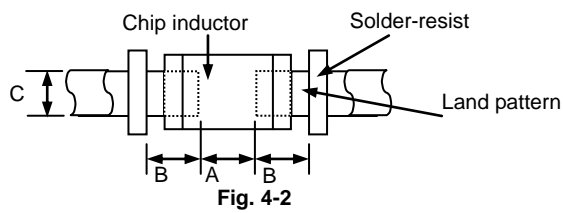
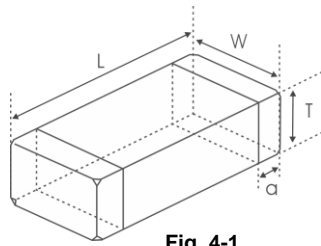

[Table 4-1]

Unit: mm [inch]

Type	L	W	T	a	A	B	C
1005 [0402]	1.0±0.15 [0.039±0.006]	0.5±0.15 [0.020±0.006]	0.5±0.15 [0.020±0.006]	0.25±0.1 [0.010±0.004]	0.45~0.55	0.40~0.50	0.45~0.55
1608 [0603]	1.60±0.15 [0.063±0.006]	0.8±0.15 [0.031±0.006]	0.8±0.15 [0.031±0.006]	0.3±0.2 [0.012±0.008]	0.60~0.80	0.60~0.80	0.60~0.80
2012 [0805]	2.0 (+0.3, -0.1) [0.079 (+0.012, -0.004)]	1.25±0.2 [0.049±0.008]	0.85±0.2[0.033±0.008]	0.5±0.3 [0.020±0.012]	0.80~1.20	0.80~1.20	0.90~1.60
			1.25±0.2[0.049±0.008]				
3216 [1206]	3.2±0.2 [0.126±0.008]	1.6±0.2 [0.063±0.008]	0.85±0.2[0.033±0.008]	0.5±0.3 [0.020±0.012]	1.80~2.50	1.00~1.50	1.20~2.00
			1.1±0.2[0.043±0.008]				

Note: The details of different thickness for different products see **Appendix A**.

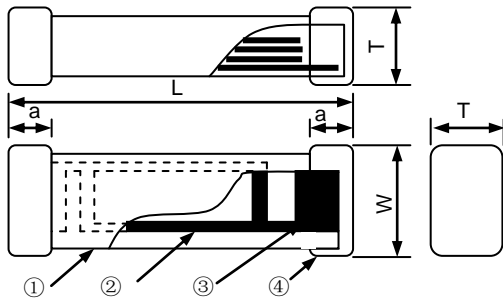

Fig. 4-3

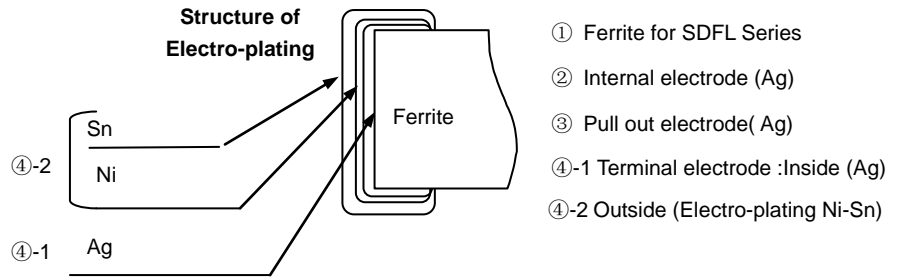

Fig. 4-4

3) Material Information: See Table 4-2.

[Table 4-2]

Code	Part Name	Material Name
①	Ferrite Body	Ferrite Powder
②	Inner Coils	Silver Paste
③	Pull-out Electrode (Ag)	Silver Paste
④-1	Terminal Electrode: Inside Ag	Termination Silver Composition
④-2	Electro-Plating: Ni/Sn plating	Plating Chemicals

5. Test and Measurement Procedures

5.1 Test Conditions

Unless otherwise specified, the standard atmospheric conditions for measurement/test as:

- a. Ambient Temperature: 20±15℃
- b. Relative Humidity: 65±20%
- c. Air Pressure: 86kPa to 106kPa

If any doubt on the results, measurements/tests should be made within the following limits:

- a. Ambient Temperature: 20±2℃
- b. Relative Humidity: 65±5%
- c. Air Pressure: 86kPa to 106kPa

5.2 Visual Examination

- a. Inspection Equipment: 20x magnifier

5.3 Electrical Test

5.3.1 DC Resistance (DCR)

- a. Refer to **Appendix A**.
- b. Test equipment (Analyzer): High Accuracy Milliohmmeter-HP4338B or equivalent.

5.3.2 Inductance (L)

- a. Refer to **Appendix A**.
- b. Test equipment: High Accuracy RF Impedance /Material Analyzer-HP4291B+HP16192A or equivalent.
- c. Test signal: -20dBm or 50mV.
- d. Test frequency refers to **Appendix A**.

5.3.3 Q Factor (Q)

- a. Refer to **Appendix A**.
- b. Test equipment: High Accuracy RF Impedance /Material Analyzer-HP4291B+HP16192A or equivalent.
- c. Test signal: -20dBm or 50mV.
- d. Test frequency refers to **Appendix A**.

5.3.4 Self-Resonant Frequency (SRF)

- a. Refer to **Appendix A**.
- b. Test equipment: High Accuracy RF Impedance /Material Analyzer-HP4291B+HP16192A or equivalent.
- c. Test signal: -20dBm or 50 mV.

5.3.5 Rated Current

- a. Refer to **Appendix A**.
- b. Test equipment (see Fig.5.3.5-1): Electric Power, Electric current meter, HP4291B+HP16192A or equivalent.
- c. Measurement method (see Fig. 5.3.5-1):
 1. Measurement conditions of initial inductance L:
 - Measuring Frequency: 1MHz,
 - Test Current: 0.047μH~4.7μH, 1mA ; 5.6μH~100μH, 0.1mA.
 2. Raising the voltage of the DC power supply, measure the inductance at the various current.

The rated current is the current value at which the inductance will be 5% down compared with the initial inductance value.

Note: In the period of raising voltage, voltage cannot be reduced.

- d. Definition of Rated Current (I_r): I_r is direct electric current as inductance L (μH) decreased just 5% against initial value (see Fig. 5.3.5-2).

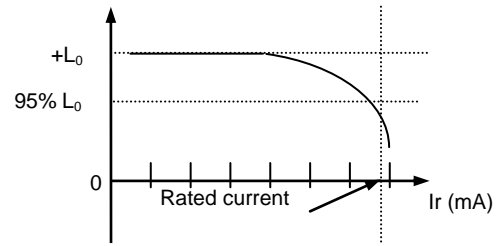
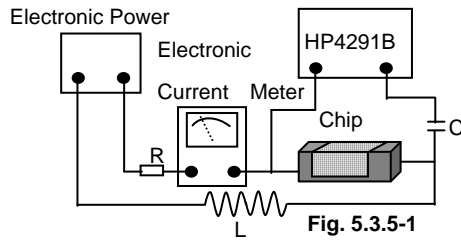

Fig. 5.3.5-2

5.4 Reliability Test

Items	Requirements	Test Methods and Remarks																				
5.4.1 Terminal Strength	<p>No removal or split of the termination or other defects shall occur.</p>	<ol style="list-style-type: none"> Solder the inductor to the testing jig (glass epoxy board shown in Fig.5.4.1-1) using leadfree solder. Then apply a force in the direction of the arrow. 5N force for SDFL1005 and 1608 series. 10N force for SDFL2012 and 3216 series. Keep time: 10±1s. Speed: 1.0mm/s. 																				
5.4.2 Resistance to Flexure	<p>No visible mechanical damage.</p> <table border="1"> <thead> <tr> <th>Type</th> <th>a</th> <th>b</th> <th>c</th> </tr> </thead> <tbody> <tr> <td>1005[0402]</td> <td>0.42</td> <td>1.5</td> <td>0.5</td> </tr> <tr> <td>1608[0603]</td> <td>1.0</td> <td>3.0</td> <td>1.2</td> </tr> <tr> <td>2012[0805]</td> <td>1.2</td> <td>4.0</td> <td>1.65</td> </tr> <tr> <td>3216[1206]</td> <td>2.2</td> <td>5.0</td> <td>2.0</td> </tr> </tbody> </table> <p>Unit: mm [inch]</p>	Type	a	b	c	1005[0402]	0.42	1.5	0.5	1608[0603]	1.0	3.0	1.2	2012[0805]	1.2	4.0	1.65	3216[1206]	2.2	5.0	2.0	<ol style="list-style-type: none"> Solder the inductor to the test jig (glass epoxy board shown in Fig.5.4.2-1) Using a leadfree solder. Then apply a force in the direction shown Fig. 5.4.2-2. Flexure: 2mm. Pressurizing Speed: 0.5mm/sec. Keep time: 30 sec.
Type	a	b	c																			
1005[0402]	0.42	1.5	0.5																			
1608[0603]	1.0	3.0	1.2																			
2012[0805]	1.2	4.0	1.65																			
3216[1206]	2.2	5.0	2.0																			
5.4.3 Vibration	<ol style="list-style-type: none"> No visible mechanical damage. Inductance change: Within ±10% Q factor change: Within ±30% 	<ol style="list-style-type: none"> Solder the inductor to the testing jig (glass epoxy board shown in Fig.5.4.3-1) using leadfree solder. The inductor shall be subjected to a simple harmonic motion having total amplitude of 1.5mm, the frequency being varied uniformly between the approximate limits of 10 and 55 Hz. The frequency range from 10 to 55 Hz and return to 10 Hz shall be traversed in approximately 1 minute. This motion shall be applied for a period of 2 hours in each 3 mutually perpendicular directions (total of 6 hours). 																				
5.4.4 Dropping	<ol style="list-style-type: none"> No visible mechanical damage. Inductance change: Within ±10%. Q factor change: Within ±30%. 	Drop chip inductor 10 times on a concrete floor from a height of 100 cm.																				
5.4.5 Temperature	Inductance change should be within ±10% of initial value measuring at 20°C.	Temperature range: -40°C ~ +85°C Reference temperature: +20°C																				
5.4.6 Solderability	<ol style="list-style-type: none"> No visible mechanical damage. Wetting shall exceed 95% coverage. 	<ol style="list-style-type: none"> Solder temperature: 240±2°C Duration: 3sec. Solder: Sn/3.0Ag/0.5Cu. Flux: 25% Resin and 75% ethanol in weight. 																				

5.4.7 Resistance to Soldering Heat	① No visible mechanical damage. ② Wetting shall exceed 95% coverage. ③ Inductance change: Within $\pm 10\%$. ④ Q factor change: Within $\pm 30\%$.	① Solder temperature: $260 \pm 3^\circ\text{C}$. ② Duration: 5sec. ③ Solder: Sn/3.0Ag/0.5Cu. ④ Flux: 25% Resin and 75% ethanol in weight. ⑤ The chip shall be stabilized at normal condition for 1~2 hours before measuring.
5.4.8 Thermal Shock	① No mechanical damage. ② Inductance change: Within $\pm 10\%$. ③ Q factor change: Within $\pm 30\%$.	① Temperature, Time: (See Fig.5.4.8-1) -40°C for 30 ± 3 min \rightarrow 85°C for 30 ± 3 min. ② Transforming interval: 20 sec.(max.). ③ Tested cycle: 100 cycles. ④ The chip shall be stabilized at normal condition for 1~2 hours before measuring.
<p>Fig. 5.4.8-1</p>		
5.4.9 Resistance to Low Temperature	① No mechanical damage. ② Inductance change: Within $\pm 10\%$. ③ Q factor change: Within $\pm 30\%$.	① Temperature: $-40 \pm 2^\circ\text{C}$ ② Duration: 1000^{+24} hours. ③ The chip shall be stabilized at normal condition for 1~2 hours before measuring.
5.4.10 Resistance to High Temperature	① No mechanical damage. ② Inductance change: Within $\pm 10\%$. ③ Q factor change: Within $\pm 30\%$.	① Temperature: $85 \pm 2^\circ\text{C}$ ② Duration: 1000^{+24} hours. ③ The chip shall be stabilized at normal condition for 1~2 hours before measuring.
5.4.11 Damp Heat (Steady States)	① No visible mechanical damage. ② Inductance change: Within $\pm 10\%$. ③ Q factor change: Within $\pm 30\%$.	① Temperature: $60 \pm 2^\circ\text{C}$ ② Humidity: 90% to 95% RH. ③ Duration: 1000^{+24} hours. ④ The chip shall be stabilized at normal condition for 1~2 hours before measuring.
5.4.12 Loading Under Damp Heat	① No visible mechanical damage. ② Inductance change: within $\pm 10\%$ for inductance $\leq 12\mu\text{H}$ within $\pm 15\%$ for inductance $\geq 15\mu\text{H}$. ③ Q factor change: Within $\pm 30\%$.	① Temperature: $60 \pm 2^\circ\text{C}$ ② Humidity: 90% to 95% RH. ③ Duration: 1000^{+24} hours. ④ Applied current: Rated current. ⑤ The chip shall be stabilized at normal condition for 1~2 hours before measuring.
5.4.13 Loading at High Temperature (Life Test)	① No visible mechanical damage. ② Inductance change: within $\pm 10\%$ for inductance $\leq 12\mu\text{H}$ within $\pm 15\%$ for inductance $\geq 15\mu\text{H}$. ③ Q factor change: Within $\pm 30\%$.	① Temperature: $85 \pm 2^\circ\text{C}$ ② Duration: 1000^{+24} hours. ③ Applied current: Rated current. ④ The chip shall be stabilized at normal condition for 1~2 hours before measuring.

6. Packaging, Storage

6.1 Packaging

Tape Carrier Packaging:

Packaging code: T

- a. Tape carrier packaging are specified in attached figure Fig.6.1-1~4
- b. Tape carrier packaging quantity please see the following table:

Type	1005[0402]	1608[0603]	2012[0805]		3216[1206]	
T(mm)	0.5 \pm 0.15	0.8 \pm 0.15	0.85 \pm 0.2	1.25 \pm 0.2	0.85 \pm 0.2	1.1 \pm 0.2
Tape	Paper Tape	Paper Tape	Paper Tape	Embossed Tape	Paper Tape	Embossed Tape
Quantity	10K	4K	4K	3K	3K	3K

(1) Taping Drawings (Unit: mm)

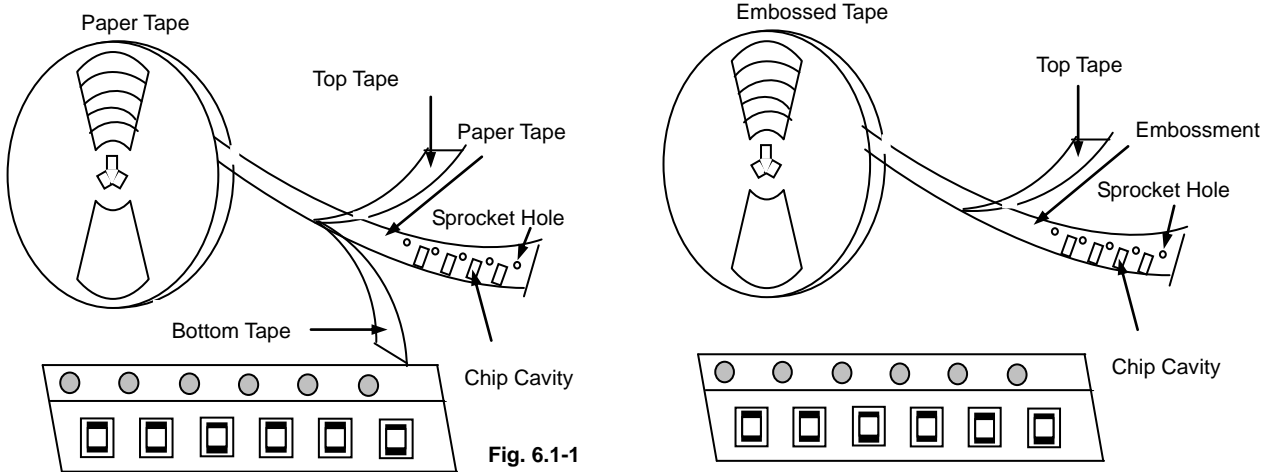

Fig. 6.1-1

Remark: The sprocket holes are to the right as the tape is pulled toward the user.

(2) Taping Dimensions (Unit: mm)

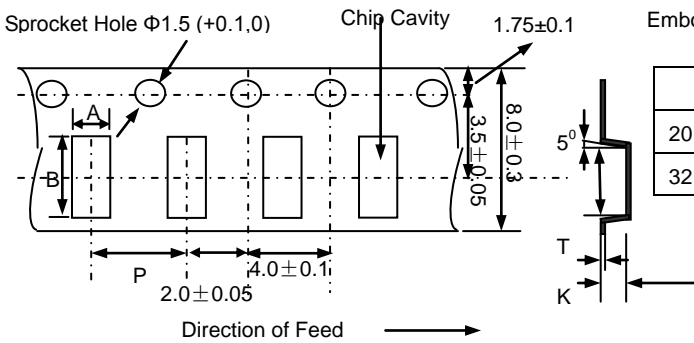

Fig. 6.1-2

Type	A	B	P	Kmax	Tmax
2012[0805]	1.55±0.2	2.25±0.2	4.0±0.1	1.45	0.3
3216[1206]	1.88±0.2	3.5±0.2	4.0±0.1	1.27	0.3

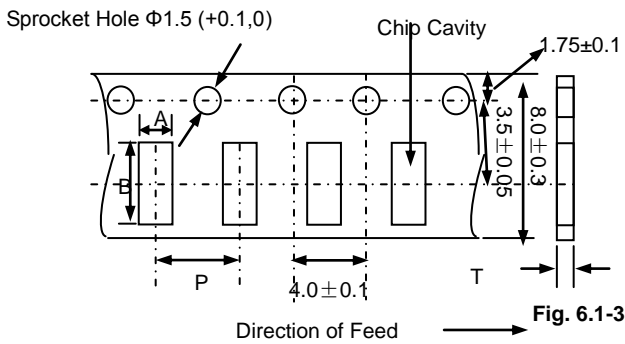

Fig. 6.1-3

Type	A	B	P	T max
1005[0402]	0.65±0.1	1.15±0.1	2.0±0.05	0.8
1608[0603]	1.0±0.2	1.8±0.2	4.0±0.1	1.1
2012[0805]	1.5±0.2	2.3±0.2	4.0±0.1	1.1
3216[1206]	1.9±0.2	2.3±0.2	4.0±0.1	1.1

(3) Reel Dimensions (Unit: mm)

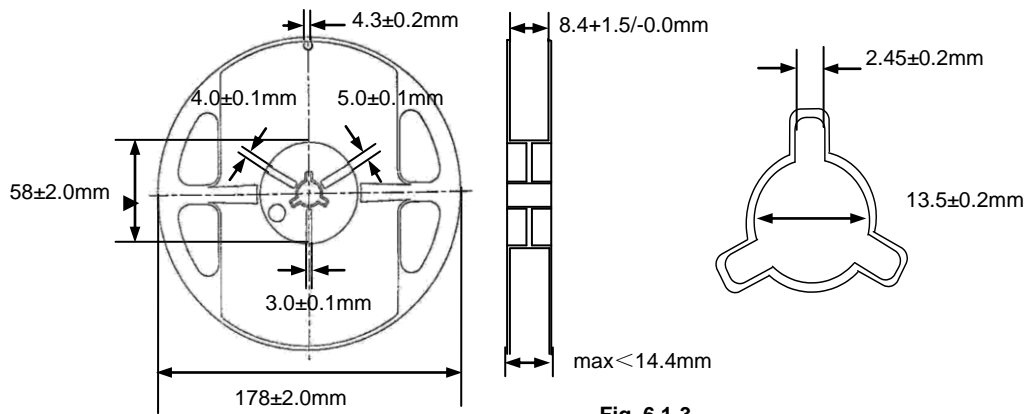

Fig. 6.1-3

6.2 Storage

- a. The solderability of the external electrode may be deteriorated if packages are stored where they are exposed to high humidity. Package must be stored at 40°C or less and 70% RH or less.
- b. The solderability of the external electrode may be deteriorated if packages are stored where they are exposed to dust of harmful gas (e.g. HCl, sulfurous gas of H₂S).
- c. Packaging material may be deformed if package are stored where they are exposed to heat of direct sunlight.
- d. Solderability specified in **Clause 5.4.6** shall be guaranteed for 12 months from the date of delivery on condition that they are stored at the environment specified in **Clause 3** .For those parts, which passed more than 12 months shall be checked solder-ability before use.

7. Recommended Soldering Technologies

7.1 Re-flowing Profile:

- △ Preheat condition: 150 ~200°C/60~120sec.
- △ Allowed time above 217C: 60~90sec.
- △ Max temp: 260°C
- △ Max time at max temp: 10sec.
- △ Solder paste: Sn/3.0Ag/0.5Cu
- △ Allowed Reflow time: 2x max

[Note: The reflow profile in the above table is only for qualification and is not meant to specify board assembly profiles. Actual board assembly profiles must be based on the customer's specific board design, solder paste and process, and should not exceed the parameters as the Reflow profile shows.]

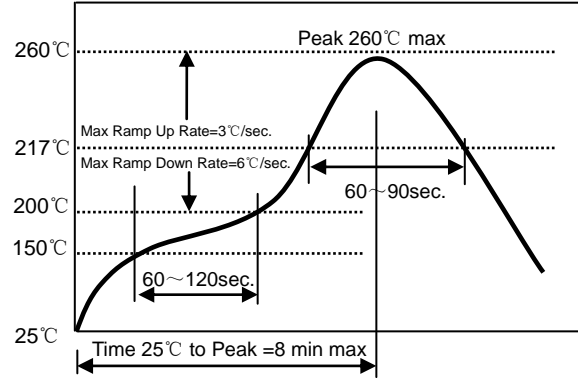

7.2 Iron Soldering Profile.

- △ Iron soldering power: Max.30W.
- △ Pre-heating: 150 °C / 60sec.
- △ Soldering Tip temperature: 350°C Max.
- △ Soldering time: 3sec Max.
- △ Solder paste: Sn/3.0Ag/0.5Cu.
- △ Max.1 times for iron soldering.

[Note: Take care not to apply the tip of the soldering iron to the terminal electrodes.]

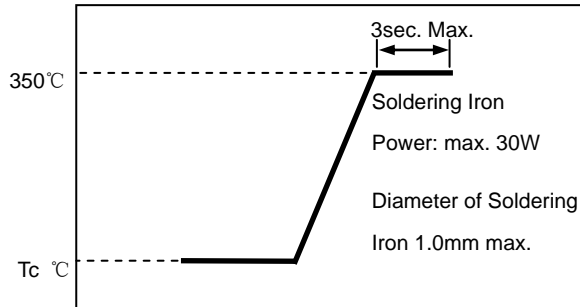

Appendix A: Electrical Characteristics

SDFL1005 Series

Part Number	L (μ H)	Q Min.	L, Q Test. Freq. (MHz)	S.R.F Min. (MHz)	DCR Max. (Ω)	I _r Max. (mA)	Thickness (mm) [inch]
SDFL1005L47N□TF	0.047	10	50	220	0.45	25	0.5±0.15 [0.020±0.006]
SDFL1005L68N□TF	0.068	10	50	210	0.45	25	
SDFL1005L82N□TF	0.082	10	50	200	0.45	25	
SDFL1005LR10□TF	0.1	10	25	200	0.8	25	
SDFL1005LR12□TF	0.12	10	25	165	0.8	25	
SDFL1005LR15□TF	0.15	10	25	140	0.9	25	
SDFL1005LR18□TF	0.18	10	25	120	0.9	25	
SDFL1005LR22□TF	0.22	10	25	110	1.2	25	
SDFL1005LR27□TF	0.27	15	25	95	1.2	25	
SDFL1005LR33□TF	0.33	15	25	85	1.25	18	
SDFL1005QR39□TF	0.39	20	10	85	0.6	15	
SDFL1005QR47□TF	0.47	20	10	80	0.7	15	
SDFL1005QR56□TF	0.56	20	10	75	0.8	15	
SDFL1005QR68□TF	0.68	20	10	70	0.9	15	
SDFL1005QR82□TF	0.82	20	10	65	0.9	15	
SDFL1005P1R0□TF	1.0	20	10	60	1.0	15	
SDFL1005P1R2□TF	1.2	20	10	55	1.25	15	
SDFL1005P1R5□TF	1.5	20	10	50	1.4	15	
SDFL1005P1R8□TF	1.8	20	10	45	1.55	15	
SDFL1005P2R2□TF	2.2	20	10	40	1.7	10	
SDFL1005Q1R0□TF	1.0	20	10	40	0.9	15	
SDFL1005Q1R2□TF	1.2	20	10	35	1.2	15	
SDFL1005Q1R5□TF	1.5	20	10	30	1.2	15	
SDFL1005Q1R8□TF	1.8	20	10	30	1.45	15	
SDFL1005Q2R2□TF	2.2	20	10	28	1.7	10	
SDFL1005Q2R7□TF	2.7	20	10	28	2.4	10	
SDFL1005Q3R3□TF	3.3	20	10	28	2.7	10	

※□: Please specify the inductance tolerance code (K=±10%, M=±20%). The product with tolerance less than ±10%, ±20% is also available.

SDFL1608 Series

Part Number	L (μ H)	Q Min.	L, Q Test. Freq. (MHz)	S.R.F Min. (MHz)	DCR Max. (Ω)	I _r Max. (mA)	Thickness (mm) [inch]
SDFL1608L47N□TF	0.047	10	50	260	0.3	50	0.8±0.15 [0.031±0.006]
SDFL1608L68N□TF	0.068	10	50	250	0.3	50	
SDFL1608L82N□TF	0.082	10	50	245	0.3	50	
SDFL1608LR10□TF	0.1	15	25	240	0.5	50	
SDFL1608LR12□TF	0.12	15	25	205	0.5	50	
SDFL1608LR15□TF	0.15	15	25	180	0.6	50	
SDFL1608LR18□TF	0.18	15	25	165	0.6	50	
SDFL1608LR22□TF	0.22	15	25	150	0.8	50	
SDFL1608LR27□TF	0.27	15	25	136	0.8	50	
SDFL1608LR33□TF	0.33	15	25	125	0.85	35	
SDFL1608LR39□TF	0.39	15	25	110	1	35	
SDFL1608LR47□TF	0.47	15	25	105	1.35	35	
SDFL1608LR56□TF	0.56	15	25	95	1.55	35	
SDFL1608LR68□TF	0.68	15	25	90	1.7	35	
SDFL1608LR82□TF	0.82	15	25	85	2.1	35	
SDFL1608P1R0□TF	1.0	35	10	90	0.6	25	
SDFL1608P1R1□TF	1.1	35	10	90	0.6	25	
SDFL1608P1R2□TF	1.2	35	10	85	0.8	25	
SDFL1608P1R5□TF	1.5	35	10	80	0.8	25	
SDFL1608P1R8□TF	1.8	35	10	75	0.95	25	
SDFL1608P2R2□TF	2.2	35	10	70	1.15	15	
SDFL1608Q1R0□TF	1.0	35	10	75	0.6	25	
SDFL1608Q1R1□TF	1.1	35	10	75	0.6	25	
SDFL1608Q1R2□TF	1.2	35	10	65	0.8	25	
SDFL1608Q1R5□TF	1.5	35	10	60	0.8	25	
SDFL1608Q1R8□TF	1.8	35	10	55	0.95	25	
SDFL1608Q2R2□TF	2.2	35	10	50	1.15	15	
SDFL1608Q2R7□TF	2.7	35	10	45	1.35	15	
SDFL1608Q3R3□TF	3.3	35	10	40	1.55	15	
SDFL1608Q3R9□TF	3.9	35	10	35	1.7	15	
SDFL1608Q4R7□TF	4.7	35	10	33	2.1	15	
SDFL1608S5R6□TF	5.6	35	4	22	1.55	5	
SDFL1608S6R8□TF	6.8	35	4	20	1.7	5	
SDFL1608S8R2□TF	8.2	35	4	18	2.1	5	
SDFL1608S100□TF	10	30	2	17	1.85	3	
SDFL1608S120□TF	12	30	2	15	2.1	3	
SDFL1608T150□TF	15	20	1	14	1.7	1	
SDFL1608T180□TF	18	20	1	13	1.85	1	
SDFL1608T220□TF	22	20	1	11	2.1	1	
SDFL1608T270□TF	27	20	1	10	2.75	1	
SDFL1608T330□TF	33	20	1	9	2.95	1	

※□: Please specify the inductance tolerance code (K=±10%, M=±20%). The product with tolerance less than ±10%, ±20% is also available.

SDFL2012 Series

Part Number	L(μH)	Q Min.	L, Q Test. Freq. (MHz)	S.R.F Min. (MHz)	DCR Max. (Ω)	I _r Max (mA)	Thickness (mm) [inch]
SDFL2012L47N□TF	0.047	15	50	320	0.2	300	0.85±0.2 [0.033±0.008]
SDFL2012L68N□TF	0.068	15	50	280	0.2	300	
SDFL2012L82N□TF	0.082	15	50	255	0.2	300	
SDFL2012LR10□TF	0.1	20	25	235	0.3	250	
SDFL2012LR12□TF	0.12	20	25	220	0.3	250	
SDFL2012LR15□TF	0.15	20	25	200	0.4	250	
SDFL2012LR18□TF	0.18	20	25	185	0.4	250	
SDFL2012LR22□TF	0.22	20	25	170	0.5	250	
SDFL2012LR27□TF	0.27	20	25	150	0.5	250	
SDFL2012LR33□TF	0.33	20	25	145	0.55	250	
SDFL2012LR39□TF	0.39	25	25	135	0.65	200	
SDFL2012LR47□TF	0.47	25	25	125	0.65	200	
SDFL2012LR56□TF	0.56	25	25	115	0.75	150	
SDFL2012LR68□TF	0.68	25	25	105	0.8	150	
SDFL2012LR82□TF	0.82	25	25	100	1	150	
SDFL2012P1R0□TF	1.0	45	10	95	0.4	50	
SDFL2012P1R2□TF	1.2	45	10	85	0.5	50	
SDFL2012P1R5□TF	1.5	45	10	80	0.5	50	
SDFL2012P1R8□TF	1.8	45	10	75	0.6	50	
SDFL2012P2R2□TF	2.2	45	10	70	0.65	30	
SDFL2012Q1R0□TF	1.0	45	10	75	0.4	50	
SDFL2012Q1R1□TF	1.1	45	10	65	0.5	50	
SDFL2012Q1R2□TF	1.2	45	10	65	0.5	50	
SDFL2012Q1R5□TF	1.5	45	10	60	0.5	50	
SDFL2012Q1R8□TF	1.8	45	10	55	0.6	50	
SDFL2012Q2R2□TF	2.2	45	10	50	0.65	30	
SDFL2012Q2R4□TF	2.4	45	10	47	0.70	30	
SDFL2012Q2R7□TF	2.7	45	10	45	0.75	30	
SDFL2012Q3R3□TF	3.3	45	10	41	0.8	30	
SDFL2012Q3R9□TF	3.9	45	10	38	0.9	30	
SDFL2012Q4R7□TF	4.7	45	10	35	1	30	
SDFL2012S5R6□TF	5.6	50	4	32	0.9	15	
SDFL2012S6R8□TF	6.8	50	4	29	1	15	
SDFL2012S8R2□TF	8.2	50	4	26	1.1	15	
SDFL2012S100□TF	10	50	2	24	1.15	15	
SDFL2012S120□TF	12	50	2	22	1.25	15	
SDFL2012T150□TF	15	30	1	19	0.8	5	
SDFL2012T180□TF	18	30	1	18	0.9	5	
SDFL2012T220□TF	22	30	1	16	1.1	5	
SDFL2012T270□TFA99	27	30	1	14	1.15	5	1.25±0.2 [0.049±0.008]
SDFL2012T330□TFA99	33	30	0.4	13	1.25	5	
SDFL2012T390□TFA99	39	35	2	8	2.9	4	
SDFL2012T470□TFA99	47	35	2	7.5	3	4	
SDFL2012Q2R2□TFA99	2.2	45	10	50	0.65	30	
SDFL2012Q3R3□TFA99	3.3	45	10	41	0.8	30	
SDFL2012Q4R7□TFA99	4.7	45	10	47	1	30	

※□: Please specify the inductance tolerance code (K=±10%, M=±20%). The product with tolerance less than ±10%, ±20% is also available.

SDFL3216 Series

Part Number	L (μH)	Q Min.	L, Q Test Freq. (MHz)	S.R.F Min. (MHz)	DCR Max. (Ω)	Ir Max (mA)	Thickness (mm) [inch]
SDFL3216L47N□TF	0.047	20	50	320	0.15	300	0.85±0.2 [0.033±0.008]
SDFL3216L68N□TF	0.068	20	50	280	0.25	300	
SDFL3216LR10□TF	0.1	20	25	235	0.25	250	
SDFL3216LR12□TF	0.12	20	25	220	0.3	250	
SDFL3216LR15□TF	0.15	20	25	200	0.3	250	
SDFL3216LR18□TF	0.18	20	25	185	0.4	250	
SDFL3216LR22□TF	0.22	20	25	170	0.4	250	
SDFL3216LR27□TF	0.27	20	25	150	0.5	250	
SDFL3216LR33□TF	0.33	20	25	145	0.6	250	
SDFL3216LR39□TF	0.39	25	25	135	0.5	200	
SDFL3216LR47□TF	0.47	25	25	125	0.6	200	
SDFL3216LR56□TF	0.56	25	25	115	0.7	150	
SDFL3216LR68□TF	0.68	25	25	105	0.8	150	
SDFL3216LR82□TF	0.82	25	25	100	0.9	150	
SDFL3216Q1R0□TF	1.0	45	10	75	0.4	100	
SDFL3216Q1R2□TF	1.2	45	10	65	0.5	100	
SDFL3216Q1R5□TF	1.5	45	10	60	0.5	50	
SDFL3216Q1R8□TF	1.8	45	10	55	0.5	50	
SDFL3216Q2R2□TF	2.2	45	10	50	0.6	50	
SDFL3216Q2R7□TF	2.7	45	10	45	0.6	50	
SDFL3216Q3R3□TF	3.3	45	10	41	0.7	50	
SDFL3216Q3R9□TF	3.9	45	10	38	0.8	50	
SDFL3216Q4R7□TF	4.7	45	10	35	0.9	50	
SDFL3216S5R6□TF	5.6	50	4	32	0.7	25	
SDFL3216S6R8□TF	6.8	50	4	29	0.8	25	
SDFL3216S8R2□TF	8.2	50	4	26	0.9	25	
SDFL3216S100□TF	10	50	2	24	1	25	
SDFL3216S120□TF	12	50	2	22	1.05	15	
SDFL3216T150□TF	15	35	1	19	0.7	5	
SDFL3216T180□TF	18	35	1	18	0.7	5	
SDFL3216T220□TF	22	35	1	16	0.9	5	
SDFL3216T270□TF	27	35	1	14	0.9	5	
SDFL3216T330□TFA99	33	35	0.4	13	1.05	5	1.10±0.2 [0.043±0.008]
SDFL3216T390□TFA99	39	40	2	11	3	5	
SDFL3216T470□TFA99	47	40	2	10	3.4	5	

※□: Please specify the inductance tolerance code (K=±10%, M=±20%). The product with tolerance less than ±10%, ±20% is also available.

Inductance Frequency Characteristics

B, P, Q 三种材料电感的区别

Q vs. Frequency Characteristics

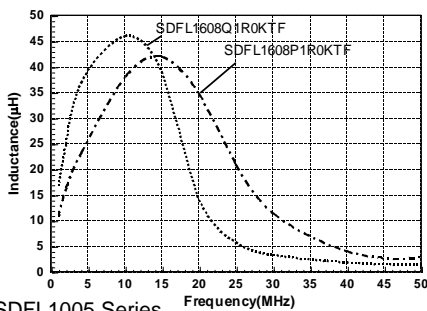

Inductance vs. DC Current Characteristics

B, P, Q Material Comparison

Inductance vs. Frequency Characteristics

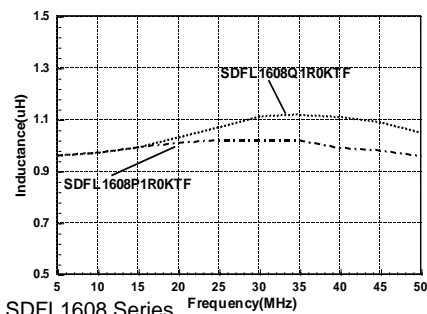

Inductance vs. DC Current Characteristics

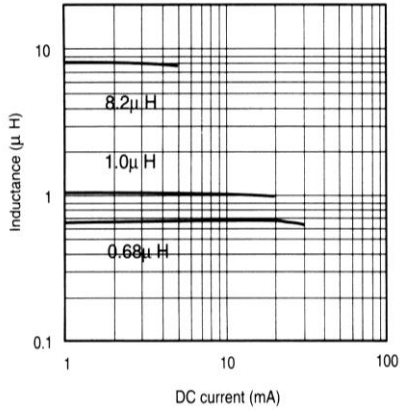

Inductance vs. Temperature Characteristics

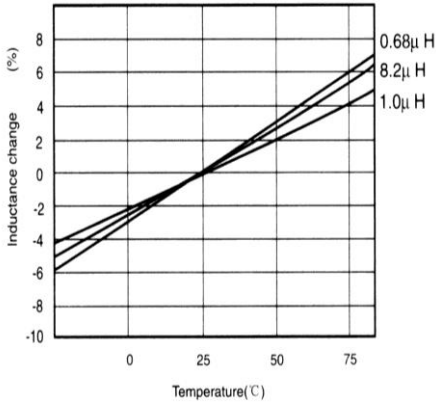

Q vs. Frequency Characteristics

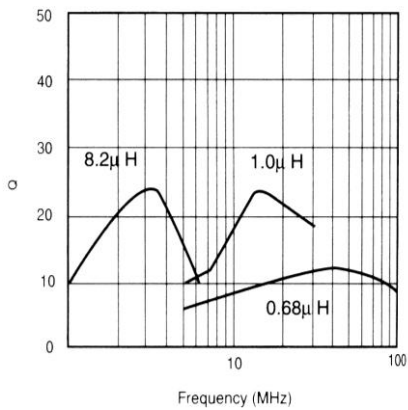

SDFL2012 Series

Inductance vs. DC Current Characteristics

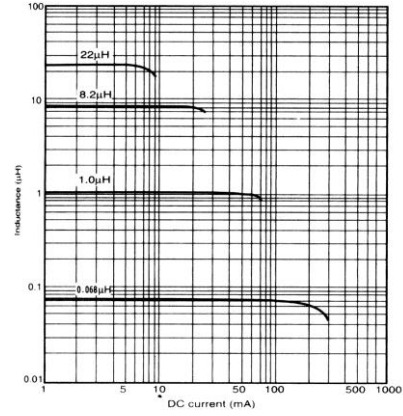
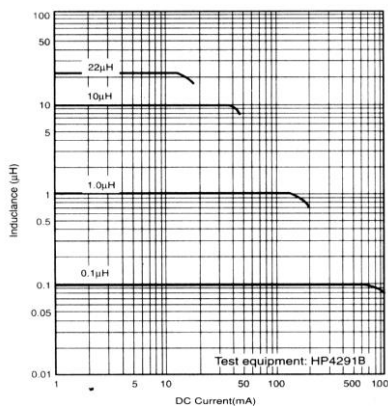

Inductance vs. Temperature Characteristics

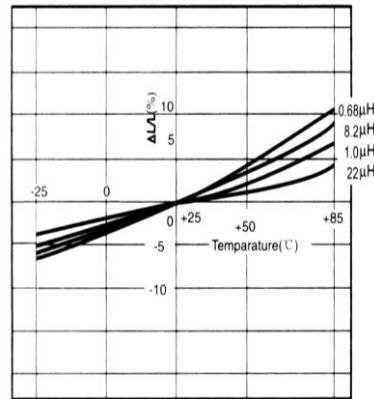

Q vs. Frequency Characteristics

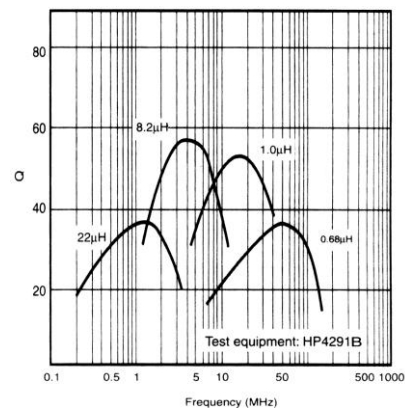

SDFL3216 Series

Inductance vs. DC Current Characteristics

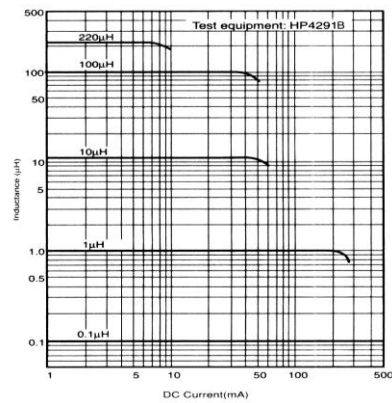

SDFL2012 Series

Inductance vs. Temperature Characteristics

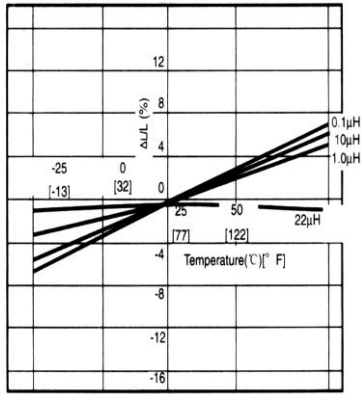

SDFL3216 Series

Inductance vs. Temperature Characteristics

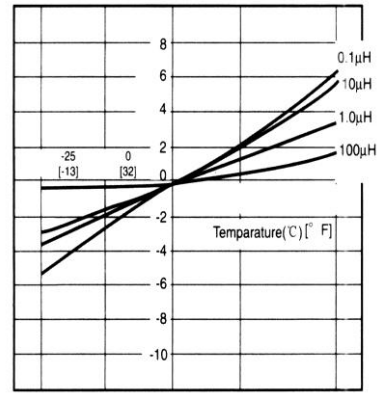

Q vs. Frequency Characteristics

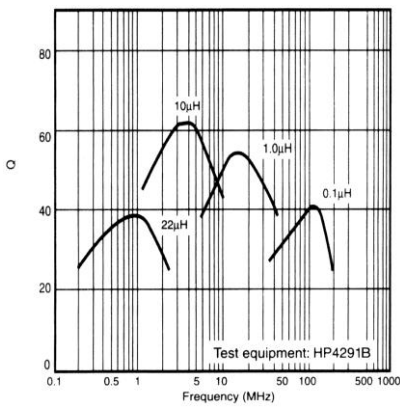

Q vs. Frequency Characteristics

