



Comair Rotron *Fans, Blowers & Impellers*

- Since 1947 -



www.ComairRotron.com

Comair Rotron is recognized as a premier global provider of air-moving and thermal solutions with the leading fan technology.

Its main products are fans, fan trays, fan parts and peripheral devices which are supplied to the telecommunications, automotive, IT, industrial control, air conditioning, HVAC equipment, military, aerospace and electrical equipment industries as well as customized solutions for medical and safety system. And Comair Rotron PAPR respiratory systems is widely used in Industrial and Medical area.

Introduction

www.ComairRotron.com

- Since 1947 -



Fans, Blowers & Impellers

Application Engineering Information	Page
Application Engineering Information	2
Enviro-Shield	11
Tachometer Output Option	12
ThermaPro-V™ Technology	13
Programmable Technology	14
DC Fan Performance Sensor (FPS)	16
AC Fan Performance Sensor (FPS)	18
E3 Protection	56
Nomenclature Guide	57

Model	Size (mm)	Page
DC Fans		
CR4028	40 × 28	20
CR6025	60 × 25	21
CR8025	80 × 25	22
Sprint DC	80 × 32	23
Sprite DC	80 × 42	24
Muffin DC	120 × 32	25
Muffin XP DC	120 × 38	26
Whisper XL DC	120 × 39	27
Muffin XL DC	120 × 39	28
Galaxy DC	127 × 38	29
Major DC	172 × 150 × 51	30
Patriot DC	172 × 51	31
Maltese DC	172 × 150 × 55	32
Tarzan DC	176 × 107	33
Caravel DC	254 × 89	34

Model	Size (mm)	Page
Mixflow		
Mixtus 6.8 DC	172 × 51	35
Mixtus 7.9 DC	220 × 70	36
Motorized Impeller		
Diplomat DD4021	118 × 55	37
Diplomat DD6921	175 × 53	38
Diplomat DD6927	175 × 69	39
Diplomat DD8928	227 × 71	40
Diplomat DD8939	227 × 99	41
Diplomat DDE1149	281 × 125	42

Model	Size (mm)	Page
DC Blower		
Whiffet DC	80 × 32	43
Biscuit DC	121 × 31	44
Spinnaker DC	161 × 51	45

Model	Size (mm)	Page
AC Fans		
Sprite AC	80 × 42	46
Muffin XL AC	120 × 39	47
Major AC	172 × 150 × 51	48
Patriot AC	172 × 51	49
Maltese AC	172 × 150 × 55	50
Tarzan AC	176 × 107	51
Caravel AC	254 × 89	52
Caravel XL AC	254 × 107	53

Model	Size (mm)	Page
Military Grade Fan		
Galaxy DC Digital	127 × 38	54
Patriot DC Digital	172 × 51	55

“Air moving solutions made simple”

www.ComairRotron.com

Application Engineering Information

Introduction: Convection Cooling

Of the many ways to dissipate heat in electronic components, forced convection cooling is the most effective. These Engineering notes will discuss several areas of importance in determining the correct fan or blower for any specific application.

Once the decision is made to use forced convection cooling, several points must be considered before a fan can be specified. Forced convection heat transfer can be effected in two ways: evacuation or pressurization of the cabinet. When evacuating a cabinet (fan on the exhaust side), the air distribution inside the cabinet is flexible. Cooling ports can be placed at any position in the cabinet to insure proper cooling in desired locations. Heat from the fan itself is not dissipated into the cabinet. However, filtering the fan on the exhaust side is extremely difficult.

Pressurizing the cabinet is the preferred method, since incoming air can be readily filtered. With the cabinet under pressure, any cracks or crevices will have a small amount of leakage from the cabinet and dust will not seep in. The fan is handling cooler, denser air, and it will have a slightly higher pressure capability. Fan life and reliability are increased because the fan ambient temperature is lower. The disadvantage of pressurization is that heat generated by the fan is dissipated into the cabinet.

Cabinet Cooling Hints

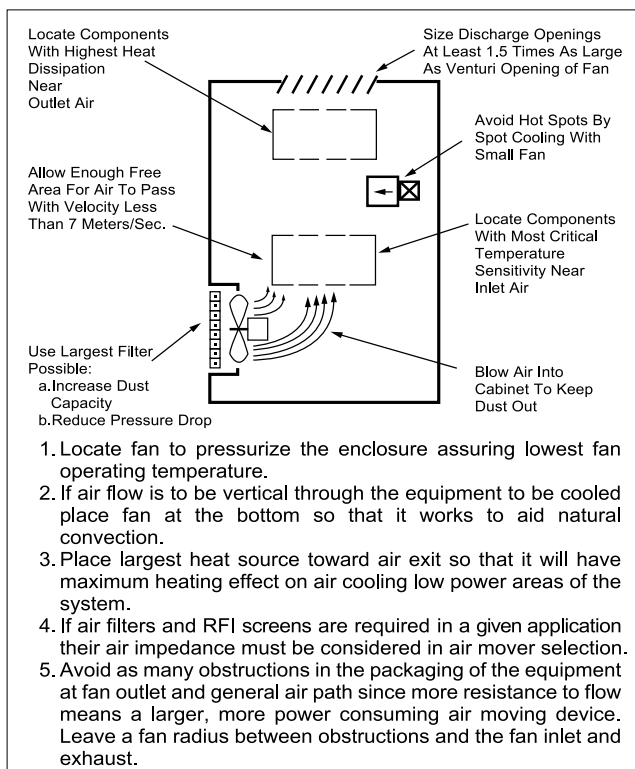

Figure 1

Figure 1 gives some cabinet cooling hints, using pressurization. These should be followed in system design to obtain the most effective cooling.

Establishing Cooling Requirements

Before a fan can be specified, the airflow required to dissipate the heat generated has to be approximated. Both the amount of heat to be dissipated and the density of the air must be known. The basic heat transfer equation is:

$$q = C_p \times W \times \Delta T$$

where q = amount of heat transferred

C_p = specific heat of air

ΔT = temperature rise within the cabinet

W = mass flow

Mass flow is defined as:

$$W = \text{CFM} \times \text{Density}$$

By incorporating conversion factors and specific heat and density for sea level air, the heat dissipation equation is arrived at:

$$\text{CFM} = 3160 \times \text{Kilowatts}/\Delta T \text{ } ^\circ\text{F}$$

This yields a rough estimate of the airflow needed to dissipate a given amount of heat at sea level. It should be noted that the mass of air, not its volume, governs the amount of cooling.

Determining System Impedance

After the airflow has been determined, the amount of resistance to it must be found. This resistance to flow is referred to as system impedance and is expressed in static pressure as a function of flow in CFM. A typical system impedance curve, in most electronic equipment, follows what is called the "square law", which means that static pressure changes as a square function of changes in the CFM. Figure 2 describes typical impedance curves. For most forced air cooling applications, let $n=2$; approximating a turbulent system.

Static pressure through complex systems cannot be easily arrived at by calculation. In any system, measurement of the

Typical Impedance Curves

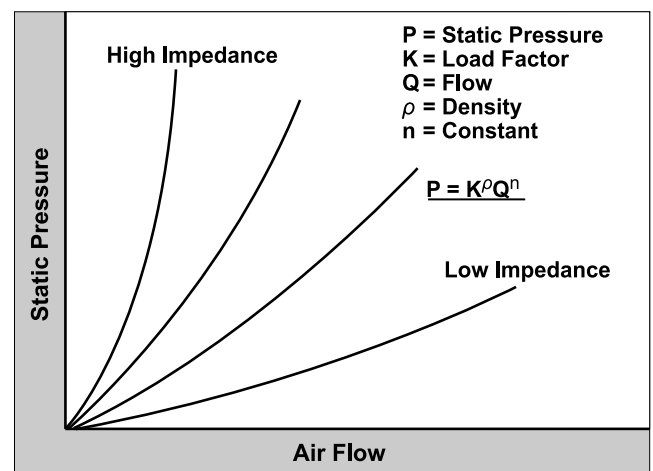

Figure 2

static pressure will provide the most accurate result. Comair Rotron makes this type of testing available. Please contact Application Engineering for more information.

System Flow

Once the volume of air and the static pressure of the system to be cooled are known, it is possible to specify a fan. The governing principle in fan selection is that any given fan can only deliver one flow at one pressure in a given system.

Fan/System Interaction

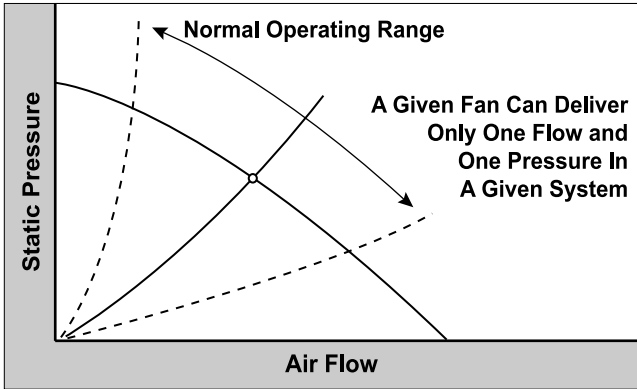

Figure 3

Figure 3 shows a typical fan pressure versus flow curve along with what is considered the normal operating range of the fan. The fan, in any given system, can only deliver as much air as the system will pass for a given pressure. Thus, before increasing the number of fans in a system, or attempting to increase the air volume using a larger fan, the system should be analyzed for possible reduction in the overall resistance to airflow. Other considerations, such as available space and power, noise, reliability and operating environment should also be brought to bear on fan choice.

Impact of Different System Impedances

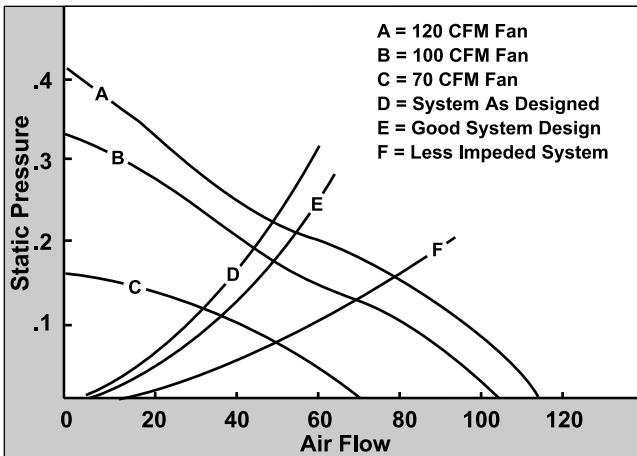

Figure 4

To demonstrate the impact of system resistance on fan performance, Figure 4 shows three typical fans used in the computer industry. A is a 120 CFM fan, B is a 100 CFM fan and C is a 70 CFM fan. Line D represents a system impedance within a given designed system. If 50 CFM of air are needed, fan A will meet the need. However, fan A is a high performance, higher noise fan that will likely draw more power and be more costly. If the system impedance could be improved to curve E, then

fan B would meet the 50 CFM requirement, with a probable reduction in cost, noise and power draw. And if the system impedance could be optimized to where curve F were representative, then fan C would meet the airflow requirement, at a dramatically lower power, noise and cost level. This would be considered a well-designed system from a forced convection cooling viewpoint. Keeping in mind that a given fan can only deliver a single airflow at a given system impedances, the importance of system design on fan selection becomes obvious. Comair Rotron urges engineers to design fans into their systems, rather than add them as an afterthought, for best performance, noise, power and cost characteristics.

Series and Parallel Operation

Combining fans in series or parallel can achieve the desired airflow without greatly increasing the system package size or fan diameter. Parallel operation is defined as having two or more fans blowing together side by side. The performance of two fans in parallel will result in doubling the volume flow, but only at free delivery. As Figure 5 shows, when a system curve is overlaid on the parallel performance curves, the higher the system resistance, the less increase in flow results with parallel fan operation. Thus, this type of application should only be used when the fans can operate in a low impedance near free delivery.

Series Vs. Parallel Performance

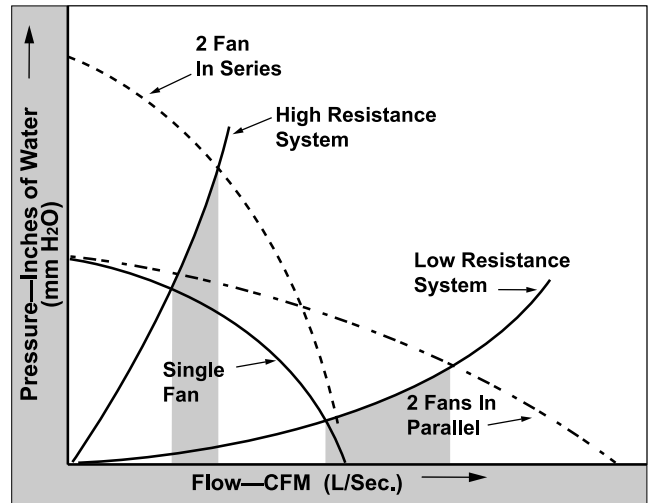

Figure 5

Series operation can be defined as using multiple fans in a push-pull arrangement. By staging two fans in series, the static pressure capability at a given airflow can be increased, but again, not to double at every flow point, as Figure 5 displays. In series operation, the best results are achieved in systems with high impedance.

In both series and parallel operation, particularly with multiple fans (5,6,7,etc), certain areas of the combined performance curve will be unstable and should be avoided. This instability is unpredictable and is a function of the fan and motor construction and the operating point. For multiple fan installations, Comair Rotron strongly recommends laboratory testing of the system.

Application Engineering Information

Speed and Density Changes

By using dimensional analysis and fluid dynamic equations, basic fan laws can be derived giving a relationship between airflow, static pressure, horsepower, speed, density and noise. Figure 6 shows the most useful of these fan Laws.

Basic Fan Laws		
Variable	When Speed Changes	When Density Changes
Air Flow	Varies directly with speed ratio $CFM_2 = CFM_1 \left(\frac{RPM_2}{RPM_1} \right)$	$CFM_2 = CFM_1 \left(\frac{\rho_2}{\rho_1} \right)$
Pressure	Varies with square at speed ratio $P_2 = P_1 \left(\frac{RPM_2}{RPM_1} \right)^2$	Varies directly with density ratio $P_2 = P_1 \left(\frac{\rho_2}{\rho_1} \right)$
Power	Varies with cube of speed ratio $HP_2 = HP_1 \left(\frac{RPM_2}{RPM_1} \right)^3$	Varies directly with density ratio $HP_2 = HP_1 \left(\frac{\rho_2}{\rho_1} \right)$
Noise	$N_2 = N_1 + 50 \log_{10} \left(\frac{RPM_2}{RPM_1} \right)$	$N_2 = N_1 + 20 \log_{10} \left(\frac{\rho_2}{\rho_1} \right)$

Figure 6

As an example of the interaction of the fan laws, assume we want to increase airflow out of a fan by 10%. By increasing the fan speed 10%, we will achieve the increased airflow. However, this will require 33% more horsepower from the fan motor. Usually, the fan motor is being fully used and has no extra horsepower capability. Other answers will have to be considered. The fan laws can be extremely useful in predicting the effects on fan performance and specification when certain operating parameters are changed.

Effect of Density on Fan Performance (Speed Constant)

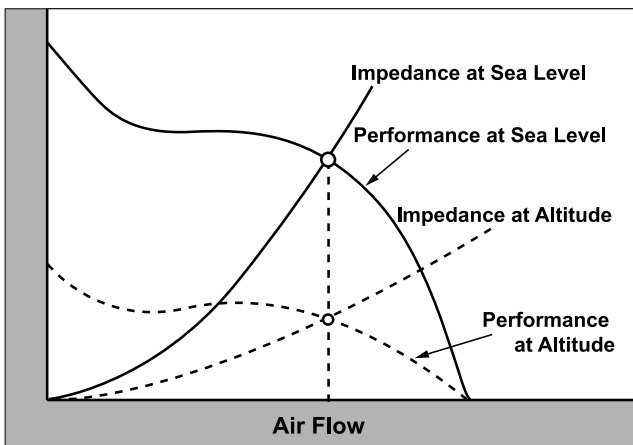

Figure 7

Since a fan is a constant volume machine, it will move the same CFM of air no matter what the density of the air as seen in Figure 7. However, a fan is not a constant mass flow machine. Therefore, mass flow changes as the density changes. This becomes important when equipment must operate at various altitudes. The mass flow is directly proportional to density change, while the volume flow (CFM) remains constant. As air density decreases, mass flow decreases and the effective cooling will diminish proportionately. Therefore, equivalent mass flow is needed for equivalent cooling, or the volume flow (CFM) required at altitude (low density) will be greater than what required at sea level to obtain equivalent heat dissipation.

Acoustic Noise

Noise is, to a great extent, a purely subjective personal phenomenon. Perhaps the best definition of it is as an unwanted sound. Noise does, however, have two basic characteristics. The first is the physical phenomenon which can be measured and thus used in technical specification. The second is the psychoacoustical characteristic which attempts to judge the effect of noise on human beings. In industries that use small cooling fans, fan noise simply interferes with the ability of the people working nearby to concentrate on their work. The factors of greatest importance to the system designer are the psychological influences on the person rather than the physical influences of sound on the human ear.

Sound is perceived and measured as minute pressure fluctuations above and below the ambient pressure. The pressure variations of interest for their psychoacoustical effect vary as much as 13 orders of magnitude. Because of this large range of hearing capability, it is convenient to express these values in decibels. Sound Pressure Level (SPL) which is environmentally dependent, is defined as:

$$SPL = 20 \log_{10} (P / P_{ref})$$

where p = pressure
P_{ref} = a reference pressure

In defining the noise generated by a fan, it is best to define the noise emanating from the source. This is called the Sound Power Level and is independent of the environment. Sound Power Level is defined similarly to sound pressure on a logarithmic scale as:

$$PWL = 10 \log_{10} (W / W_{ref})$$

where W = acoustic power of the source
W_{ref} = an acoustic reference power

Sound Power Level cannot be measured directly and must be calculated from sound pressure measurements. Sound Power Level, since it is a measurement of noise unaffected by such factors as the fan's distance from the hearer, is used as the basic measurement for comparing noise levels of fans, as well as noise levels at different operating points of the same fan. In practice, another property of noise, its frequency, is also considered. For fans, two types of noise related to frequency are important: wide band noise, in which acoustic energy is continuously distributed over a frequency spectrum; and pure tones, in which the acoustic energy is concentrated over narrow bands in the frequency spectrum.

Since fan noise is predominantly wide band in nature with some pure tones, it is convenient to divide the audible frequency range into bands and to plot the average Sound Power Level in each band. For specification and rating purposes, it is generally acceptable to divide the audible frequency spectrum into eight octave bands, each with an upper limit twice that of the lower limit. These bands are usually designated by their center frequency. Fan noise data is usually plotted as Sound Power Level against the octave frequency bands.

Noise Rating Systems

Comair Rotron uses four rating methods for describing the noise levels in the fans it manufactures.

The data sheets on each fan in this catalog contain noise rating in all four systems.

PSIL

The first system used is Preferred Speech Interference Level. The PSIL is determined as the arithmetic average of the sound pressure level in the three octave bands with center frequencies of 500, 1000 and 2000 Hz. This rating is a good guide to the effect of noise on spoken communications.

dBA

A second rating system is the "A" weighted sound pressure level (dBA) often used by government agencies in determining compliance with such regulations as the Occupational Safety and Health Act (OSHA). The dBA rating is determined directly by a sound level meter equipped with a filtering system which de-emphasizes both the low and high frequency portions of the audible spectrum. This measurement is recorded at a distance of 3 feet from the source.

NPEL

A third rating system is the "A" weighted sound power level referenced to a 1 picowatt and expressed in Bels. This is also referred to as the Noise Power Emission Level (NPEL). NPEL was adopted by the Institute of Noise Control Engineering (INCE) as the preferred unit of measure. The INCE "Recommended Practice for Measurement of Noise Emitted by Air Moving Devices (AMDs) for Computer and Business Equipment" is a guideline for the description and control of noise emitted by components. ANSI S 12.11 now includes the procedures called for in the INCE Practice. This is the latest and most technically thorough acoustic test procedure available. Comair Rotron does all acoustical testing per INCE and ANSI S12.11-1987.

Freely Suspended

The fourth rating system used is a method known as Freely Suspended. In this method a fan is suspended from springs in the middle of a Calibrated Reverberant Room. The fan is run at nominal voltage, free delivery, and at a distance of 1 meter. The sound pressure level (dBA) is recorded. (For comparison dBA @ 1meter + .7778 = dBA @ 3 feet).

Causes of Fan Noise

Since noise in most measuring systems is specified in decibels (DB), it is useful to see how DB changes relate to perceived loudness:

DB Change Apparent Change in Loudness

- 3 DB Just noticeable
- 5 DB Clearly noticeable
- 10 DB Twice (or half) as loud

Noise emanating from axial fans is a function of many variables and causes:

Vortex Shedding

This is a broad band noise source generated by air separation from the blade surface and trailing edge. It can be controlled somewhat by good blade profile design, proper pitch angle and notched or serrated trailing blade edges.

Turbulence

Turbulence is created in the airflow stream itself. It contributes to broad band noise. Inlet and outlet disturbances, sharp edges and bends will cause increased turbulence and noise.

Speed

The effect of speed on noise can best be seen through one of the fan laws:

$$DB_1 = DB_2 + 50 \log_{10} (rpm_1 / rpm_2)$$

Speed is a major contributor to fan noise. For instance, if the speed of a fan is reduced by 20%, the DB level will be reduced by 5 DB.

Fan Load

Noise varies as the system load varies. This variation is unpredictable and fan dependent. However, fans are generally quieter when operated near their peak efficiency.

Structure Vibration

This can be caused by the components and mechanisms within the fan, such as residual unbalance, bearings, rotor to stator eccentricity and motor mounting. Motor mounting noise is difficult to define. It should be remembered that cooling fans are basically motors and should be treated as such when mounted.

System Effects on Fan Noise

System disturbances are the biggest causes of fan noise. When a fan is designed for low noise operation, it can be very sensitive to inlet and outlet disturbances caused by card guides, brackets, capacitors, transformers, cables, finger guards, filter assemblies, walls or panels, etc.

When placing a fan in an electronic package, great care should be taken in locating components. Trial and error will be needed to determine the system's effect on noise. Different fan types will react differently in the same system. Common sense and intuition play a large role in the fan/system design.

For instance, if it is necessary to place card guides against the face of the fan for card cooling, the fan may develop a large pure tone if it is done on the inlet side; on the discharge side, the effect may be much less.

Figure 8 illustrates how one system component, finger guards, can effect noise.

Impact of Finger Guard on Noise

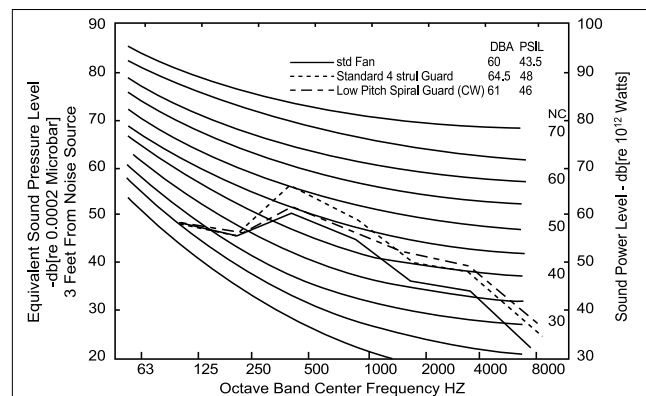

Figure 8

Application Engineering Information

Guidelines for Low Noise

The following guidelines will aid the fan user in minimizing fan noise.

System Impedance

This should be reduced to the lowest possible level so that the least noise for the most airflow is obtained. The inlet and outlet ports of a cabinet can make up to between 60 and 80% of the total system impedance, which is much too high for a low-noise result. And, if a large part of the fan's flow potential is used up by the impedance of the inlet and outlet, a larger, faster and noisier fan will be required to provide the necessary cooling.

Flow Disturbance

Obstructions to the airflow must be avoided whenever possible, especially in the critical inlet and outlet areas. When turbulent air enters the fan, noise is generated, usually in discrete tone form, that can be as much as 10 DB higher and thus cause considerable annoyance.

Fan Speed and Size

Most Comair Rotron fans have several low speed versions. These should be tried and used whenever possible. Various fan sizes should also be explored; quite often a larger, slower fan will be quieter than a smaller, faster fan delivering the same airflow.

Temperature Rise

Airflow is inversely proportional to allowable temperature rise within the system. Therefore, the ΔT limit placed on a piece of equipment will dictate to a large extent the required flow, and therefore, noise. If the temperature limit can be relaxed even a small amount, a noise reduction may result.

Vibration Isolation

In certain instances, the fan must be isolated from the cabinet to avoid vibration transmission. Because fans operate at a low frequency, and are light in weight, vibration isolators must be soft and flexible. Since the transmission is dependent on the system, trial and error is the best approach to a quiet system/fan interaction. In systems that require 20 CFM or less, noise radiated by the cabinet is the predominant noise. Isolation of the fan is the only practical solution to this type of system noise problem.

Brushless DC

Brushless DC fans are usually available at three nominal voltages: 12V, 24V and 48V. If the system has regulated power supply in one of these, then a brushless DC fan may be selected which will give the exact performance required, regardless of the AC input variables which plague AC fans.

Because the speed and airflow of a typical DC fan is proportional to the voltage supplied, a single product may be used to meet different applications by setting the supply voltage to what will give the desired airflow.

Figure 9 describes the result of varying the DC voltage supplied to a given fan. If, for example, a fan supplies 110 CFM of air at free delivery, 28V may yield 127 CFM, should that be needed. On the other hand, 24V operation may provide too much flow; the supply voltage might then be reduced to a level that yields the desired airflow.

Results of Varying Voltage to Typical DC Fans

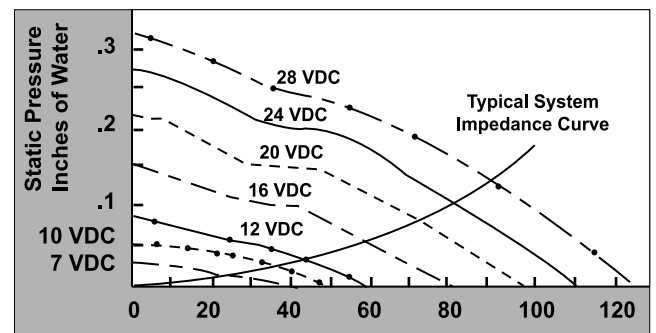

Figure 9

The voltage range that may be applied to the fan to assure satisfactory operation is dependent upon the individual fan design and may be as small as 10-14V for 12V units and up to 12-56V for 48V units.

Current

Brushless DC fans do not draw constant currents. The choice of the power source along with the addition of other peripheral devices will be affected by the type and number of DC fans and their motor current characteristics. Throughout the rotational cycle and particularly at commutation, the currents will fluctuate from minimum to maximum.

The waveform and level of ripple current will vary significantly between fans and motor designs, making specification in narrow terms difficult. An understanding of the power source limitations and how they may be impacted by various brushless DC fans early in the design phase will help prevent problems and allow maximum system flexibility.

Current ripple may be analyzed by waveform measurements using a laboratory-quality oscilloscope and a suitable series resistance (R1), typically 1 ohm. Note that the current excursions vary from a minimum of 20 mA to a maximum approaching 800 mA while the motor is in a running condition. See Figure 10.

Measuring Running Current

The use of a lab-quality digital multimeter to measure the DC running current will present a small error due to the AC ripple component of the DC motor. While the measured DC current value is an acceptable indicator of running motor current, a more precise method of running current measurement would be to measure the current's true root mean square (TRMS), i.e., to measure both the AC and DC current components. For example:

$$\text{TRMS} = \sqrt{\text{DC}^2 + \text{AC}^2}$$

Peak Starting Current

The peak in-rush/peak starting current of a brushless DC fan typically will be a function of circuit resistance and power resource. However, many brushless DC fans incorporate additional filter capacitance for electromagnetic interference (EMI) suppression. Depending on the circuit location, the capacitance may represent a very high instantaneous in-rush current spike. Figure 11 represents the effect of a 47 μ f aluminum electrolytic capacitor across the input of a brushless DC fan.

Current Waveshapes

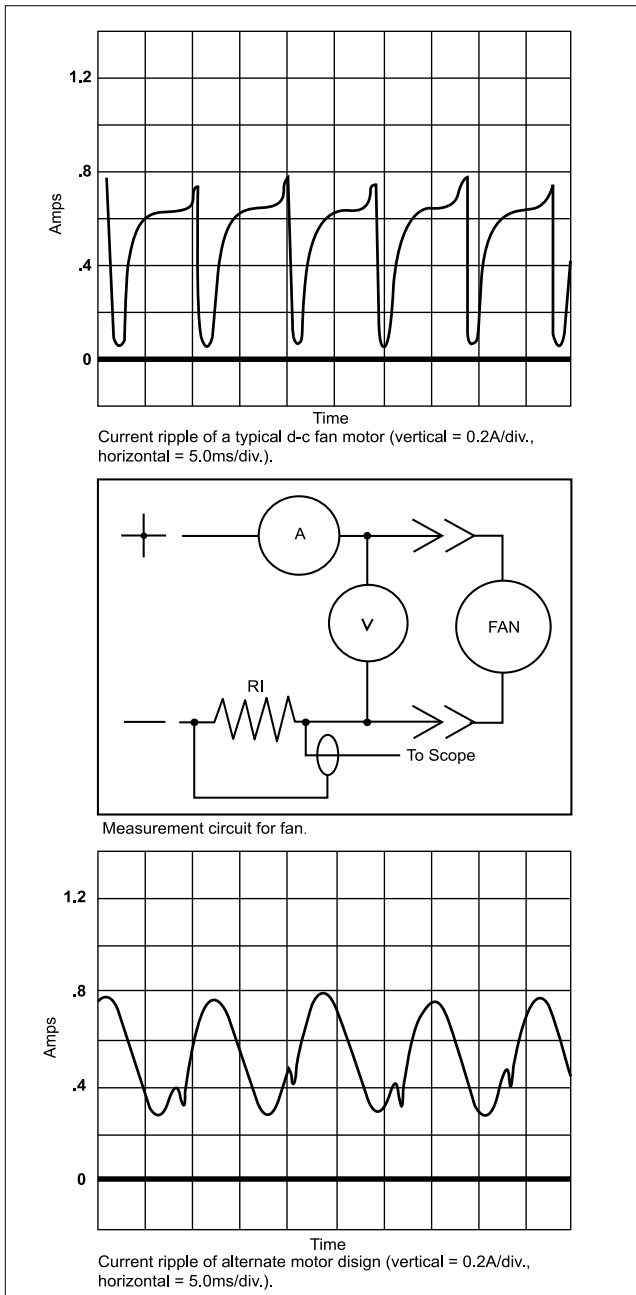

Figure 10

Measuring the peak starting current of brushless DC fan requires that the motor stator be at ambient room temperature prior to the application of power, the rated operative voltage selected and the storage oscilloscope set to trigger on the leading edge of the current waveform using the test circuit shown earlier. Figure 12 illustrates the peak starting currents upon application of power to the brushless DC fan in Figure 11, less the 47 μf filter capacitor. The peak currents are one-quarter of Figure 11.

Current Limiting

The power supply limitations must be considered when DC fans are used. Many power supplies incorporate current

Typical Peak Starting Current

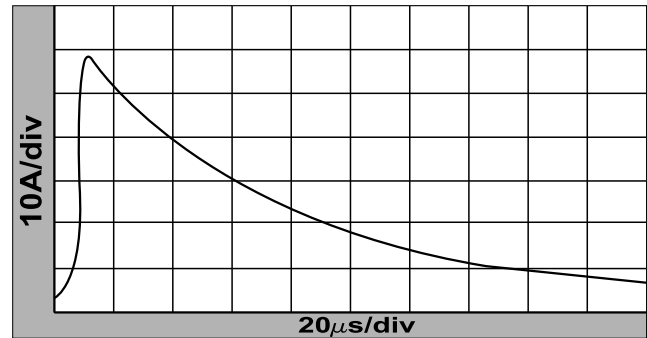

Figure 11

limiting, current fold-back, or current shutdown protection circuits. Knowing the peak starting currents and maximum ripple currents during motor operation is essential in determining the power supply reserves necessary to maintain other peripherals which may be sharing the same power bus, and to avoid nuisance problems associated with

Typical Peak Starting Current Less Capacitor

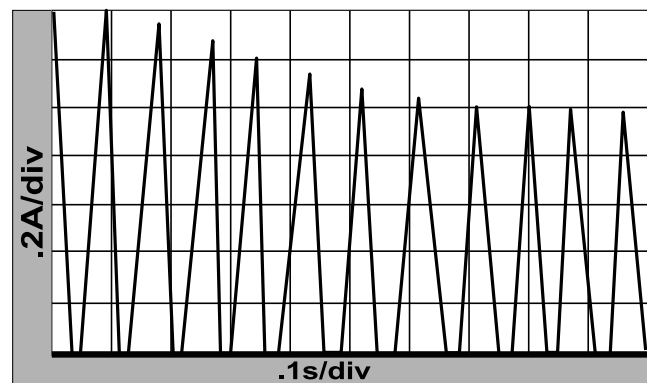

Figure 12

the power supply protection circuitry. Depending on the size and design of brushless DC fan motors, the ratio of peak starting current to running current can be quite large, e.g., 4:1 or 5:1. To overcome the stress that would be placed on the power supply, many brushless DC motors incorporate a form of current limit, usually linear or pulse width modulated (PWM). With current limiting, peak current draw typically will be limited to values of 2.5 to 1 or less, as shown in Figure 13. The limiting of current to the brushless DC fan

Typical Peak Starting Current with Current Limitor

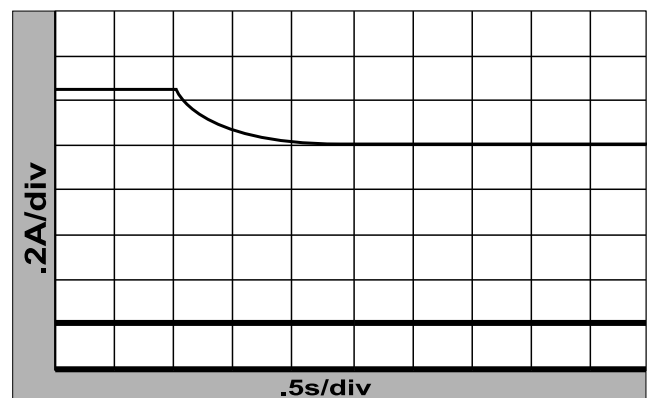

Figure 13

Application Engineering Information

motor will also limit the starting torque of the motor, which will extend the time needed for the fan to reach full speed. Since DC fans have much higher starting torques than their AC counterparts, the time to reach full speed with the use of current limit will be less than equivalent AC models.

When operating more than one fan on the same power bus, the imposed ripple current can become significantly more complex as the currents of each fan add and subtract with each other. Figure 14 illustrates the running current of three fans sharing the same power bus. Under certain operating conditions, this complex ripple current could pose a potential for interference within the system. Bus isolation filtering may be required to assure adequate buffering.

Current Ripple Wave Form of Multiple Fans

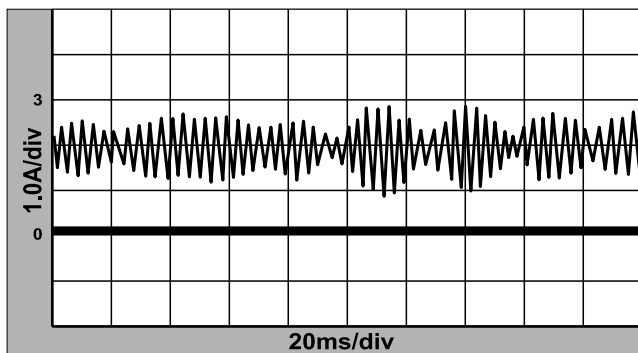

Figure 14

Ripple Current

In brushless DC fans, ripple current is a function of the motor design, electronic switching circuitry, operating voltage and current. The motor does not represent a constant load and may vary considerably from IAVG, as seen in Figure 15.

Typical Ripple Current

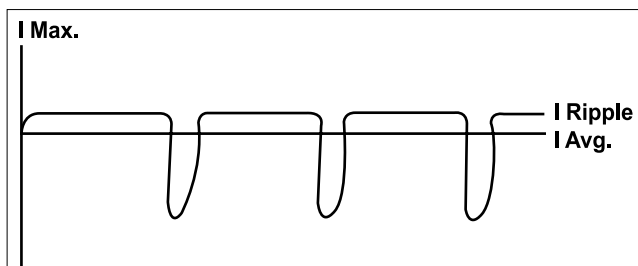

Figure 15

Figure 16 describes various methods of dealing with motor ripple current.

EMI

Identifying the offending interference problem in a system can be difficult. To help in establishing a common language as a basis for understanding interference problems, a discussion of the effects of different types of interference and the possible methods of controlling them follows.

Electromagnetic Interference (EMI) sometimes seems to be the general catch-all term. In fact, it is a generic term for

Methods of Dealing with Motor Ripple Current

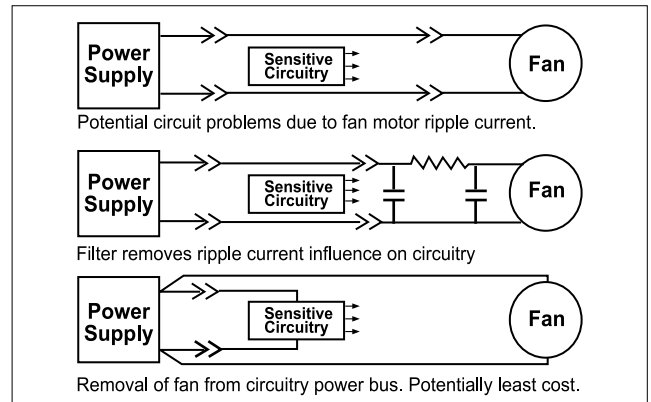

Figure 16

unwanted interference energies conducted as currents or radiated as electromagnetic fields. Radio frequency interference (RFI) is the older term used interchangeably in particular by the regulatory agencies.

The Federal Communications Commission (FCC) and other agencies, such as Germany's Verband Deutscher Elektrotechniker (VDE) have established rules governing EMI emissions.

The FCC Part 15 Subpart J (Docket 20780) deals with electronic data processing equipment, and applies to devices that generate pulse rates in excess of 10,000 pulses per second and use digital techniques. Equipment covered under Subpart J is broken down into two classes:

- Class A—Covers computing devices used in commercial and industrial and business applications.
- Class B—Applies to computing devices used in a residential environment.

As Figure 17 demonstrates Class B limits are much more stringent, requiring additional design effort to assure compliance. Every component and subsystem must be carefully scrutinized ahead of time to assure that the goals will be met.

Conducted EMI Analysis of a Typical DC Fan

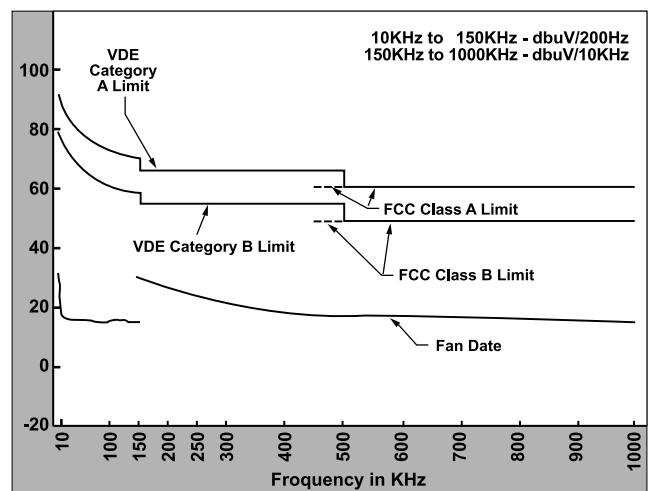

Figure 17

The main design goal is to meet and, if possible, reduce emissions well below Class B, provided costs are within tolerable limits. Frequently, careful design and layout will yield these results at no extra cost.

EMI currents in the fan power leads are referred to as conducted EMI and are usually more of a problem than radiated EMI. In fact, when dealing with brushless DC fans, conducted EMI is normally the only concern. Differential mode EMI is conducted on the power leads of the fan from the power switching transistors used for switching the motor windings.

Radiated EMI is generated by voltages and currents within the circuitry. If not properly suppressed or shielded, it may then be radiated by cables or structures which act as antennae.

The FCC has placed limits on conducted EMI on power lines from 45 MHz through 30 MHz.

Equipment to measure and establish compliance is expensive and verification of compliance is best accomplished by outside facilities specializing in EMI and EMC testing. The engineer can get a fairly good idea of how well the EMI is suppressed in the fan by analyzing the ripple across the power leads with an oscilloscope. See Figure 18.

Typical Current Ripple Comparison

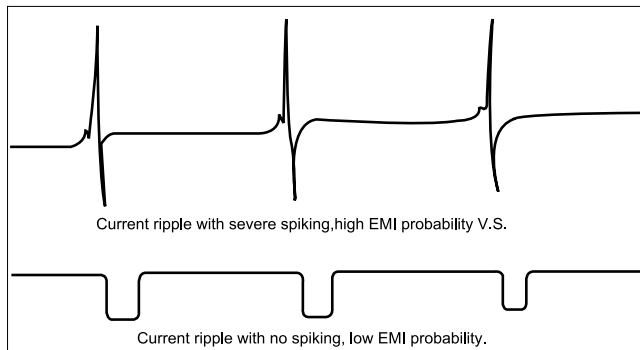

Figure 18

EMC

Electromagnetic compatibility (EMC) can best be described as the ability of equipment to operate without generating unwanted electromagnetic interference that can interfere with the operation of other products, and does not respond to unwanted interference generated elsewhere. If EMC is ignored during the design stages of product development solutions to problems later become expensive and may yield limited results.

While the main desire is to reduce EMI generated by products, it is important to consider the susceptibility of products to EMI based on potential applications.

A good example is the use of a brushless DC fan for cooling a large switching power supply. Although the fan itself may generate EMI, sensitive control circuits, e.g. comparators, within the fan may be swamped by the EMI present in the power supply, resulting in faulty fan operation. For the power supply designer to resolve the problem would require additional filtering and grounding of the fan at additional cost. If resolved at the fan design level, a simple by-pass capacitor or ferrite bead might resolve the problem.

UMF

Uncontained magnetic fields (UMF) refers to the magnetic field of the permanent magnet and stator windings which extends beyond the boundaries of the DC cooling fan. UMF exists in virtually all fans to some degree, but may appear most troublesome in one mounting plane, and nonexistent in another.

To better understand the potential effects of a fan motor within a system, it is necessary to first evaluate the AC magnetic field levels present. In most brushless DC motor designs, the magnetic fields of the permanent magnet and the stator windings are shrouded within a steel housing which offers at least partial shielding (absorption) of the magnetic field, frequently in two of three possible mounting planes. Generally, mounting the fan with the open end of the motor (no steel) away from the sensitive electronic circuits and CRT's will offer the best protection from UMF.

The UMF can directly interface with the CRT presentation, creating distortion or ripple. If the magnetic levels are not strong enough to directly affect the CRT, magnetically induced voltage in sensitive circuitry, pre-amplifiers and operational amplifiers, may generate interference or degradation of the presentation.

Controlling UMF starts with the fan manufacturer. The use of a drawn steel containment can go a long way toward reducing UMF to tolerable levels. Conservative motor designs will also help. From the user's standpoint, placement and location will be critical factors which will prevent costly problems later. In applications where certain confrontations cannot be avoided, the use of high permeability magnetic shielding material may be formed around critical locations to eliminate interference.

Life and Reliability

Comair Rotron conducts a continuous and comprehensive life test program for development purposes as well as for continuous monitoring of production units. The results of the life testing are reflected in continuous improvements in Comair Rotron's products in such critical areas as bearings, lubricants, materials, and insulation systems. The continuous monitoring of production units provides a means of evaluating the adequacy of production methods and quality assurance programs.

Because the primary mode of failure of an air moving device is bearing failure caused by eventual degradation of the lubricant, Comair Rotron has adopted the method of statistical analysis widely used by the bearing industry, known as the Weibull function analysis. The Weibull function analysis method permits a statistically accurate determination of the failure distribution from a small representative sample of air moving devices. Comair Rotron's practice is to accelerate the life testing by operating its products at several elevated temperatures until enough failures of each sample group have been obtained to establish these statistical distributions. These data are then extrapolated to predict the time at which, in a large population, 90% of the air moving devices will still be operative.

Application Engineering Information

This time is referred to as the "L-10" life, or the time at which 10% of the sample could be expected to fail.

Based upon the results obtained at each of the elevated temperatures, (usually 40°C, 55°C and 72°C) a curve may be drawn which will permit the life to be expected at lower temperatures. The curves presented in this catalog have been determined from tests conducted in the manner described here.

Every model fan, regardless of manufacturer, will exhibit different life characteristics depending on the combination of voltage, frequency, ambient temperature, mounting attitude, environment and restriction to airflow conditions it encounters in an individual application. The normal failure mode is in the bearing system and it is usually related to the total temperature the bearing system sees, although other factors may apply.

Generally speaking, there is not much of a life differential between a sleeve bearing system and its equivalent ball bearing system when the total temperature the bearing system sees is relatively low, but as this total temperature increases, ball bearings give progressively longer life than sleeve bearings.

Effect on Fan Noise Due to Damaged Ball Bearing

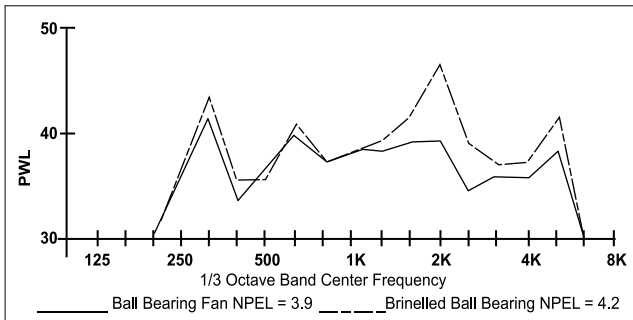

Figure 19

Effect on Fan Noise Versus Life

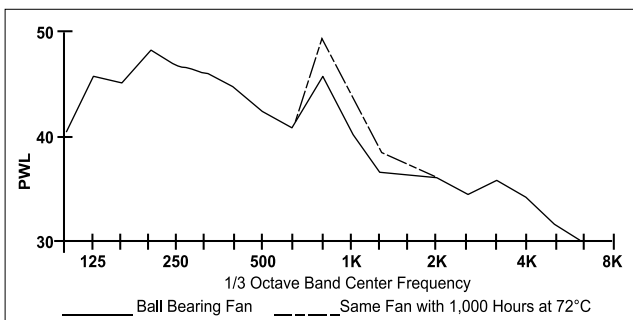

Figure 20

Test Methods

Comair Rotron's Aerodynamic Laboratory is equipped with a testing chamber, illustrated schematically in figure 21. This test chamber is designed to be in accordance with the requirements of figures 4.1 and 52. of Air Moving and Conditioning Association's (AMCA) Standard 210.

The fan under test is mounted on the inlet of the chamber, and flow through the nozzle is varied by the moveable gate assembly. The flow through the calibrated ASME nozzle is determined by measurement of the pressure differential across the nozzle, and simultaneous readings are taken of the static pressure developed by the fan. The function of the auxiliary blower is to provide sufficient pressure drop across the nozzle to allow free delivery flow readings when the static pressure across the fan is zero.

In addition to testing fans, the test chamber may be used for determining impedance of a customer equipment by using the auxiliary blowers to force air through the equipment.

Rotron Test Set up

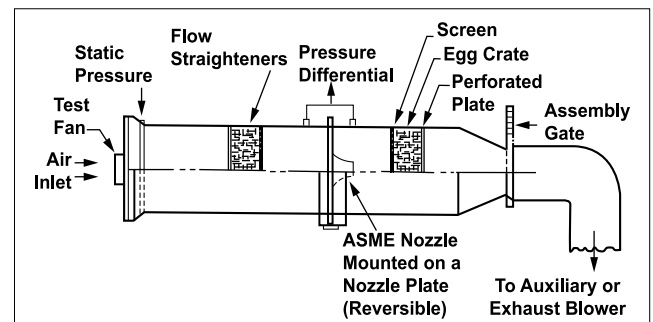

Figure 21

Enviro-Shield

Robust Fans For Harsh Environments

For years, a major problem in the electronic industry has been the deterioration of electrical components from the natural elements such as rain, sleet, and snow. Other conditions such as salt from coastal areas or road salts cause accelerated corrosion on electrical components. Even sulfur dioxide produced from the burning of coal has a major impact on electrical component life. Cooling fans are no exception to this rule.

Comair Rotron, the leader in innovative cooling ideas, has pioneered the way in environmentally protected fans. With the continuous advancements in conformal coating and potting materials, Comair Rotron has researched various chemicals, materials, and processes that provide the greatest degree of protection to our customers. The results have produced our latest value-added product, "Enviro-Shield". The Enviro-Shield protection comes in 3 levels of protection-Type 1, 2, and 3. Each material fully encompasses all electrical components, wires, and circuit paths; ensuring the optimum protection for any condition. These materials can be sprayed, dipped, or injected into the motor assemblies, creating a protective barrier between the delicate electrical components and the outside environments. With Enviro-Shield, cooling fans will meet the most common standards such as NEMA, IP, BELCOR, UL, and ASTM. To verify compliance with these standards, Comair uses a variety of testing apparatus. The most commonly referred to test is the salt fog test. This test demands that the fan be subjected to as many as 14 days of continuous exposure to salt fog environment. Fourteen days is estimated as the equivalent to 10 years of normal outdoor operation. Tests include direct water spraying on the fan, humidity, and dust.

Some discussion can be made over the type of bearing used. Comair has performed numerous tests and has found that the ball bearing systems works exceptionally well. It is not recommended to use sleeve bearings in an environmentally protected fan. The ball bearings are double shielded which resists most contaminants from entering the bearing surfaces.

As a brief outline as to what type of protection is best suited for your needs, consider the following:

- Type 1 protection is intended for environments that include exposure to water mists, sprays, dripping, dust, condensation, and moderate vibrations
- Type 2 protection is intended for harsher environments that include exposure to ocean salts in the form of fog or a mist. Type 2 protection also provides extra protection to the fan for excessive shock and vibration.
- Type 3 protection is also intended for the most severe environments and includes additional protection to the motor windings. Type 3 protection also provides extra protection to the fan for excessive shock and vibration.

Tachometer Output Option

For Speed And Fan Failure Sensing In DC Fans And Blowers

Brushless DC air movers use a commutating sensing circuit for motor operation. An additional Hall Device may be added to the PC board from which digital pulses can be derived and supplied to the design engineer via a third lead referenced to ground. This will allow direct pulse to speed relationships to be derived. These digital pulses can then be conditioned to provide alarms for fan failures such as lights, buzzers, etc.

ISOLATED OR NON-ISOLATED

The standard tachometer output is offered with non-isolated circuitry. The non-isolated tachometer output fan has three leadwires. The power for the tachometer circuit is derived internally from the motor circuit. (See Diagram #1) The isolated tachometer output fan has 5 leadwires. The tachometer circuit is powered separately and therefore isolated from the motor circuit. (See Diagram #2)

Each output is designed around a Hall Device which generates a square-wave output. This output signal must then be conditioned externally by the customer's electronic circuitry to yield a discrete pass or fail signal. The non-isolated tachometer output must be used with the same ground reference as the fan.

NON-ISOLATED TACHOMETER OUTPUT

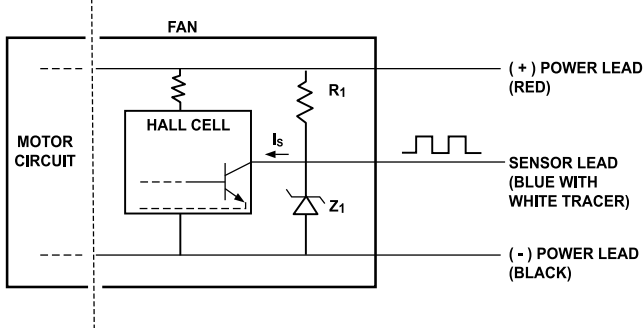

ISOLATED TACHOMETER OUTPUT

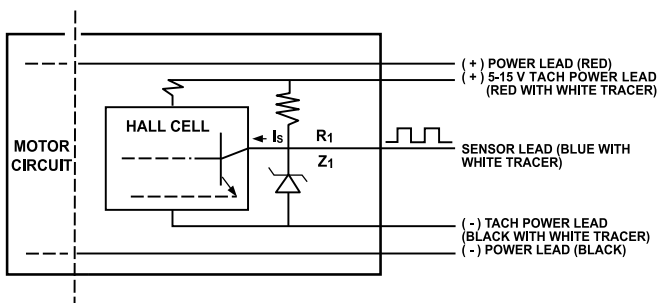

I_s = The sink capability of the collector of the hall Cell = 15 mA maximum. R_1 and Z_1 are added to Tachometer Output fans to produce a fixed amplitude of V_{OUT} .

NOTE: 5V tach out → $R_1 = 10K$
Open Collector → Omit R_1 and Z_1

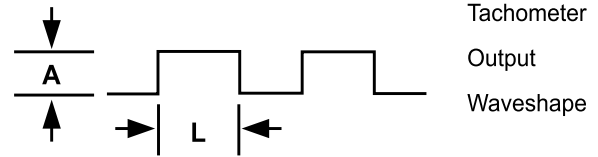

A = Amplitude of Tachometer Output. Fixed amplitude of Tachometer Output, available at any voltage up to input voltage for fan. Contact Comair Rotron Application Engineering Department.

$$L[\text{ms}] = \left(\frac{60,000 \text{ ms}}{\text{RPM of fan}} \right) / 2 \times (\text{Pulses per revolution})$$

DC TACHOMETER OUTPUT

Model	Sensor Circuit Isolation		Output			
	Isolated	Non-Isolated	Open Collector	T.T.L. Compatible (5V Amplitude)	Fixed Voltage	Pulses Per Revolution
Sprint DC	N/A	S	O	S	O	2
Sprite DC	O	S	O	S	O	1
Muffin DC	N/A	S	O	S	O	2
Whisper XL-DC	O	S	O	S	O	1
Muffin XL-DC	O	S	O	S	O	1
Major DC	O	S	O	S	O	2
Patriot DC	O	S	O	S	O	2
Biscuit DC	N/A	S	O	S	O	2
Spinnaker DC	O	S	O	S	O	2
Galaxy DC	N/A	S	O	S	O	2
Whiffet DC	N/A	S	O	S	O	2

S = Standard O = Optional N/A = Not Available

Caution:

On all tachometer models, the output wire must not be applied to either + or - power leads.

OPTO ISOLATED TACHOMETER OUTPUT

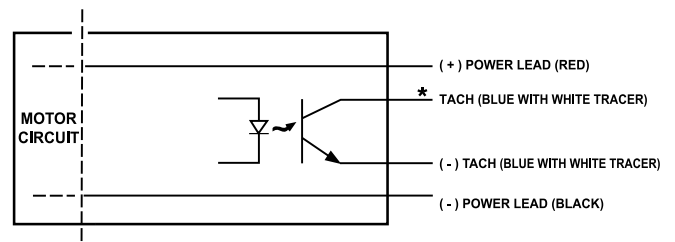

*Require a pull up resistor from isolated circuit

ThermaPro-V™ Technology

Thermal Speed Controlled, Programmable, Voltage Regulated DC Fans & Blowers

At the top of their class.

Give Comair Rotron fans some extra credit. Our unique ThermaPro-V™ circuitry makes them the most precise and versatile airmovers in the industry. To say nothing of how amazingly quiet they are. You can count on TPV to reach your optimal cooling point with minimal noise - without adding on to your system. Now you can design - in Voltage Regulated, Programmable, Thermally Speed Controlled brushless DC fans for completely reliable cooling.

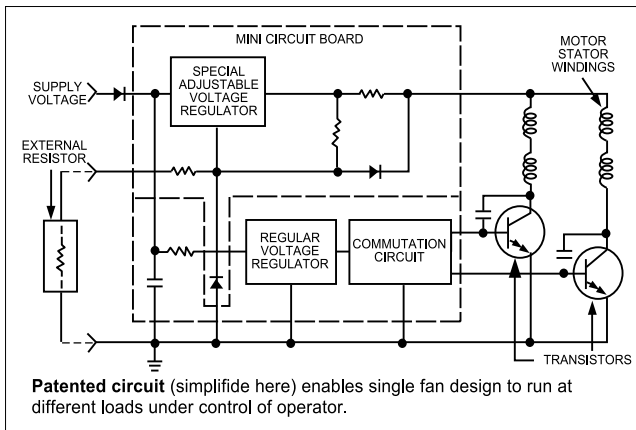

ThermaPro-V capabilities are achieved through the use of a patented circuit design. A small voltage regulator is placed in series with the motor windings. An additional lead from the control leg of the voltage regulator is brought out of the fan to enable the customer to adjust the voltage to the windings and control the speed of the fan.

HOOK UPS

Thermal Speed Control

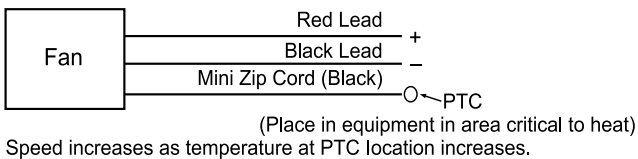

Programmability

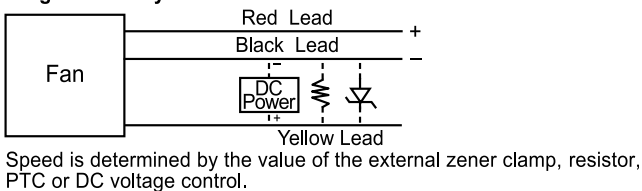

Voltage Regulation

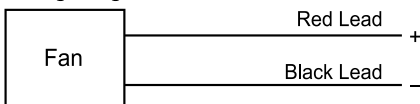

Speed stays constant even though voltage fluctuates.

THERMAL SPEED CONTROL

Advanced degrees are no sweat.

With TPV's closed loop Thermal Speed Control capability, a small thermistor is used to program the fan's voltage regulator to change airflow automatically as a function of temperature. It automatically provides needed cooling in extreme environments and a minimum of noise and power consumption at all times. This results in complete efficiency for your system. And, with two power leads, plus a control and return lead (zip cord) to the PTC thermistor, there's no chance of system shut-down.

Should the sensor fail open, the fan reaches maximum airflow, avoiding any possible damage to sensitive equipment. That means complete reliability for your system.

PROGRAMMABILITY

One right answer to the multiple choice question.

You can now specify a single fan to cover a broad range of airflow needs. TPV programmability lets you easily control the airflow. In fact, it's elementary. External resistors, pulse width modulated signals, zener diodes, thermistor response and other techniques can be used to change fan speed through a single, added control lead wire connected to ground. So forget about expensive circuit redesign or taking the heat from voltage dropping devices. One TPV Programmable fan gives you a vastly extended performance range, simplified system circuitry, reduced specification needs and highly flexible programming options.

VOLTAGE REGULATION

Current events – they're history.

ThermaPro-V solves the problem of power supply voltage fluctuation forever. Internal Voltage Regulation circuitry automatically regulates the input voltage to the motor windings to compensate for any fluctuation caused by a change in the power supply load. With TPV, you always get just the airflow you need – with predictable noise and power levels. And its current limiting circuits keep start-up and locked rotor currents low.

Programmable Technology

Programmable Fans And Blowers

Programmable Fans And Blowers

In 2013 Comair developed an innovated technology, The Programmable Fan. It is a new kind of fan giving the customer the ability to program speed, control method, and output signal. For this new technology there is currently patent pending with the US Patent Office.

What makes these Fans and Blowers unique?

Customers can reprogram the fan to meet their needs. All fans are preprogrammed at Comair to insure functional operation.

On board is a thermal control circuit and a speed control circuit (default), alarm or tach output (default), fan speed version B (default), K, Z, or U allowing the fan to cover several versions commonly covered by different part numbers today.

Since each fan has its own control system, redundant control will insure the system continues to cool despite the potential loss of one of the fans where multiple fans are used.

Comair Major Programmable Fan(JQD)

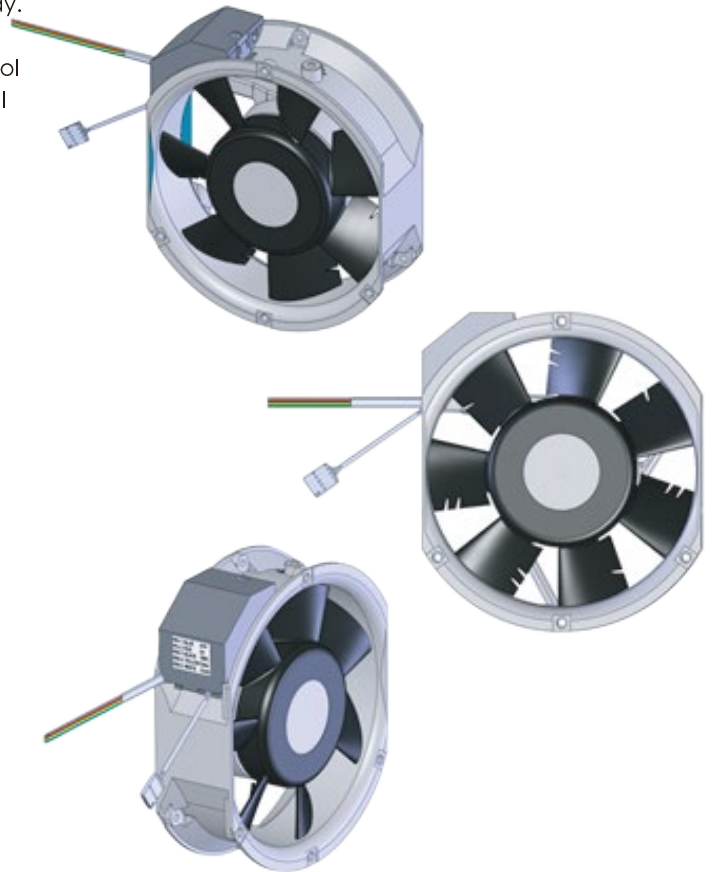

Programmable Technology

Programmable Fans And Blowers

Why Use Programmable Fans And Blowers?

Devices can be upgraded to meet changing thermal, noise, and power consumption demands.

Development time can be reduced to days or weeks instead of months. Moreover, preproduction issues can be eliminated and supply lead times can be reduced drastically.

Benefits of Programmable Fans and Blowers

Programmable fans and blowers offer reduced inventory, flexibility, longer asset life, reduced engineering and production lead times, reduced supply lead times, and ability to service low volume applications cost effectively.

Moreover, it has output signal flexibility as it has 100% tach and alarm capability. It can be easily and quickly switched from one to the other. It also has control method flexibility. The control method from voltage/PMW can be easily and quickly changed to thermal control internal (NTC).

Comair Major Programmable DC Fan (JQD)

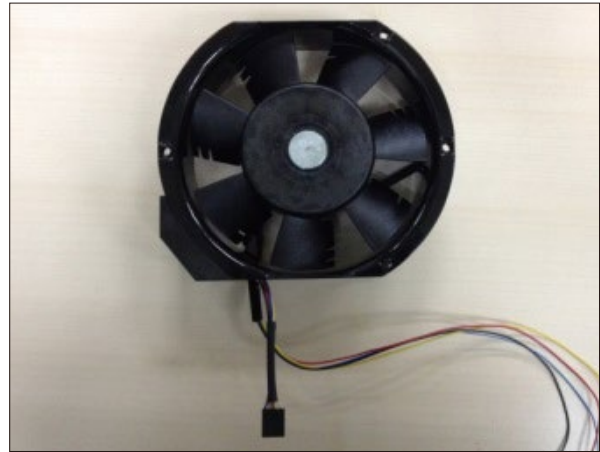

Standard Comair Maltese DC Fan (MTD)



DC Fan Performance Sensor (FPS)

For DC Fans and Blowers

Thermal management of electronic packages is increasingly challenging as package sizes decrease and circuit complexities increase. In order to avoid critical internal temperature increases within the electronic system, it is necessary to make provisions for a continuous supply of cooling airflow by monitoring and remote warning of potential airflow interruption.

Comair Rotron supplies a variety of Fan Performance Sensor-equipped fans which provide both monitoring and remote warning capabilities. Should cooling airflow be reduced or interrupted due to a drop in RPM, these FPS systems allow for backup cooling devices to go on line, or for less critical equipment, for system shutdown in order to avoid excessive internal temperature rise.

ISOLATED OR NON-ISOLATED

In addition to the options listed below, the Fan Performance Sensor is offered with either isolated or non-isolated circuitry. The isolated FPS has three leads (+), (-) and (output), in addition to the two power leads or terminals for the motor circuit, and is therefore electrically isolated from the motor circuit. The nonisolated FPS has only the (output) lead in addition to the motor connections. The (+) and (-) that power the sensor circuit are derived internally from the motor circuit. Each output is designed around a Hall Device, which generates a square-wave output. This output signal is then conditioned internally by additional electronic circuitry to yield a discrete pass or fail signal.

LEADWIRE CONFIGURATION

Isolated 5 Leads	(+) Fan Power	Red
	(-) Fan Ground	Black
	(+) FPS Power	Red w/White Tracer
	(-) FPS Ground	Black w/White tracer
	(Sensor) FPS Sensor	Blue w/White Tracer
Non-Isolated 3 Leads	(+) Fan Power	Red
	(-) Fan Ground	Black
	(Sensor) FPS Sensor	Blue w/White Tracer

NOTE: Terminals may replace the (+) (-) fan power leadwires

TYPICAL FPS APPLICATION EXAMPLE

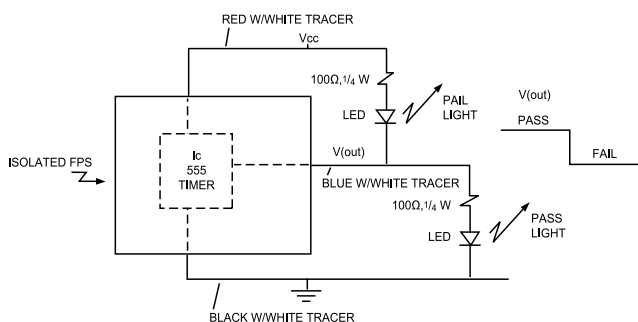

NOMENCLATURE FOR THE FPS

EXAMPLE: PQ48B2 Q D N



FPS is denoted by a 3-letter suffix.

OUTPUT

- Q=** Open Collector – The signal is derived from the collector of the output transistor. The output is high on pass, low on fail, and is set to trip at a certain RPM level. Downstream electronics can be tied between the supply voltage (Vcc) and output only.
- N=** Inverted Open Collector – The signal is derived from the collector of the output transistor. The output is low on pass, high on fail, and is set to trip at a certain RPM level. Down-stream electronics can be tied between the supply voltage (Vcc) and output only.
- T=** TTL Compatible – This is the same as an open collector output, but has an internal pull-up resistor tied between the supply voltage (Vcc) and the collector of the output transistor. The output signal is high on pass (logical 1) and low on failure (logical 0), and is set to trip at a certain RPM level. Downstream electronics can be tied between the supply voltage (Vcc) and/or output and ground.
- R=** Inverted TTL Compatible – This is the same as an open collector output, but has an internal pull-up resistor tied between the supply voltage (Vcc) and the collector of the output transistor. The output signal is low on pass (logical 0) and high on failure (logical 1) and is set to trip at a certain RPM level. Downstream electronics can be tied between the supply voltage (Vcc) and/or output and ground.

DELAY FEATURES

- D=** 10±4 second delay – The failure signal is delayed approximately 10 seconds, thereby eliminating temporary or nuisance failure indication such as at fan start up.
- N=** < 1 second delay

LATCH FEATURES

- L=** Latched – Once the sensor outputs a failure signal, that signal is latched on even if the fan goes back into a pass condition. The latch is reset by interrupting the power to the FPS and the output load.
- N=** No Latch.

CIRCUIT OPERATION

The circuit (previous page) utilizes the bipolar signal output option with delay feature (10+-4 seconds) and latch feature. The output signal is used to power two LEDs: one labelled to indicate proper operation of the cooling fan and one labelled to indicate failure. Failure indication is determined as the fan rotational speed falls below the nominal 1900 RPM for less than 10 seconds. Rotational speed less than nominal value may be caused by a reduced applied voltage to the fan, a physical obstruction impeding fan rotation, or failure of the motor or bearing.

Should the fan then speed up above minimum speed, the failure indicator would remain on. The latch feature maintains the failure indication until a system operator resets the FPS. The FPS is reset by interrupting the FPS supply voltage and output load for more than 40 milliseconds.

An advantage of this FPS design is the continual fan status indication. Because of the latch feature chosen in this example, the user need not constantly monitor the pass/fail LED indicators in order to determine if a failure has occurred.

The delay feature specified in this example will not allow a failure indication on start-up unless the fan fails to reach the specified minimum nominal rotational speed (1900RPM) within ten seconds. If the delay option had not been specified, the failure indicator would have been lit until the fan reached minimum speed. The pass indicator will be lit during normal operation.

AC Fan Performance Sensor (FPS)

For Major and Patriot AC Fans

Thermal management of electronic packages is increasingly challenging as package sizes decrease and circuit complexities increase. In order to avoid critical internal temperature increases within the electronic system, it is necessary to make provisions for a continuous supply of cooling airflow by monitoring and remote warning of potential airflow interruption.

Comair Rotron supplies a variety of Fan Performance Sensor-equipped Major & Patriot AC fans which provide both monitoring and remote warning capabilities. Should cooling airflow be reduced or interrupted due to a drop in RPM, these FPS systems can trigger back-up cooling devices to go on line, or for less critical equipment, for system shutdown in order to avoid excessive internal temperature rise.

Two different types of Fan Performance Sensors are currently available for the Major & Patriot AC product line. All are designed around an electrically isolated pick-up coil (flux pick-up) which generates an AC signal with an amplitude proportional to the speed of the fan and the voltage applied to the fan. This output signal is then conditioned by additional electronic circuitry to yield a discrete pass or fail signal.

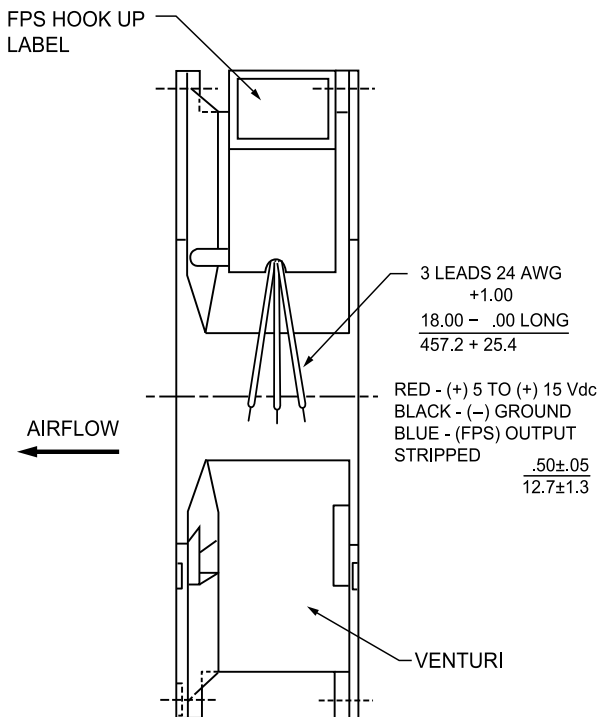

NOMENCLATURE FOR THE FPS

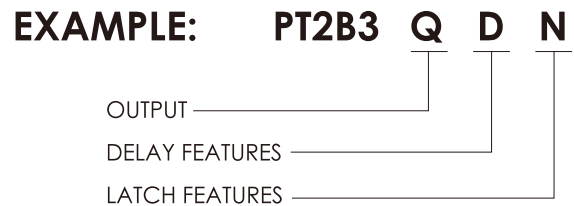

OUTPUT

- Q=** Open Collector – The signal is derived from the collector of the output transistor. The output is high on pass, low on fail. Downstream electronics can be tied between the supply voltage (Vcc) and output only.
- T=** TTL Compatible – This is the same as an open collector output, but has an internal pull-up resistor tied between the supply voltage (Vcc) and the collector of the output transistor. The output signal is high on pass (logical 1) and low on failure (logical 0). Downstream electronics can be tied between the supply voltage (Vcc) and/or output and ground.

DELAY FEATURES

- D=** 10±4 second delay -- The failure signal, that signal is delayed approximately 10 seconds, thereby eliminating temporary or nuisance failure indication such as at fan start-up.
- N=** < 1 second delay

LATCH FEATURES

- L=** Latched – Once the sensor outputs a failure signal, that signal is latched on even if the fan goes back into a pass condition. The latch is reset by interrupting the power to the FPS and the output load.
- N=** No Latch.

TYPICAL FPS APPLICATION EXAMPLE

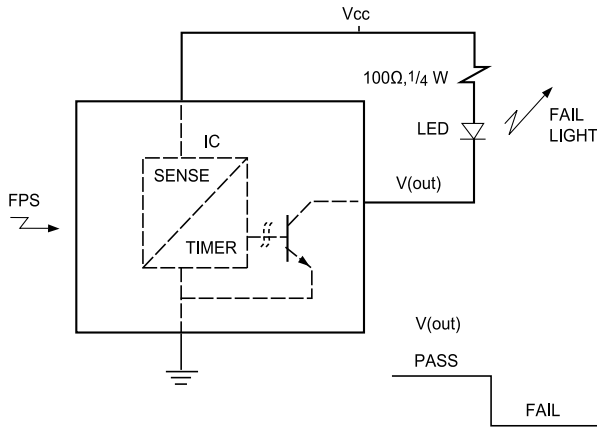

CIRCUIT DESIGN

This circuit (above) utilizes the open collector output option with delay feature (10±4 seconds) and latch feature. The output signal is used to power one LED labelled to indicate failure. Failure indication is determined as a fan sees the equivalent of 80 VAC, 60 Hz. Rotational speed less than this nominal value may be caused by a reduced applied voltage to the fan, a physical obstruction impeding fan rotation or failure of the motor or bearing.

CIRCUIT OPERATION

The red FPS lead is applied to the FPS power source (+5 to +15 Vdc), the black FPS lead to ground, and the blue output lead as shown in the above schematic. Power is applied to the fan, which will start and reach full rotational speed (3350 RPM) in five to ten seconds. The delay feature specified in this example will not allow a failure indication on start-up unless the fan fails to reach the specified minimum operating point (80 VAC, 60 Hz.) within ten seconds. If the delay option had not been specified, the failure indicator would have been lit until the fan reached minimum operating level.

Should a failure occur or fan rotational speed drop below the minimum for more than ten seconds, the failure indicator would be illuminated. Should the fan then speed up above the minimum level the failure indicator would remain on. The latch feature maintains the failure indication until a system operator resets the FPS. The FPS is reset by interrupting the FPS supply voltage and output load for more than 40 milliseconds. An advantage of this FPS design is the continual fan status indication. Because of the latch feature chosen in this example, the user need not constantly monitor the pass/fail LED indicators in order to determine if a failure has occurred.

SPECIFICATIONS

PARAMETER	CONDITIONS	Open Collector (Output)	TTL (Output)
Input Voltage Requirements		5-15V _{dc}	
Supply Current (Quiescent)	V _{cc} =5V _{dc}	15 mA MAX	
	V _{cc} =15V _{dc}	30 mA MAX	
Inrush Current	V _{cc} =5V _{dc}	50 mA MAX	
Temperature	Non-Operating (Storage)	-28°C TO +70°C	
	Operating	0°C TO +60°C	
Alarm Signal	No Delay	<1 SEC	
	Delay	10 ± 4 SEC	
Alarm Set Point	115 V, 60Hz	80 ± 10 VAC	
	115 V, 50Hz	70 ± 15 VAC	
	230 V, 60Hz	165 ± 10 VAC	
	230 V, 50Hz	155 ± 15 VAC	
V _c Collector-Emitter	MAX	28 V _{dc}	
I _c Continuous Collector Current	MAX	100 mA	
V _{ce} (SAT) Collector Emitter SAT. Voltage	I _c =10mA I _c =100mA	100 mV(TYP) 200 mV(TYP)	
Pull-Up Resistance V _{cc} To Collector			1K Ω

NOTES:

- Specifications presently cover FPS used on 115V or 230V full speed (2 pole) design only. For information on half speed (4 pole) design, contact factory.
- Sample discussed above mentions voltages that only pertain to 115V models.

CR4028

40×28mm



MECHANICAL DRAWING

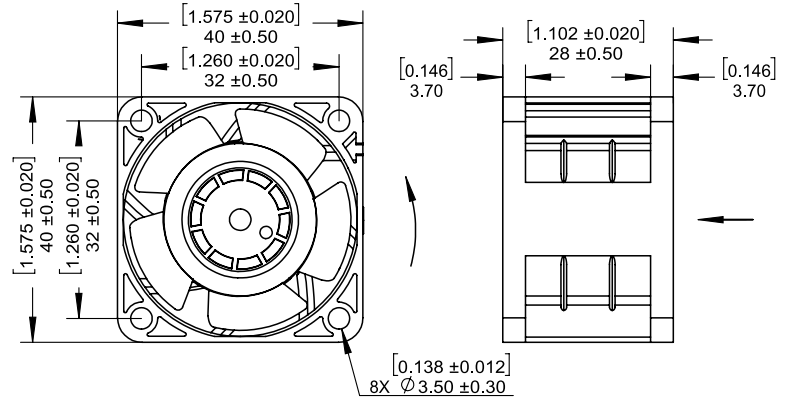
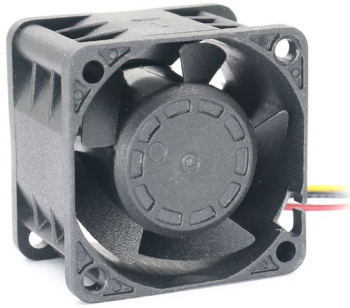

STANDARD FEATURES

- Size: 40.00 × 28.00 mm deep (1.57" × 1.10")
- Operating Temperature: -10 C to +70 C
- Storage Temperature: -40 C to +85 C
- Weight: 50 g (1.76 oz)
- Dual Ball Bearings
- Propeller: Polybutylene terephthalate
- Venturi: Polybutylene terephthalate
- 12" Lead Wires

BENEFITS

- Outstanding CFM Performance in High Pressure Systems
- Dependability with an 12 Month Warranty
- Extend Bearing Life
- Designed with optional feature Tach, PWM
- This fan is designed for continuous duty life of 45,000 Hours at 70 C (L10)

STANDARD FEATURES

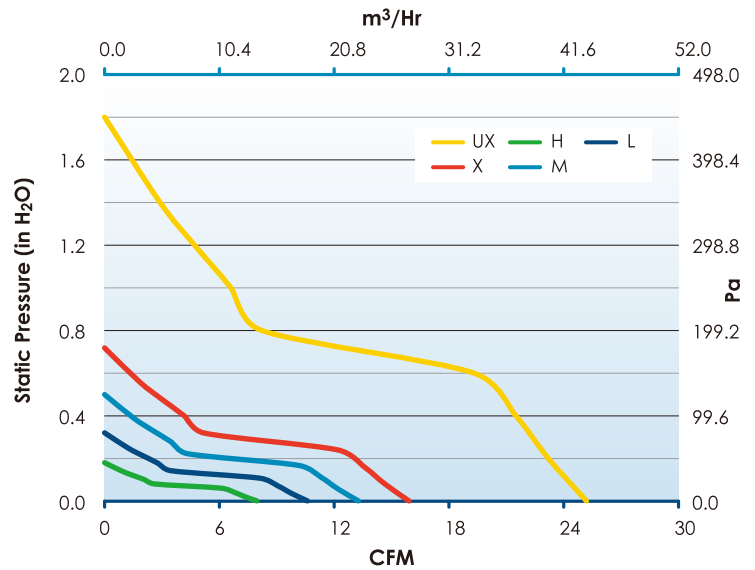

PARAMETER TABLE

Model Number	Part Number	Termination	Rated Voltage	Operating Voltage	Rated Current	Rated Input Power	Speed	Rated Air Flow		Rated Air Pressure		Noise
			VDC	VDC	Amps	Watts		RPM	CFM	m ³ /Hr	inch-H ₂ O	
CR4028-LD12BPL	17002000A	Leadwires	12	10.8~13.2	0.06	0.72	6000	8.0	13.8	0.18	45	40
CR4028-MD12BPL	17002001A	Leadwires	12	10.8~13.2	0.10	1.20	8000	10.6	18.4	0.32	79	45
CR4028-HD12BPL	17002002A	Leadwires	12	10.8~13.2	0.15	1.80	10000	13.3	23.0	0.50	125	50
CR4028-XD12BPL	17002003A	Leadwires	12	10.8~13.2	0.23	2.76	12000	15.9	27.5	0.72	179	56
CR4028-LD24BPL	17002004A	Leadwires	24	21.6~26.4	0.06	1.44	6000	8.0	13.8	0.18	45	40
CR4028-MD24BPL	17002005A	Leadwires	24	21.6~26.4	0.08	1.92	8000	10.6	18.4	0.32	79	45
CR4028-HD24BPL	17002006A	Leadwires	24	21.6~26.4	0.11	2.64	10000	13.3	23.0	0.50	125	50
CR4028-UXD24BPL	17002007A	Leadwires	24	21.6~26.4	0.45	10.80	19000	25.2	42.8	1.80	448	66

CR6025

60×25mm



MECHANICAL DRAWING

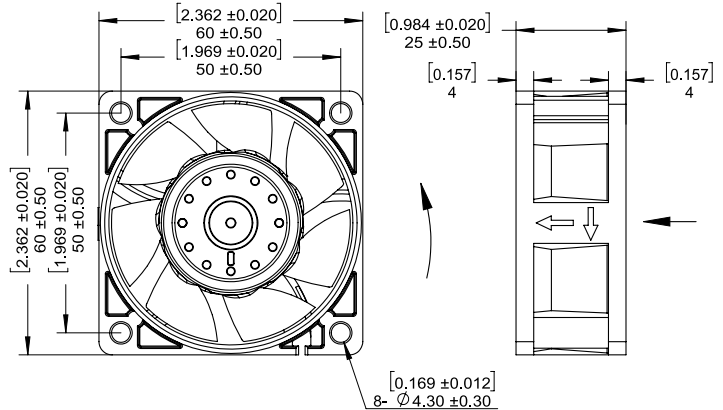

STANDARD FEATURES

- Size: 60.00 × 25.00 mm deep (2.36" × 0.98")
- Operating Temperature: -10°C to +70°C
- Storage Temperature: -40°C to +85°C
- Weight: 70 g (2.47 oz)
- Dual Ball Bearings
- Propeller: Polybutylene terephthalate
- Venturi: Polybutylene terephthalate
- 12" Lead Wires

STANDARD FEATURES

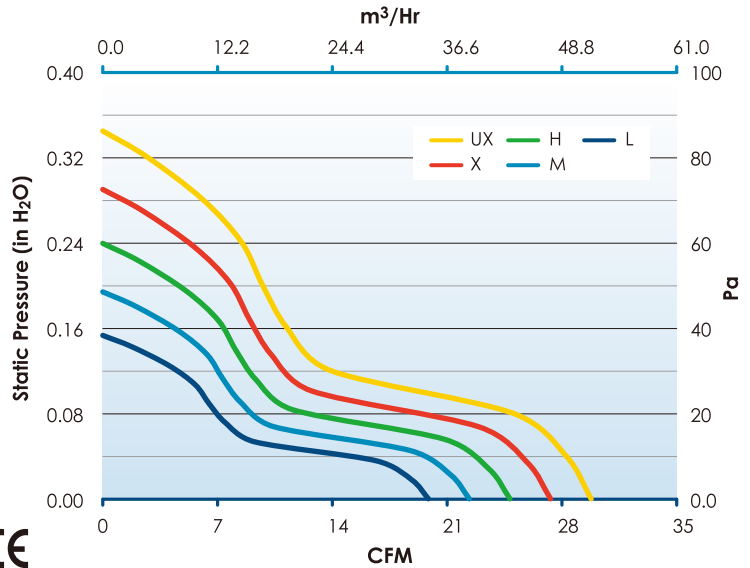

BENEFITS

- Outstanding CFM Performance in High Pressure Systems
- Dependability with an 12 Month Warranty
- Extend Bearing Life
- Designed with optional feature Tach, PWM
- This fan is designed for continuous duty life of 45,000 Hours at 70°C (L10)

PARAMETER TABLE



Model Number	Part Number	Termination	Rated Voltage	Operating Voltage	Rated Current	Rated Input Power	Speed	Rated Air Flow		Rated Air Pressure		Noise
			VDC	VDC	Amps	Watts		CFM	m³/Hr	inch-H ₂ O	Pascal	
CR6025-LD12BPL	17002008A	Leadwires	12	10.8~13.2	0.08	0.96	4000	19.9	34.4	0.15	38	46
CR6025-MD12BPL	17002009A	Leadwires	12	10.8~13.2	0.10	1.20	4500	22.4	38.7	0.19	48	48
CR6025-HD12BPL	17002010A	Leadwires	12	10.8~13.2	0.12	1.44	5000	24.8	43.0	0.24	60	50
CR6025-XD12BPL	17002011A	Leadwires	12	10.8~13.2	0.16	1.92	5500	27.3	47.3	0.29	72	52
CR6025-UXD12BPL	17002012A	Leadwires	12	10.8~13.2	0.22	2.64	6000	29.8	50.6	0.35	86	54
CR6025-LD24BPL	17002013A	Leadwires	24	21.6~26.4	0.07	1.68	4000	19.9	34.4	0.15	38	46
CR6025-MD24BPL	17002014A	Leadwires	24	21.6~26.4	0.09	2.16	4500	22.4	38.7	0.19	48	48
CR6025-HD24BPL	17002015A	Leadwires	24	21.6~26.4	0.12	2.88	5000	24.8	43.0	0.24	60	50
CR6025-XD24BPL	17002016A	Leadwires	24	21.6~26.4	0.18	4.32	5500	27.3	47.3	0.29	72	52
CR6025-UXD24BPL	17002017A	Leadwires	24	21.6~26.4	0.21	5.04	6000	29.8	50.6	0.35	86	54
CR6025-LD48BPL	17002018A	Leadwires	48	43.2~52.8	0.040	1.92	4000	19.9	34.4	0.15	38	46
CR6025-MD48BPL	17002019A	Leadwires	48	43.2~52.8	0.045	2.16	4500	22.4	38.7	0.19	48	48
CR6025-HD48BPL	17002020A	Leadwires	48	43.2~52.8	0.060	2.88	5000	24.8	43.0	0.24	60	50
CR6025-XD48BPL	17002021A	Leadwires	48	43.2~52.8	0.070	3.36	5500	27.3	47.3	0.29	72	52
CR6025-UXD48BPL	17002022A	Leadwires	48	43.2~52.8	0.080	3.84	6000	29.8	50.6	0.35	86	54

CR8025

80×25mm



MECHANICAL DRAWING

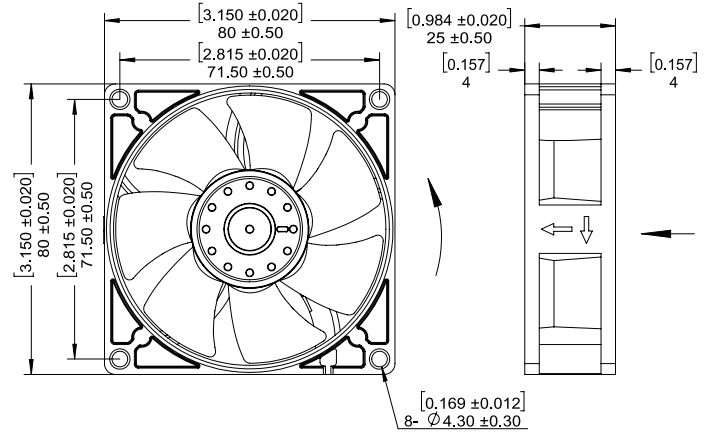

STANDARD FEATURES

- Size: 80.00 × 25.00 mm deep (3.15" × 0.98")
- Operating Temperature: -10°C to +70°C
- Storage Temperature: -40°C to +85°C
- Weight: 80 g (2.82 oz)
- Dual Ball Bearings
- Propeller: Polybutylene terephthalate
- Venturi: Polybutylene terephthalate
- 12" Lead Wires

BENEFITS

- Outstanding CFM Performance in High Pressure Systems
- Dependability with an 12 Month Warranty
- Extend Bearing Life
- Designed with optional feature Tach, PWM
- This fan is designed for continuous duty life of 45,000 Hours at 70°C (L10)

STANDARD FEATURES

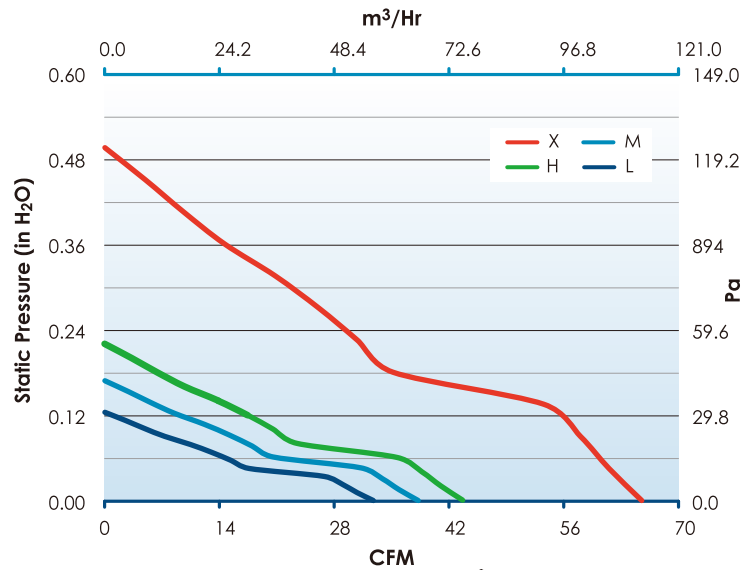

PARAMETER TABLE

Model Number	Part Number	Termination	Rated Voltage	Operating Voltage	Rated Current	Rated Input Power	Speed	Rated Air Flow		Rated Air Pressure		Noise
			VDC	VDC				Amps	Watts	RPM	CFM	
CR8025-LD12BPL	17002023A	Leadwires	12	10.8~13.2	0.08	0.96	3000	32.8	56.8	0.12	31	44
CR8025-MD12BPL	17002024A	Leadwires	12	10.8~13.2	0.11	1.32	3500	38.3	66.2	0.17	42	46
CR8025-HD12BPL	17002025A	Leadwires	12	10.8~13.2	0.16	1.92	4000	43.7	74.3	0.22	55	48
CR8025-XD12BPL	17002026A	Leadwires	12	10.8~13.2	0.50	6.00	6000	65.6	113.5	0.50	124	56
CR8025-LD24BPL	17002027A	Leadwires	24	21.6~26.4	0.08	1.92	3000	32.8	56.8	0.12	31	44
CR8025-MD24BPL	17002028A	Leadwires	24	21.6~26.4	0.11	2.64	3500	38.3	66.2	0.17	42	46
CR8025-HD24BPL	17002029A	Leadwires	24	21.6~26.4	0.16	3.84	4000	43.7	74.3	0.22	55	48
CR8025-XD24BPL	17002030A	Leadwires	24	21.6~26.4	0.28	6.72	6000	65.6	113.5	0.50	124	56
CR8025-LD48BPL	17002031A	Leadwires	48	43.2~52.8	0.03	1.44	3000	32.8	56.8	0.12	31	44
CR8025-MD48BPL	17002032A	Leadwires	48	43.2~52.8	0.05	2.40	3500	38.3	66.2	0.17	42	46
CR8025-HD48BPL	17002033A	Leadwires	48	43.2~52.8	0.07	3.36	4000	43.7	74.3	0.22	55	48
CR8025-XD48BPL	17002034A	Leadwires	48	43.2~52.8	0.14	6.72	6000	65.6	113.5	0.50	124	56



Sprint DC

80×32mm



MECHANICAL DRAWING

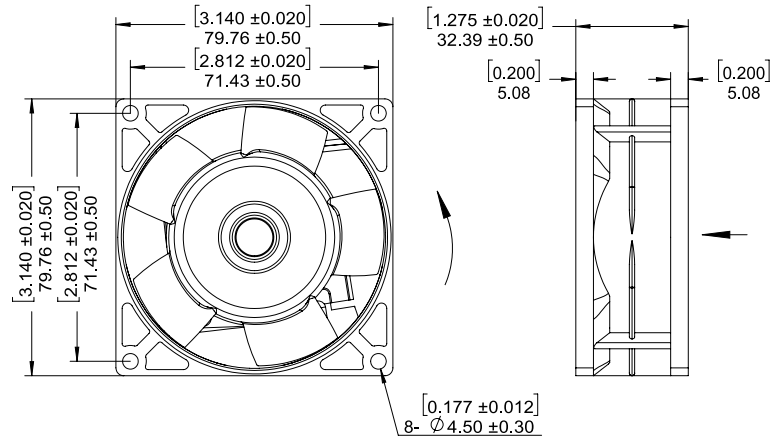

STANDARD FEATURES

- Size: 79.76 × 32.39 mm deep (3.14" × 1.28")
- Operating Temperature: -10°C to +70°C
- Storage Temperature: -40°C to +85°C
- Weight: 180 g (6.3 oz)
- Dual Ball Bearings
- Propeller: Polypropylene
- Venturi: Glass Filled Nylon
- 12" Lead Wires

BENEFITS

- Outstanding CFM Performance in High Pressure Systems
- Dependability with an 12 Month Warranty
- Extend Bearing Life
- Designed with optional feature
 Speed control: Linear voltage, PWM, Thermal sensor
 Feedback: Tach , FPS
- This fan is designed for continuous duty life of 45,000 Hours at 70°C (L10)

STANDARD FEATURES

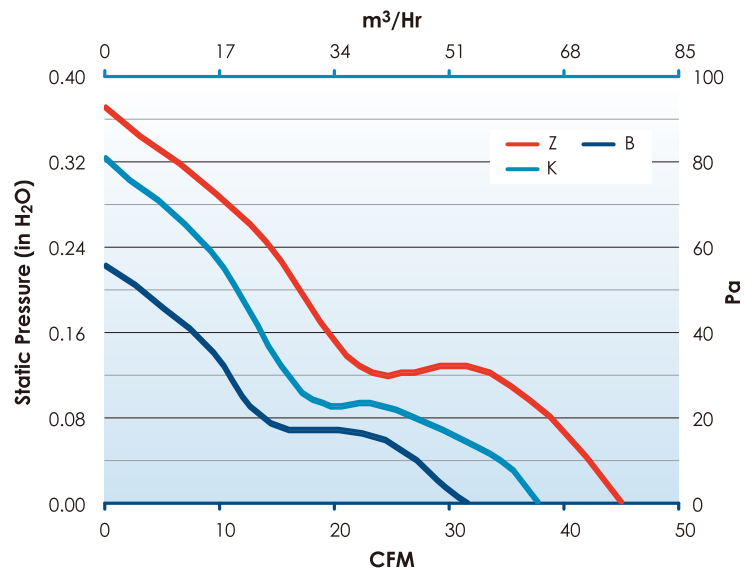

PARAMETER TABLE

Model Number	Part Number	Termination	Rated Voltage	Operating Voltage	Rated Current	Rated Input Power	Speed	Rated Air Flow		Rated Air Pressure		Noise
			VDC	VDC	Amps	Watts		CFM	m³/Hr	inch-H ₂ O	Pascal	
ST05B3	19030829A	Leadwires	5	4~6	0.46	2.3	3400	32	54.4	0.23	57	40.9
ST12B3	19030615A	Leadwires	12	6~14	0.28	3.4	3400	32	54.4	0.23	57	40.9
ST24B3	19030616A	Leadwires	24	12~28	0.14	3.3	3400	32	54.4	0.23	57	40.9
ST48B3	19032871A	Leadwires	48	24~56	0.07	3.6	3400	32	54.4	0.23	57	40.9
ST12K3	19030613A	Leadwires	12	6~14	0.38	4.4	4200	38	64.6	0.33	81	44.2
ST24K3	19030614A	Leadwires	24	12~28	0.19	4.5	4200	38	64.6	0.33	81	44.2
ST48K3	19039286A	Leadwires	48	24~56	0.11	5.3	4200	38	64.6	0.33	81	44.2
ST12Z3	19039067A	Leadwires	12	6~14	0.52	6.2	4700	45	76.5	0.37	92	51.5
ST24Z3	19032556A	Leadwires	24	12~28	0.25	6.0	4700	45	76.5	0.37	92	51.5
ST48Z3	17000002A	Leadwires	48	24~56	0.12	5.8	4700	45	76.5	0.37	92	51.5

Sprite DC

80×42mm



MECHANICAL DRAWING

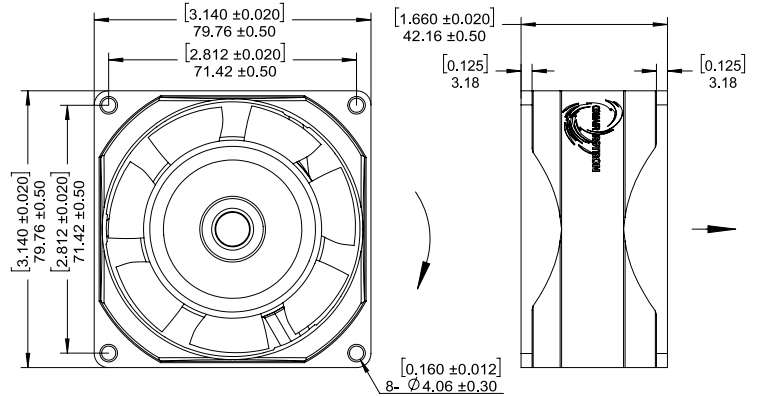

STANDARD FEATURES

- Size: 79.76 × 42.16 mm deep (3.14" × 1.66")
- Operating Temperature: -10°C to +70°C
- Storage Temperature: -40°C to +85°C
- Weight: 340 g (12.0 oz)
- Dual Ball Bearings
- Propeller: Polypropylene
- Venturi: Metal Alloy
- 12" Lead Wires

BENEFITS

- Outstanding CFM Performance in High Pressure Systems
- Dependability with an 12 Month Warranty
- Extend Bearing Life
- Designed with optional feature
Speed control: Linear voltage, PWM, Thermal sensor
Feedback: Tach , FPS
- This fan is designed for continuous duty life of 52,000 Hours at 70°C (L10)

STANDARD FEATURES

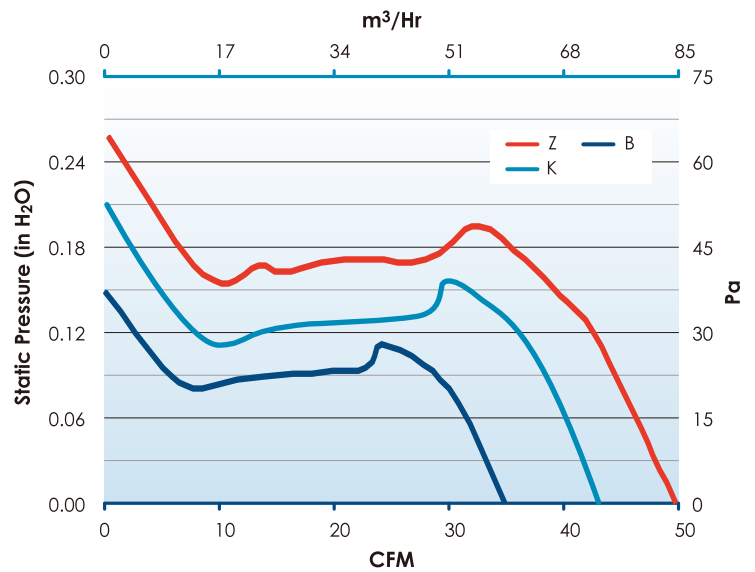

PARAMETER TABLE

Model Number	Part Number	Termination	Rated Voltage	Operating Voltage	Rated Current	Rated Input Power	Speed	Rated Air Flow		Rated Air Pressure		Noise
			VDC	VDC				Amps	Watts	RPM	CFM	
SD12B1	19028933A	Leadwires	12	6~14	0.25	3.0	3500	35	59.5	0.15	37	47.6
SD24B1	19028934A	Leadwires	24	12~28	0.13	3.0	3500	35	59.5	0.15	37	47.6
SD48B1	19028935A	Leadwires	48	24~56	0.06	3.0	3500	35	59.5	0.15	37	47.6
SD12K1	17000003A	Leadwires	12	6~14	0.43	5.2	4200	43	72.9	0.21	53	52.1
SD24K1	17000004A	Leadwires	24	12~28	0.22	5.2	4200	43	72.9	0.21	53	52.1
SD48K1	17000005A	Leadwires	48	24~56	0.11	5.2	4200	43	72.9	0.21	53	52.1
SD12Z1	17000263A	Leadwires	12	6~14	0.68	8.1	4900	50	85.0	0.26	64	55.4
SD24Z1	17000264A	Leadwires	24	12~28	0.32	7.7	4900	50	85.0	0.26	64	55.4
SD48Z1	17000265A	Leadwires	48	24~56	0.16	7.5	4900	50	85.0	0.26	64	55.4

Muffin DC

120×32mm



MECHANICAL DRAWING

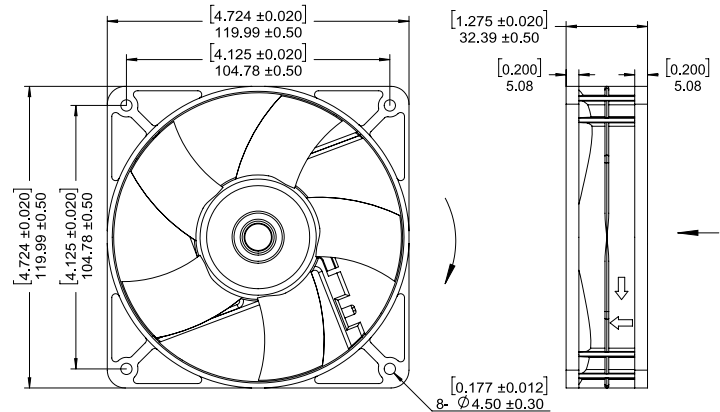

STANDARD FEATURES

- Size: 119.99 × 32.39 mm deep (4.72" × 1.28")
- Operating Temperature: -10°C to +70°C
- Storage Temperature: -40°C to +85°C
- Weight: 240 g (8.5 oz)
- Dual Ball Bearings
- Propeller: Polypropylene
- Venturi: Polycarbonate 30% GR
- 12" Lead Wires

BENEFITS

- Outstanding CFM Performance in High Pressure Systems
- Dependability with an 12 Month Warranty
- Extend Bearing Life
- Designed with optional feature
 Speed control: Linear voltage, PWM, Thermal sensor
 Feedback: Tach , FPS
- This fan is designed for continuous duty life of 45,000 Hours at 70°C (L10)

STANDARD FEATURES

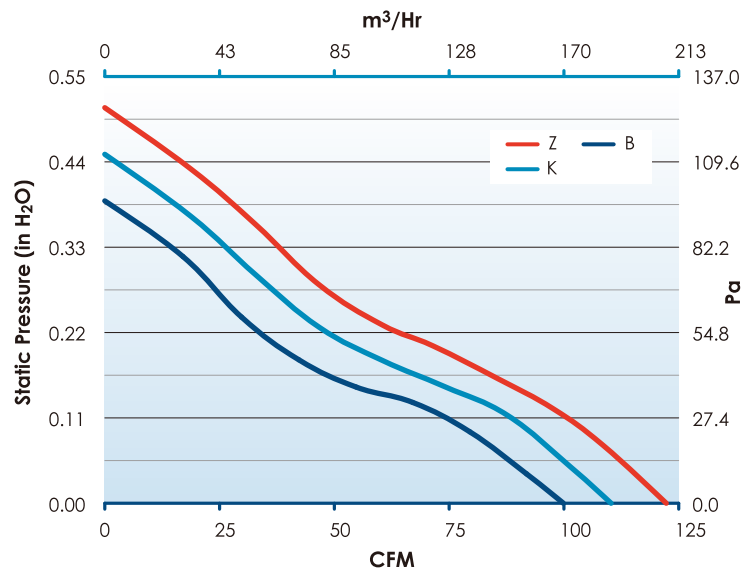

PARAMETER TABLE

Model Number	Part Number	Termination	Rated Voltage	Operating Voltage	Rated Current	Rated Input Power	Speed	Rated Air Flow		Rated Air Pressure		Noise
			VDC	VDC	Amps	Watts		CFM	m ³ /Hr	inch-H ₂ O	Pascal	
MC12B3	19032489A	Leadwires	12	6~14	0.66	7.9	3700	100	170	0.39	98	47.8
MC24B3	19030572A	Leadwires	24	12~28	0.23	5.5	3700	100	170	0.39	98	47.8
MC48B3	19030573A	Leadwires	48	24~56	0.18	8.4	3700	100	170	0.39	98	47.8
MC12K3	19039388A	Leadwires	12	6~14	0.90	10.8	4100	110	187	0.45	112	50.0
MC24K3	19031618A	Leadwires	24	12~28	0.45	10.7	4100	110	187	0.45	112	50.0
MC48K3	19031792A	Leadwires	48	24~56	0.22	10.6	4100	110	187	0.45	112	50.0
MC12Z3	17000272A	Leadwires	12	6~14	1.00	12.0	4500	122	207.3	0.51	126	52.0
MC24Z3	17000273A	Leadwires	24	12~28	0.51	12.0	4500	122	207.3	0.51	126	52.0
MC48Z3	17000274A	Leadwires	48	24~56	0.25	11.9	4500	122	207.3	0.51	126	52.0

Muffin XP DC

120×38mm



MECHANICAL DRAWING

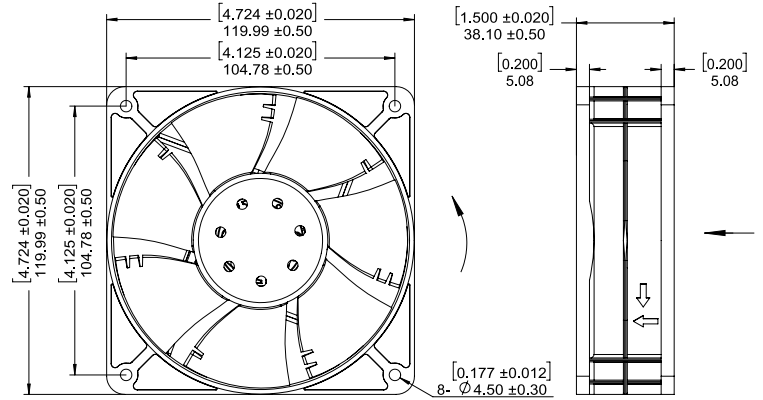

STANDARD FEATURES

- Size: 119.99 × 38.10 mm deep (4.72" × 1.50")
- Operating Temperature: -10°C to +70°C
- Storage Temperature: -40°C to +85°C
- Weight: 250 g (8.8 oz)
- Dual Ball Bearings
- Propeller: Polypropylene
- Venturi: Polycarbonate 30% GR
- 12" Lead Wires

BENEFITS

- Outstanding CFM Performance in High Pressure Systems
- Dependability with an 12 Month Warranty
- Extend Bearing Life
- Designed with optional feature
Speed control: Linear voltage, PWM, Thermal sensor
Feedback: Tach , FPS
- This fan is designed for continuous duty life of 45,000 Hours at 70°C (L10)

STANDARD FEATURES

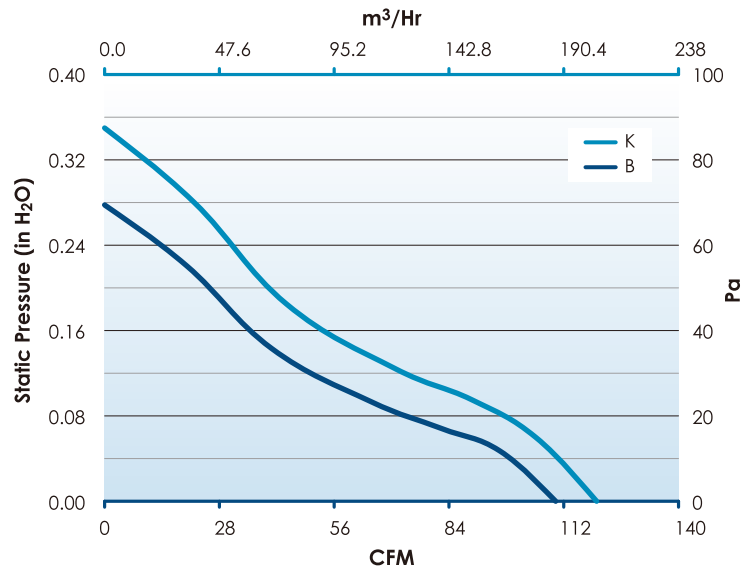

PARAMETER TABLE

Model Number	Part Number	Termination	Rated Voltage	Operating Voltage	Rated Current	Rated Input Power	Speed	Rated Air Flow		Rated Air Pressure		Noise
			VDC	VDC	Amps	Watts		CFM	m³/Hr	inch-H ₂ O	Pascal	
MS12B3	19032525A	Leadwires	12	6~14	0.58	7.0	3000	110	187	0.28	70	49.1
MS24B3	19032526A	Leadwires	24	12~28	0.29	7.0	3000	110	187	0.28	70	49.1
MS48B3	19032527A	Leadwires	48	24~56	0.15	7.2	3000	110	187	0.28	70	49.1
MS12K3	19039164A	Leadwires	12	6~14	0.92	11.0	3400	120	204	0.35	87	51.8
MS24K3	17000006A	Leadwires	24	12~28	0.45	10.8	3400	120	204	0.35	87	51.8
MS48K3	17000007A	Leadwires	48	24~56	0.22	10.6	3400	120	204	0.35	87	51.8

Whisper XL DC

120×39mm



MECHANICAL DRAWING

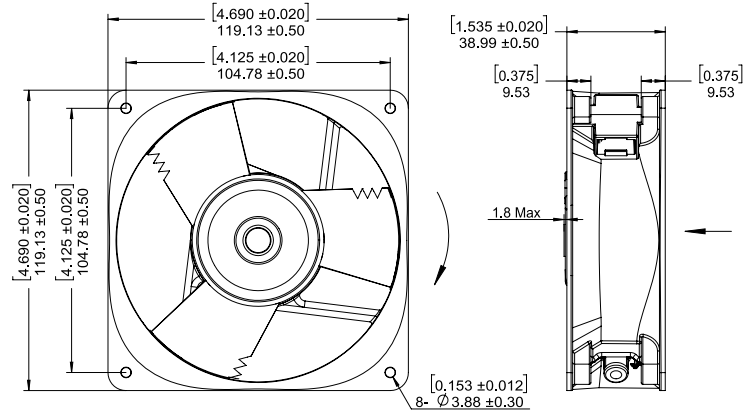

STANDARD FEATURES

- Size: 119.13 × 38.99 mm deep (4.69" × 1.54")
- Operating Temperature: -10°C to +70°C
- Storage Temperature: -40°C to +85°C
- Weight: 420 g (14.8 oz)
- Dual Ball Bearings
- Propeller: Polypropylene
- Venturi: Metal Alloy
- 12" Lead Wires

BENEFITS

- Outstanding CFM Performance in High Pressure Systems
- Dependability with an 12 Month Warranty
- Extend Bearing Life
- Designed with optional feature
 Speed control: Linear voltage, PWM, Thermal sensor
 Feedback: Tach , FPS
- This fan is designed for continuous duty life of 55,000 Hours at 70°C (L10)

STANDARD FEATURES

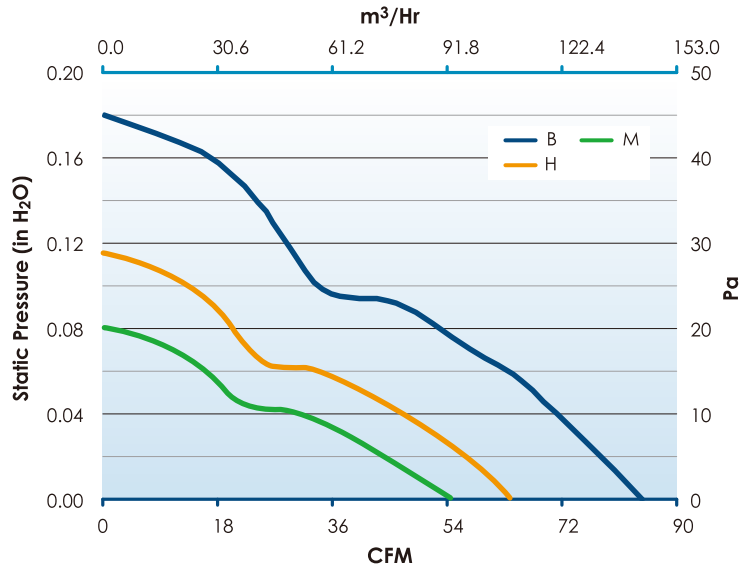

PARAMETER TABLE

Model Number	Part Number	Termination	Rated Voltage	Operating Voltage	Rated Current	Rated Input Power	Speed	Rated Air Flow		Rated Air Pressure		Noise
			VDC	VDC	Amps	Watts		RPM	CFM	m ³ /Hr	inch-H ₂ O	
WD12M3	19030723A	Leadwires	12	6~14	0.10	1.2	1650	55	93.5	0.08	20	30.3
WD24M3	19030725A	Leadwires	24	12~28	0.05	1.2	1650	55	93.5	0.08	20	30.3
WD48M3	17000270A	Leadwires	48	24~56	0.03	1.2	1650	55	93.5	0.08	20	30.3
WD12H3	19030719A	Leadwires	12	6~14	0.17	2.1	1950	65	110.5	0.115	28	34.9
WD24H3	19030721A	Leadwires	24	12~28	0.08	1.9	1950	65	110.5	0.115	28	34.9
WD48H3	17000271A	Leadwires	48	24~56	0.04	1.9	1950	65	110.5	0.115	28	34.9
WD12B3	19030709A	Leadwires	12	6~14	0.26	3.1	2450	84	142.7	0.18	45	41.4
WD24B3	19030711A	Leadwires	24	12~28	0.13	3.1	2450	84	142.7	0.18	45	41.4
WD48B3	19030713A	Leadwires	48	24~56	0.09	4.3	2450	84	142.7	0.18	45	41.4

Muffin XL DC

120×39mm



MECHANICAL DRAWING

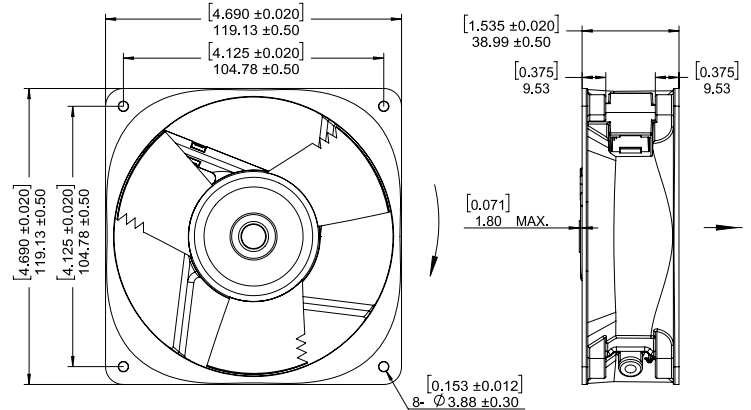

STANDARD FEATURES

- Size: 119.13 × 38.99 mm deep (4.69" × 1.54")
- Operating Temperature: -10°C to +70°C
- Storage Temperature: -40°C to +85°C
- Weight: 420 g (14.8 oz)
- U/L 507 WET
- Propeller: Polypropylene
- Venturi: Die Cast Aluminum
- 12" Lead Wires

BENEFITS

- Outstanding CFM Performance in High Pressure Systems
- Dependability with an 12 Month Warranty
- Extend Bearing Life
- Designed with optional feature
Speed control: Linear voltage, PWM, Thermal sensor
Feedback: Tach , FPS
- This fan is designed for continuous duty life of 55,000 Hours at 70°C (L10)

STANDARD FEATURES

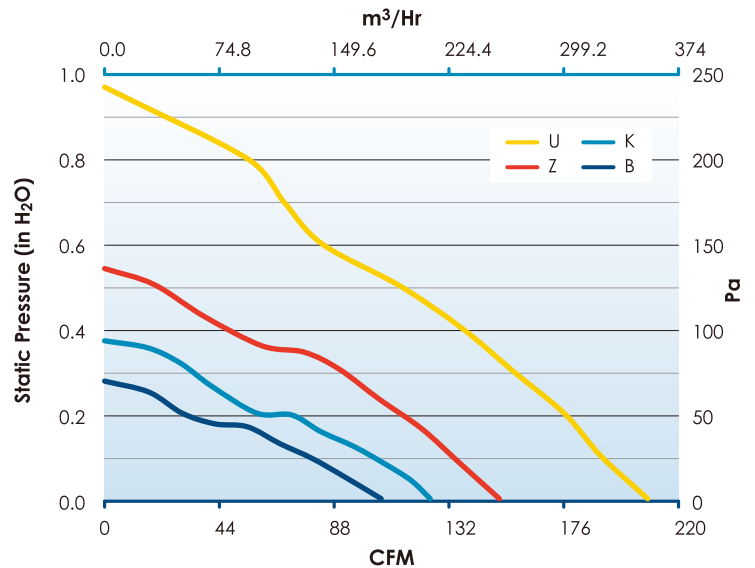

PARAMETER TABLE

Model Number	Part Number	Termination	Rated Voltage	Operating Voltage	Rated Current	Rated Input Power	Speed	Rated Air Flow		Rated Air Pressure		Noise
			VDC	VDC	Amps	Watts	RPM	CFM	m ³ /Hr	inch-H ₂ O	Pascal	
MD12B1	19028865A	Leadwires	12	6~14	0.50	6.0	3100	106	180.1	0.28	69	50.0
MD24B1	19028866A	Leadwires	24	12~28	0.25	6.0	3100	106	180.1	0.28	69	50.0
MD48B1	19028867A	Leadwires	48	24~56	0.12	5.8	3100	106	180.1	0.28	69	50.0
MD12K1	19032185A	Leadwires	12	6~14	0.72	8.6	3650	125	212.4	0.37	93	53.5
MD24K1	17000008A	Leadwires	24	12~28	0.34	8.2	3650	125	212.4	0.37	93	53.5
MD48K1	19041296A	Leadwires	48	24~56	0.16	7.7	3650	125	212.4	0.37	93	53.5
MD48Z1	19040285A	Leadwires	48	24~56	0.35	16.8	4600	150	254.9	0.54	135	58.5
MDD48U1	19040656A	Leadwires	48	24~56	0.80	38.4	6300	210	356.8	0.97	242	65.3

Galaxy DC

127×38mm



MECHANICAL DRAWING

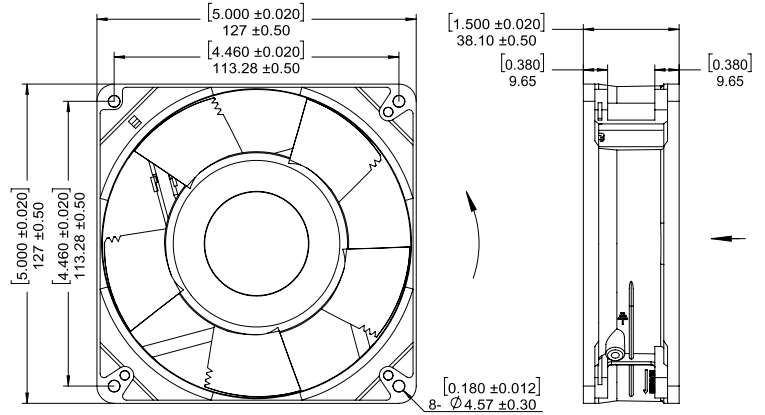

STANDARD FEATURES

- Size: 127.00 × 38.10 mm deep (5.00" × 1.50")
- Operating Temperature: -10°C to +70°C
- Storage Temperature: -40°C to +85°C
- Weight: 620 g (21.9 oz)
- U/L 507 WET
- Propeller: Polypropylene
- Venturi: Metal Alloy
- 12" Lead Wires

BENEFITS

- Outstanding CFM Performance in High Pressure Systems
- Dependability with an 12 Month Warranty
- Extend Bearing Life
- Designed with optional feature
 Speed control: Linear voltage, PWM, Thermal sensor
 Feedback: Tach , FPS
- This fan is designed for continuous duty life of 60,000 Hours at 70°C (L10)

STANDARD FEATURES

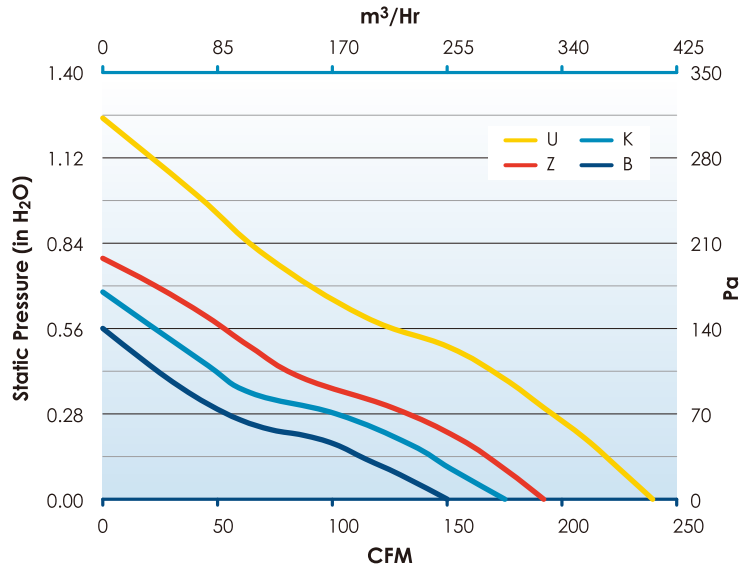

PARAMETER TABLE

Model Number	Part Number	Termination	Rated Voltage	Operating Voltage	Rated Current	Rated Input Power	Speed	Rated Air Flow		Rated Air Pressure		Noise
			VDC	VDC	Amps	Watts		CFM	m ³ /Hr	inch-H ₂ O	Pascal	
GL12B3	19031711A	Leadwires	12	6~14	1.30	15.6	3200	144	244.7	0.49	121	53.6
GL24B3	19031757A	Leadwires	24	12~28	0.63	15.1	3200	144	244.7	0.49	121	53.6
GL48B3	17000009A	Leadwires	48	24~56	0.31	14.9	3200	144	244.7	0.49	121	53.6
GL12K3	19039710A	Leadwires	12	6~14	1.99	23.9	3900	175	297.3	0.68	169	57.9
GL24K3	19039193A	Leadwires	24	12~28	0.95	22.8	3900	175	297.3	0.68	169	57.9
GL48K3	19039151A	Leadwires	48	24~56	0.47	22.6	3900	175	297.3	0.68	169	57.9
GL12Z3	19039193A	Leadwires	12	6~14	2.63	31.6	4100	192	326.2	0.79	197	59.4
GL24Z3	19039773A	Leadwires	24	12~28	1.30	31.2	4100	192	326.2	0.79	197	59.4
GL48Z3	17000010A	Leadwires	48	24~56	0.60	28.8	4100	192	326.2	0.79	197	59.4
GLD24U3E	19040725A	Leadwires	24	12~28	1.63	39.1	5200	240	407.8	1.25	311	65.0
GLD48U3D	19041165A	Leadwires	48	24~56	0.80	38.4	5200	240	407.8	1.25	311	65.0



Major DC

172×150×51mm



MECHANICAL DRAWING

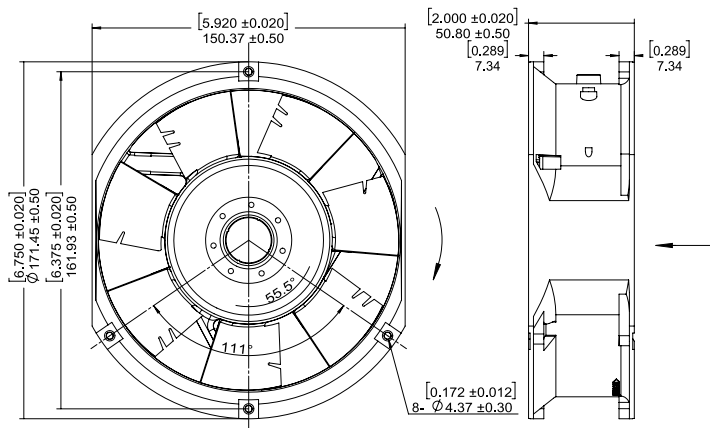

STANDARD FEATURES

- Size: 171.45 × 150.37 × 50.80 mm deep (6.75" × 5.92" × 2.00")
- Operating Temperature: -10 C to +70 C
- Storage Temperature: -40 C to +85 C
- Weight: 840 g (1.85 lbs)
- U/L 507 WET
- Propeller: Polycarbonate, UL94V-0
- Venturi: Die Cast Aluminum

BENEFITS

- Outstanding CFM Performance in High Pressure Systems
- Dependability with an 12 Month Warranty
- Extend Bearing Life
- Designed with optional feature
Speed control: Linear voltage, PWM, Thermal sensor
Feedback: Tach , FPS
- Customerized Termination
- This fan is designed for continuous duty life of 58,000 Hours at 70 C (L10)

STANDARD FEATURES

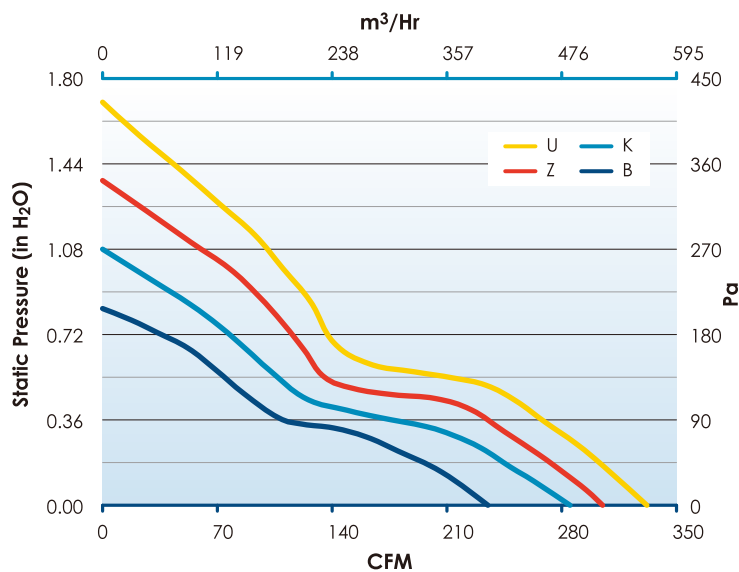

PARAMETER TABLE

Model Number	Part Number	Termination	Rated Voltage	Operating Voltage	Rated Current	Rated Input Power	Speed	Rated Air Flow		Rated Air Pressure		Noise
			VDC	VDC	Amps	Watts	RPM	CFM	m ³ /Hr	inch-H ₂ O	Pascal	
JQ12B4	19031089A	Leadwires	12	6~14	2.26	27.1	3400	235	399.3	0.83	207	54.3
JQ24B4	19031090A	Leadwires	24	12~28	1.00	24.0	3400	235	399.3	0.83	207	54.3
JQ48B4	19031091A	Leadwires	48	24~56	0.46	22.1	3400	235	399.3	0.83	207	54.3
JQ24K4	17000011A	Leadwires	24	12~28	1.80	43.2	4200	285	484.2	1.17	290	58.9
JQ48K4	17000012A	Leadwires	48	24~56	0.90	43.2	4200	285	484.2	1.17	290	58.9
JQD24Z3	17000013A	Leadwires	24	16~32	1.30	31.2	4500	305	518.2	1.48	368	60.4
JQD48Z3	17000014A	Leadwires	48	28~72	0.67	32.2	4500	305	518.2	1.48	368	60.4
JQD24U3E2	19041049A	Leadwires	24	16~32	1.70	40.8	4830	332	564.1	1.70	423	64.0
JQD48U3E2	19040422A	Leadwires	48	28~72	0.85	40.8	4830	332	564.1	1.70	423	64.0



Patriot DC

172×51mm

MECHANICAL DRAWING

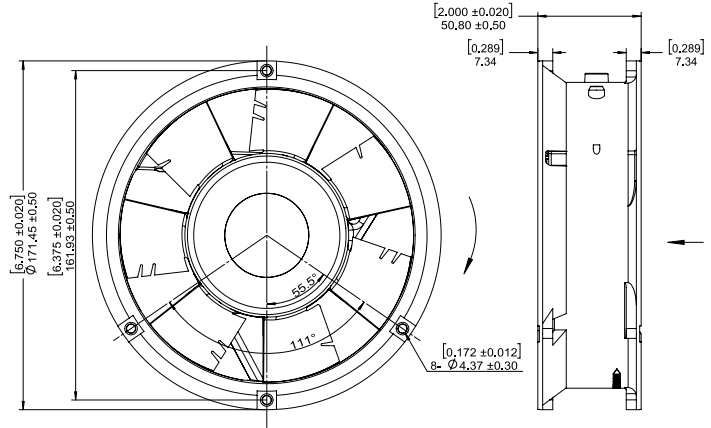

STANDARD FEATURES

- Size: 171.45 × 50.80 mm deep (6.75" × 2.00")
- Operating Temperature: -10 C to +70 C
- Storage Temperature: -40 C to +85 C
- Weight: 840 g (1.85 lbs)
- U/L 507 WET
- Propeller: Polycarbonate, UL94V-0
- Venturi: Die Cast Aluminum

BENEFITS

- Outstanding CFM Performance in High Pressure Systems
- Dependability with an 12 Month Warranty
- Extend Bearing Life
- Designed with optional feature
Speed control: Linear voltage, PWM, Thermal sensor
Feedback: Tach , FPS
- Customized Termination
- This fan is designed for continuous duty life of 58,000 Hours at 70 C (L10)

STANDARD FEATURES

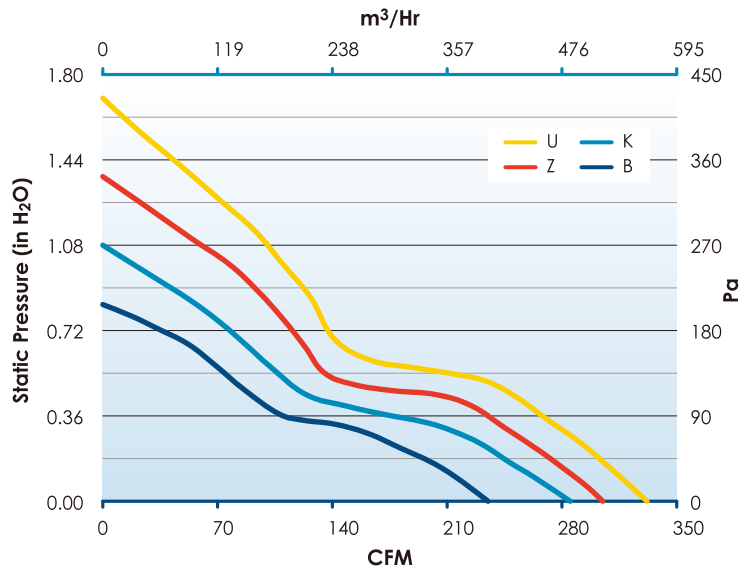

PARAMETER TABLE

Model Number	Part Number	Termination	Rated Voltage	Operating Voltage	Rated Current	Rated Input Power	Speed	Rated Air Flow		Rated Air Pressure		Noise
			VDC	VDC	Amps	Watts		CFM	m³/Hr	inch-H ₂ O	Pascal	
PQ12B4	19031083A	Leadwires	12	6~14	2.26	27.1	3400	235	399.3	0.83	207	54.3
PQ24B4	19031084A	Leadwires	24	12~28	1.00	24.0	3400	235	399.3	0.83	207	54.3
PQ48B4	19031085A	Leadwires	48	24~56	0.46	22.1	3400	235	399.3	0.83	207	54.3
PQ24K4	17000015A	Leadwires	24	12~28	1.80	43.2	4200	285	484.2	1.17	269	58.9
PQ48K4	17000016A	Leadwires	48	24~56	0.90	43.2	4200	285	484.2	1.17	269	58.9
PQD24Z3	17000017A	Leadwires	24	16~32	1.30	31.2	4500	305	518.2	1.48	341	60.4
PQD48Z3	17000018A	Leadwires	48	28~72	0.67	32.2	4500	305	518.2	1.48	341	60.4
PQD24U3E2	19040425A	Leadwires	24	16~32	1.70	40.8	4830	332	564.1	1.70	423	64.0
PQD48U3E2	19040428A	Leadwires	48	28~72	0.85	40.8	4830	332	564.1	1.70	423	64.0



Maltese DC

172×150×55mm



MECHANICAL DRAWING

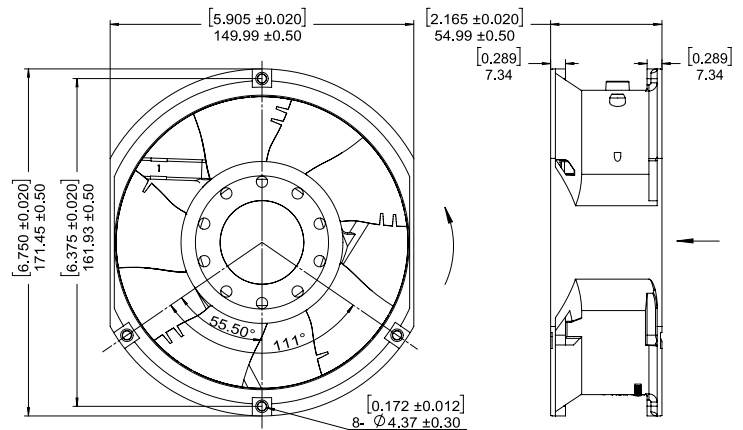

STANDARD FEATURES

- Size: 171.45 × 149.99 × 54.99 mm deep (6.75" × 5.91" × 2.17")
- Operating Temperature: -10°C to +70°C
- Storage Temperature: -40°C to +85°C
- Weight: 835 g (1.84 lbs)
- U/L 507 WET
- Dual Ball Bearings
- Propeller: Polycarbonate
- Venturi: Die Cast Aluminum
- 12" Lead Wires

BENEFITS

- Outstanding CFM Performance in High Pressure Systems
- Dependability with an 12 Month Warranty
- Extend Bearing Life
- Designed with optional feature
Speed control: Linear voltage, PWM, Thermal sensor
Feedback: Tach , FPS
- This fan is designed for continuous duty life of 52,000 Hours at 70°C (L10)

STANDARD FEATURES

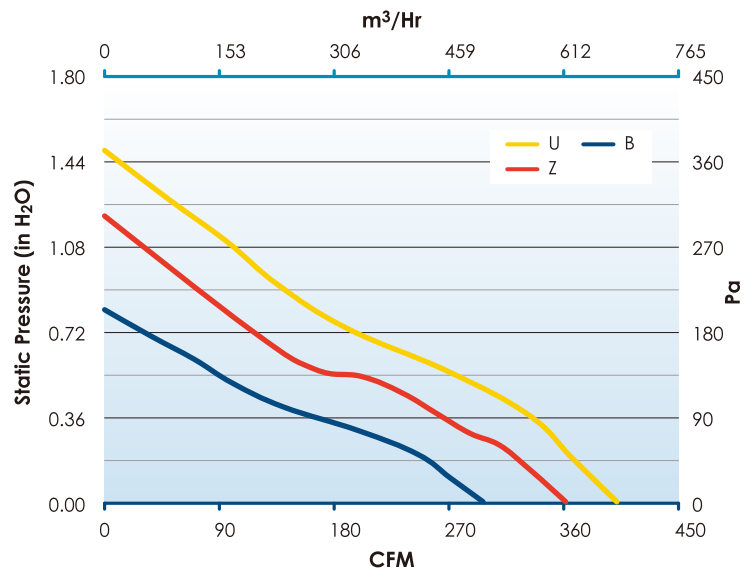

PARAMETER TABLE

Model Number	Part Number	Termination	Rated Voltage	Operating Voltage	Rated Current	Rated Input Power	Speed	Rated Air Flow		Rated Air Pressure		Noise
			VDC	VDC				Amps	Watts	RPM	CFM	
MT12B3	19031856A	Leadwires	12	6~14	3.00	36.0	3400	298	506.3	0.81	202	57.1
MT24B3	19031843A	Leadwires	24	12~28	1.70	40.8	3400	298	506.3	0.81	202	57.1
MT48B3	19031841A	Leadwires	48	24~56	0.72	34.6	3400	298	506.3	0.81	202	57.1
MTD24Z3	17000019A	Leadwires	24	12~28	2.20	52.8	4200	363	616.7	1.21	300	61.7
MTD48Z3	17000020A	Leadwires	48	24~56	1.10	52.8	4200	363	616.7	1.21	300	61.7
MTD48U3	17000022A	Leadwires	48	36~60	1.60	76.8	4650	402	695.5	1.48	368	63.9



Tarzan DC

176×107mm

MECHANICAL DRAWING

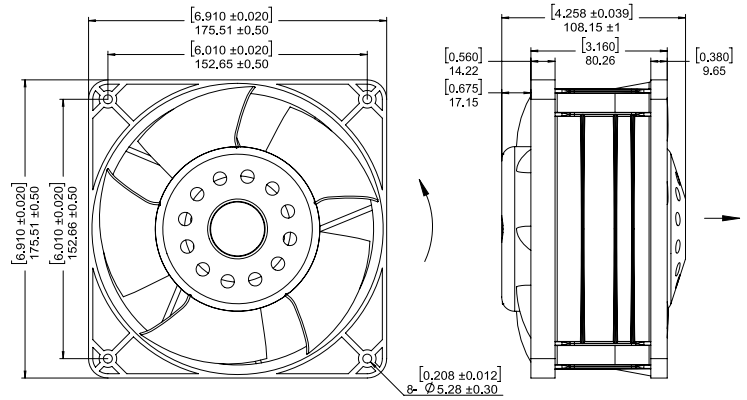

STANDARD FEATURES

- Size: 175.51 × 108.15 mm deep (6.91" × 4.26")
- Operating Temperature: -10°C to +70°C
- Storage Temperature: -40°C to +85°C
- Weight: 2.25 Kg (5.0 lbs)
- Dual Ball Bearings
- Propeller: Polycarbonate, UL94V-0
- Venturi: Plastic, UL94V-0
- 12" Lead Wires

BENEFITS

- Outstanding CFM Performance in High Pressure Systems
- Dependability with an 12 Month Warranty
- Extend Bearing Life
- Designed with optional feature
 Speed control: Linear voltage, PWM, Thermal sensor
 Feedback: Tach , FPS
- This fan is designed for continuous duty life of 42,000 Hours at 70°C (L10)

STANDARD FEATURES

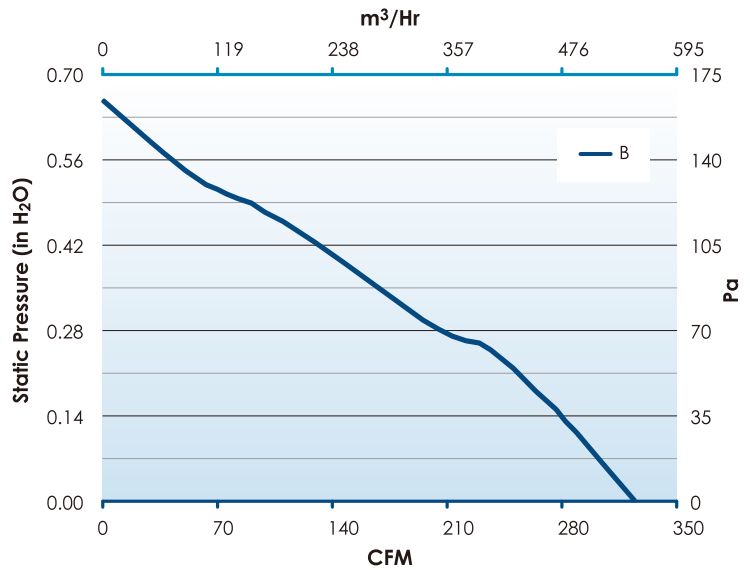

PARAMETER TABLE

Model Number	Part Number	Termination	Rated Voltage	Operating Voltage	Rated Current	Rated Input Power	Speed	Rated Air Flow		Rated Air Pressure		Noise
			VDC	VDC	Amps	Watts		RPM	CFM	m³/Hr	inch-H ₂ O	
TD12B1	19032836A	Leadwires	12	6~14	2.5	30.0	3250	325	553	0.67	167	65.2
TD24B1	19031769A	Leadwires	24	12~28	1.5	36.0	3250	325	553	0.67	167	65.2
TD48B1	19031520A	Leadwires	48	24~56	0.7	33.6	3250	325	553	0.67	167	65.2



MECHANICAL DRAWING

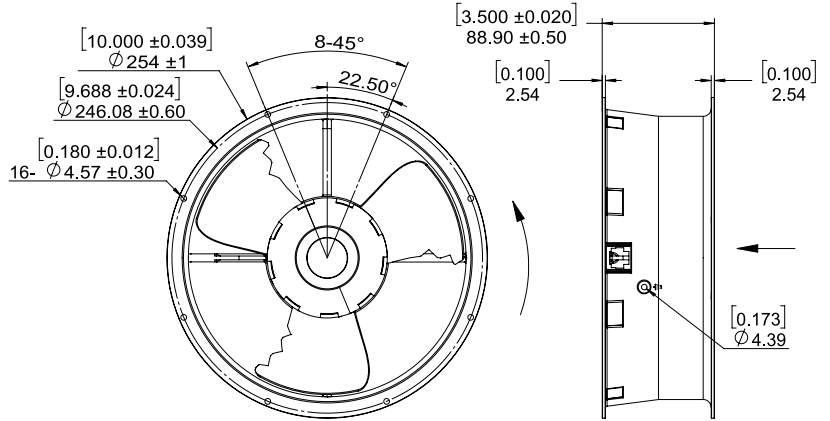

STANDARD FEATURES

- Size: 254.00 × 88.90 mm deep (10.00" × 3.50")
- Operating Temperature: -10°C to +70°C
- Storage Temperature: -40°C to +85°C
- Weight: 1.54 Kg (3.40 lbs)
- Dual Ball Bearings
- Propeller: Polycarbonate, UL94V-0
- Venturi: Die Cast Aluminum
- 12" Lead Wires

BENEFITS

- Outstanding CFM Performance in High Pressure Systems
- Dependability with an 12 Month Warranty
- Extend Bearing Life
- Designed with optional feature
Speed control: Linear voltage, PWM, Thermal sensor
Feedback: Tach , FPS
- This fan is designed for continuous duty life of 65,000 Hours at 70°C (L10)

STANDARD FEATURES

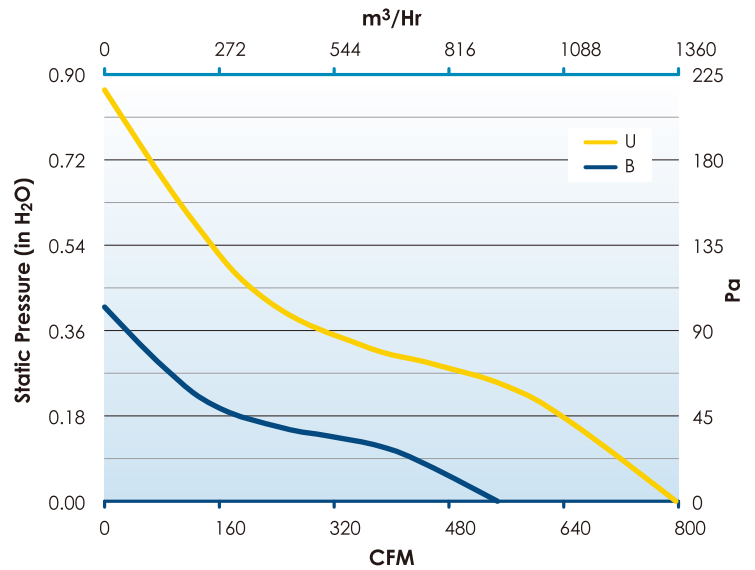

PARAMETER TABLE

Model Number	Part Number	Termination	Rated Voltage	Operating Voltage	Rated Current	Rated Input Power	Speed	Rated Air Flow		Rated Air Pressure		Noise
			VDC	VDC				Amps	Watts	RPM	CFM	
CD12B3	19032837A	Leadwires	12	6~14	2.6	31.2	1650	548	931	0.41	102	49.1
CD24B3	19031573A	Leadwires	24	12~28	1.2	28.8	1650	548	931	0.41	102	49.1
CD48B3	19031767A	Leadwires	48	24~56	0.6	28.8	1650	548	931	0.41	102	49.1
CDD12U3	17000304A	Leadwires	12	6~14	5.4	64.3	2400	797	1355	0.87	216	57.3
CDD24U3	17000305A	Leadwires	24	12~28	2.7	64.3	2400	797	1355	0.87	216	57.3
CDD48U3	17000306A	Leadwires	48	24~56	1.4	64.3	2400	797	1355	0.87	216	57.3

Mixtus 6.8 DC

172×51mm E Series

MECHANICAL DRAWING

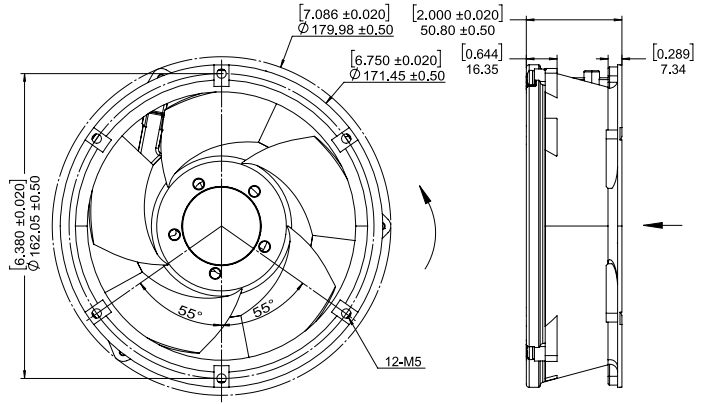

STANDARD FEATURES

- Size: 171.45 × 50.80 mm deep (6.75" × 2.00")
- Operating Temperature: -10 C to +70 C
- Storage Temperature: -40 C to +80 C
- Weight: 1.0 Kg (2.2 lbs)
- Dual Sealed Ball Bearings
- Die Cast Aluminum Venturi
- Propeller: UL94V-0 PBT
- 12" Lead Wires
- Environmental E2 encapsulated

BENEFITS

- High Pressure Mixed Flow Cooling with multiple configurations to meet customers needs
- Outstanding Airflow
- Expected Life of 75,000 Hours @ 40 C
- True Dependability With an 12 Month Warranty
- High Performance Competitively Priced Fan
- Designed with optional feature
 Speed control: Linear voltage, PWM, Thermal sensor
 Feedback: Tach , FPS
- UL 507 WET certified
- This fan is designed for continuous duty life of 72,000 Hours at 40 C (L10)

STANDARD FEATURES

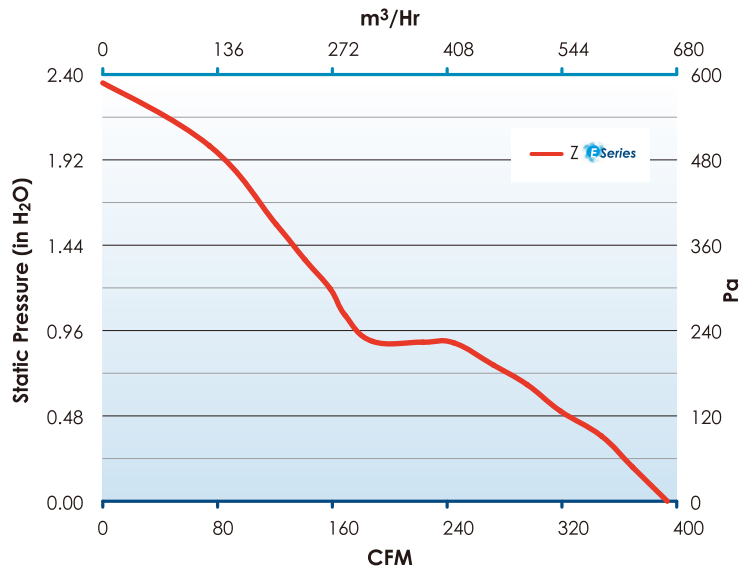

PARAMETER TABLE

Model Number	Part Number	Termination	Rated Voltage	Operating Voltage	Rated Current	Rated Input Power	Speed	Rated Air Flow		Rated Air Pressure		Noise
			VDC	VDC	Amps	Watts		CFM	m³/Hr	inch-H ₂ O	Pascal	
MFXE24Z6D3-E2	19044017A	Harness	24	16~32	3.10	74.4	5400	394	669.4	2.37	589	72.0
MFXE48Z6D3	19044012A	Harness	48	28~72	1.55	74.4	5400	394	669.4	2.37	589	72.0
MFXE24Z3D3-E2	19044019A	Leadwires	24	16~32	3.10	74.4	5400	394	669.4	2.37	589	72.0
MFXE48Z3D3-E2	19044018A	Leadwires	48	28~72	1.55	74.4	5400	394	669.4	2.37	589	72.0



Mixtus 7.9 DC

220×70mm E Series



MECHANICAL DRAWING

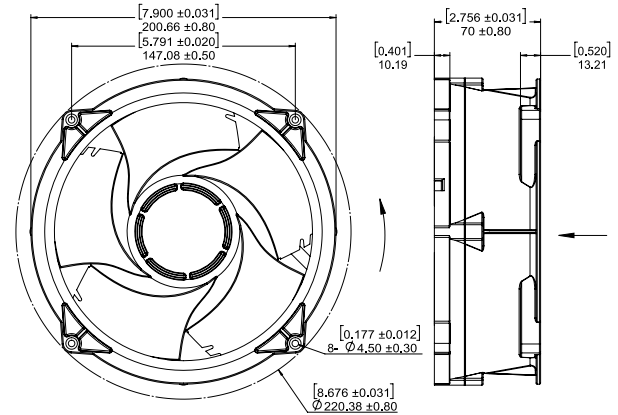

STANDARD FEATURES

- Size: 220.38 × 70.00 mm deep (8.68" × 2.76")
- Operating Temperature: -10 C to +70 C
- Storage Temperature: -40 C to +80 C
- Weight: 1.81 Kg (4.0 lbs)
- Dual Sealed Ball Bearings
- Die Cast Aluminum Venturi
- Propeller: UL94V-0 PBT
- 12" Lead Wires

BENEFITS

- High Pressure Mixed Flow Cooling with multiple configurations to meet customers needs
- Outstanding Airflow
- Expected Life of 70,000 Hours @ 40 C
- True Dependability With an 12 Month Warranty
- High Performance Competitively Priced Fan
- UL 507 WET certified
- This fan is designed for continuous duty life of 70,000 Hours at 40 C (L10)

STANDARD FEATURES

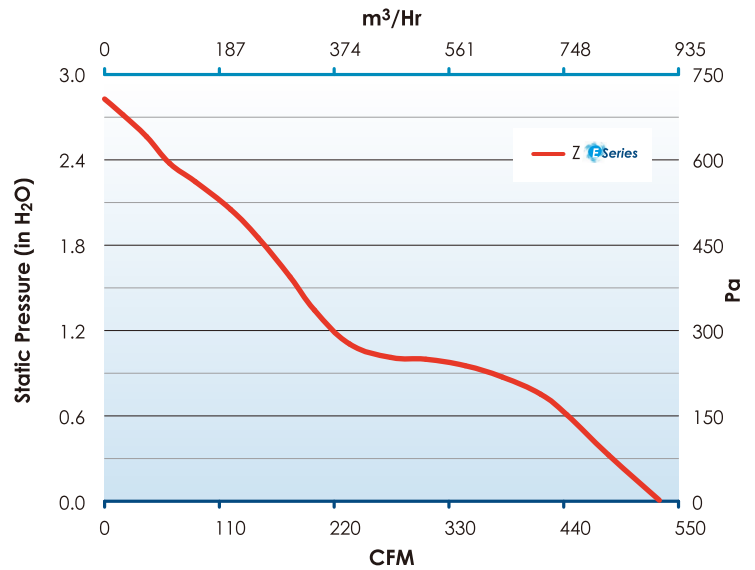

PARAMETER TABLE

Model Number	Part Number	Termination	Rated Voltage	Operating Voltage	Rated Current	Rated Input Power	Speed	Rated Air Flow		Rated Air Pressure		Noise
			VDC	VDC	Amps	Watts		RPM	CFM	m³/Hr	inch-H ₂ O	
MFSE24Z3	19044008A	Leadwires	24	16~32	4.5	108	4600	530	900.5	2.82	702	85.0
MFSE48Z3	19044009A	Leadwires	48	24~72	2.3	110	4600	530	900.5	2.82	702	85.0



Diplomat DD4021

118×55mm

MECHANICAL DRAWING

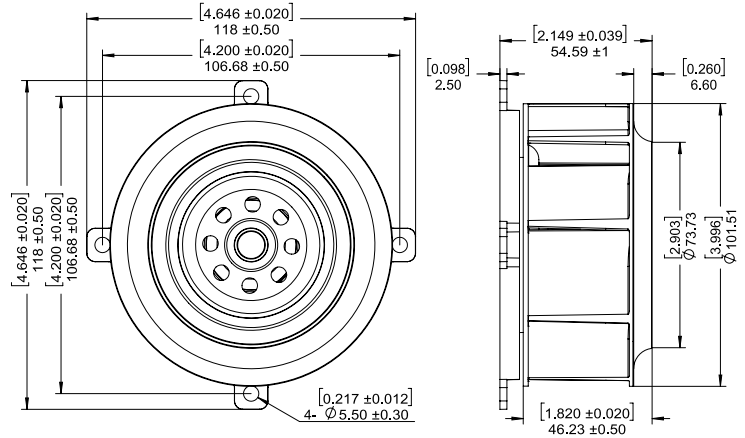

STANDARD FEATURES

- Size: 118.00 × 54.59 mm deep (4.65" × 2.15")
- Operating Temperature: -10 C to +70 C
- Storage Temperature: -40 C to +85 C
- Weight: 355 g (0.78 lbs)
- Dual Ball Bearings
- Impelldr: Polycarbonate, UL94V-0
- Motor base: Die Cast Aluminum
- 12" Lead Wires

BENEFITS

- Outstanding CFM Performance in High Pressure Systems
- Dependability with an 12 Month Warranty
- Extend Bearing Life
- Soft Start Capability
- Designed with optional feature
 Speed control: Linear voltage, PWM, Thermal sensor
 Feedback: Tach , FPS
- This fan is designed for continuous duty life of 52,000 Hours at 40 C (L10)

STANDARD FEATURES

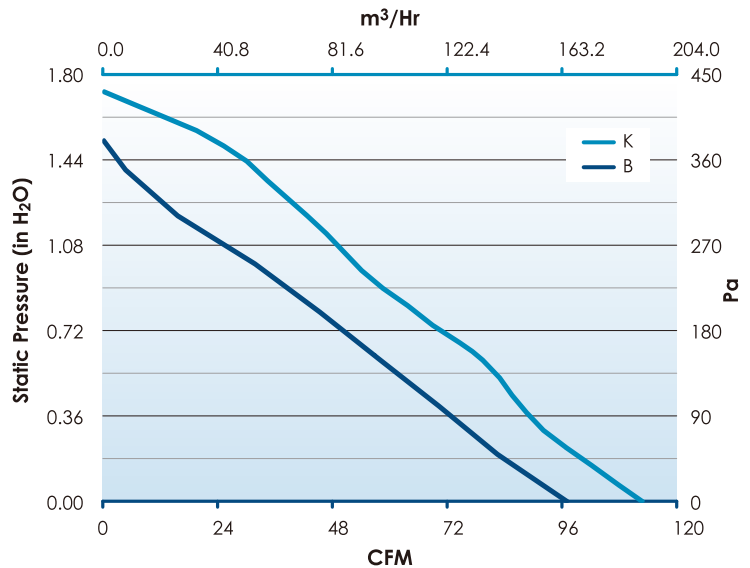

PARAMETER TABLE

Model Number	Part Number	Termination	Rated Voltage	Operating Voltage	Rated Current	Rated Input Power	Speed	Rated Air Flow		Rated Air Pressure		Noise
			VDC	VDC	Amps	Watts		CFM	m³/Hr	inch-H₂O	Pascal	
DD402112B1R	19039820A	Leadwires	12	7~15	1.75	21.0	5000	100	169.9	1.52	379	59.0
DD402124B1R	19039821A	Leadwires	24	12~32	0.92	22.1	5000	100	169.9	1.52	379	59.0
DD402148B1R	19039822A	Leadwires	48	24~72	0.38	18.2	5000	100	169.9	1.52	379	59.0
DD402112K1R	19039823A	Leadwires	12	7~15	2.75	33.0	5900	116	197.1	1.73	430	67.0
DD402124K1R	19039824A	Leadwires	24	12~32	1.33	31.9	5900	116	197.1	1.73	430	67.0
DD402148K1R	19039825A	Leadwires	48	24~72	0.72	34.6	5900	116	197.1	1.73	430	67.0



Diplomat DD6921

175×53mm



MECHANICAL DRAWING

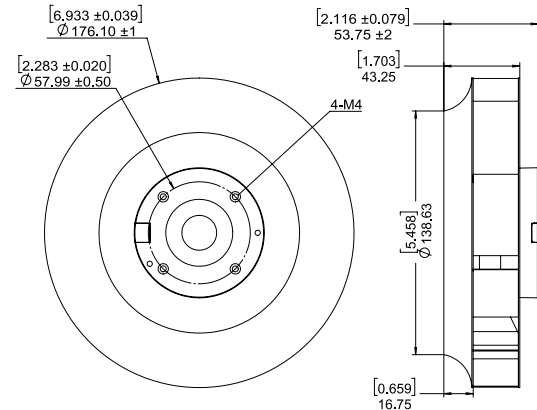

STANDARD FEATURES

- Size: 176.10 × 53.75 mm deep (6.93" × 2.11")
- Operating Temperature: -10 C to +70 C
- Storage Temperature: -40 C to +85 C
- Weight: 860 g (1.90 lbs)
- Dual Sealed Ball Bearings
- Impellor: Black Powder Coat
- Motor base: Die Cast Aluminum
- 12" Lead Wires

BENEFITS

- Outstanding CFM Performance in High Pressure Systems
- Dependability with an 12 Month Warranty
- Extend Bearing Life
- Soft Start Capability
- Designed with optional feature
Speed control: Linear voltage, PWM, Thermal sensor
Feedback: Tach , FPS
- This fan is designed for continuous duty life of 55,000 Hours at 40 C (L10)

STANDARD FEATURES

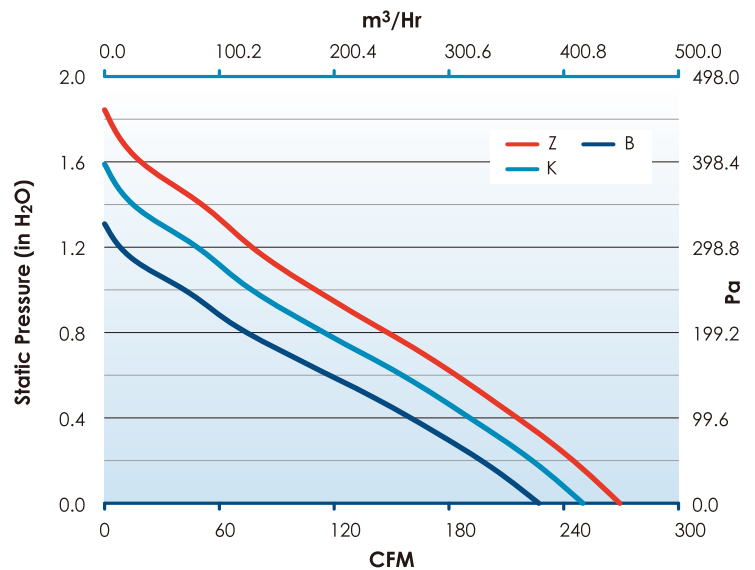

PARAMETER TABLE

Model Number	Part Number	Termination	Rated Voltage	Operating Voltage	Rated Current	Rated Input Power	Speed	Rated Air Flow		Rated Air Pressure		Noise
			VDC	VDC	Amps	Watts		RPM	CFM	m ³ /Hr	inch-H ₂ O	
DD692112B1A	17000276A	Leadwires	12	7~15	2.01	25.1	2950	227	385.8	1.31	326	65.1
DD692124B1A	17000277A	Leadwires	24	12~32	0.96	23.0	2950	227	385.8	1.31	326	65.1
DD692148B1A	17000278A	Leadwires	48	24~72	0.49	23.3	2950	227	385.8	1.31	326	65.1
DD692112K1A	19039841A	Leadwires	12	7~15	2.80	33.6	3250	250	424.8	1.59	396	67.2
DD692124K1A	19039842A	Leadwires	24	12~32	1.28	30.7	3250	250	424.8	1.59	396	67.2
DD692148K1A	19039843A	Leadwires	48	24~72	0.65	31.2	3250	250	424.8	1.59	396	67.2
DD692112Z1A	17000279A	Leadwires	12	7~15	3.50	42.0	3500	269	457.7	1.85	459	68.8
DD692124Z1A	17000280A	Leadwires	24	12~32	1.60	38.3	3500	269	457.7	1.85	459	68.8
DD692148Z1A	17000281A	Leadwires	48	24~72	0.81	39.0	3500	269	457.7	1.85	459	68.8



Diplomat DD6927

175×69mm

MECHANICAL DRAWING

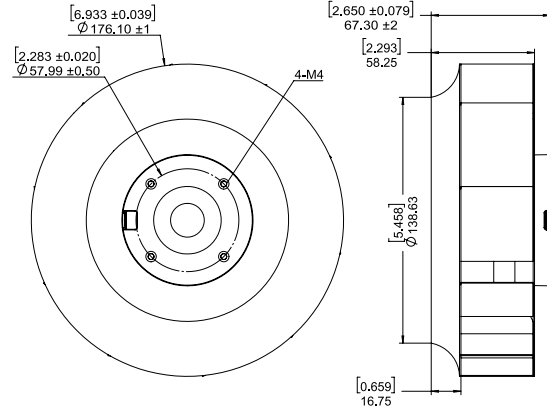

STANDARD FEATURES

- Size: 176.10 × 67.30 mm deep (6.93" × 2.65")
- Operating Temperature: -10 C to +70 C
- Storage Temperature: -40 C to +85 C
- Weight: 1.1 Kg (2.43 lbs)
- Dual Sealed Ball Bearings
- Impelldr: Black Powder Coat
- Motor base: Die Cast Aluminum
- 12" Lead Wires

BENEFITS

- Outstanding CFM Performance in High Pressure Systems
- Dependability with an 12 Month Warranty
- Extend Bearing Life
- Soft Start Capability
- Designed with optional feature
 Speed control: Linear voltage, PWM, Thermal sensor
 Feedback: Tach , FPS
- This fan is designed for continuous duty life of 55,000 Hours at 40 C (L10)

STANDARD FEATURES

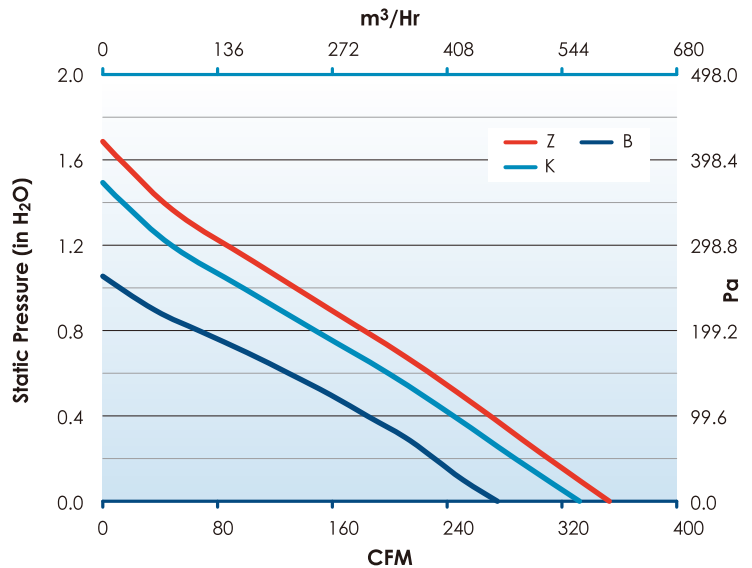

PARAMETER TABLE

Model Number	Part Number	Termination	Rated Voltage	Operating Voltage	Rated Current	Rated Input Power	Speed	Rated Air Flow		Rated Air Pressure		Noise
			VDC	VDC	Amps	Watts		CFM	m ³ /Hr	inch-H ₂ O	Pascal	
DD692712B1A	19039847A	Leadwires	12	7~15	2.70	32.4	2850	275	467.2	1.06	264	65.0
DD692724B1A	19039848A	Leadwires	24	12~32	1.27	30.5	2850	275	467.2	1.06	264	65.0
DD692748B1A	19039849A	Leadwires	48	24~72	0.67	32.2	2850	275	467.2	1.06	264	65.0
DD692712K1A	19039850A	Leadwires	12	7~15	4.70	56.4	3200	332	564.1	1.50	373	68.8
DD692724K1A	19039851A	Leadwires	24	12~32	1.87	44.9	3200	332	564.1	1.50	373	68.8
DD692748K1A	19039852A	Leadwires	48	24~72	0.94	45.1	3200	332	564.1	1.50	373	68.8
DD692712Z1A	17000282A	Leadwires	12	7~15	5.63	67.6	3400	353	600.0	1.69	422	70.1
DD692724Z1A	17000283A	Leadwires	24	12~32	2.25	53.8	3400	353	600.0	1.69	422	70.1
DD692748Z1A	17000284A	Leadwires	48	24~72	1.13	54.1	3400	353	600.0	1.69	422	70.1



Diplomat DD8928

227×71mm E Series

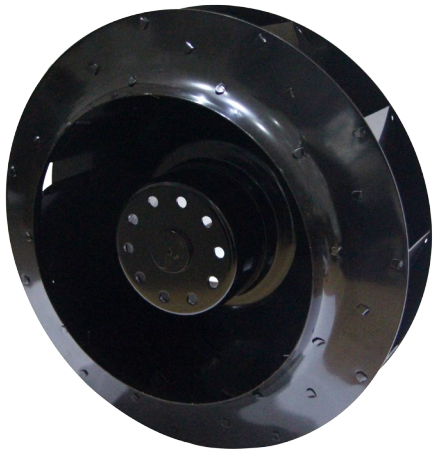

MECHANICAL DRAWING

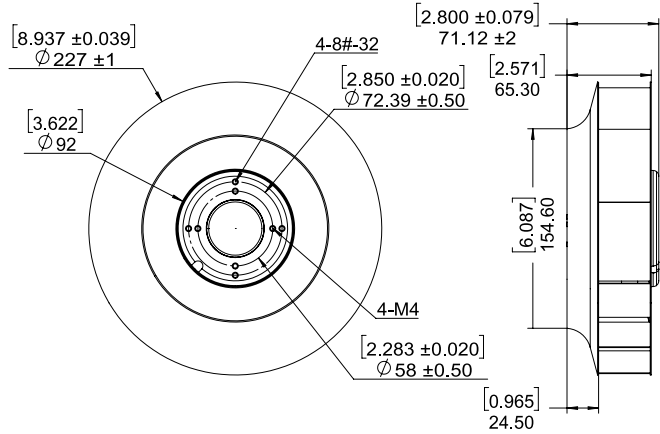

STANDARD FEATURES

- Size: 227.00 × 71.12 mm deep (8.94" × 2.80")
- Operating Temperature: -10 C to +70 C
- Storage Temperature: -40 C to +85 C
- Weight: 1.6 Kg (3.53 lbs)
- Dual Sealed Ball Bearings
- Impeller: Black Powder Coat
- Motor base: Die Cast Aluminum
- 12" Lead Wires

BENEFITS

- Outstanding CFM Performance in High Pressure Systems
- Dependability with an 12 Month Warranty
- Extend Bearing Life
- Soft Start Capability
- Designed with optional feature
Speed control: Linear voltage, PWM, Thermal sensor
Feedback: Tach , FPS
- This fan is designed for continuous duty life of 48,000 Hours at 40 C (L10)

E Products developed with new E-Series technology delivering higher performance, efficiency, and expanded feature sets.

STANDARD FEATURES

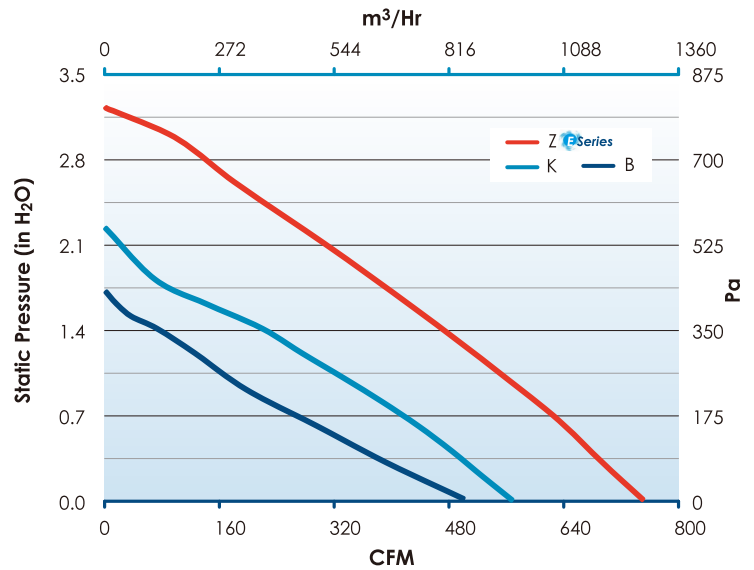

PARAMETER TABLE

Model Number	Part Number	Termination	Rated Voltage	Operating Voltage	Rated Current	Rated Input Power	Speed	Rated Air Flow		Rated Air Pressure		Noise
			VDC	VDC	Amps	Watts		CFM	m ³ /Hr	inch-H ₂ O	Pascal	
DD892824B1A	19039864A	Leadwires	24	12~32	2.65	63.6	2600	500	849.5	1.70	423	72.5
DD892848B1A	19039865A	Leadwires	48	24~72	1.40	67.2	2600	500	849.5	1.70	423	72.5
DD892824K1A	19039866A	Leadwires	24	12~32	4.20	100.8	2800	565	959.9	2.22	553	75.0
DD892848K1A	19039867A	Leadwires	48	24~72	2.10	100.8	2800	565	959.9	2.22	553	75.0
DD892824Z1E	19041012A	Leadwires	24	12~32	5.20	124.8	3500	750	1274.3	3.22	802	78.7
DD892848Z1E	19041015A	Leadwires	48	24~72	2.60	124.8	3500	750	1274.3	3.22	802	78.7



Diplomat DD8939

227×99mm E Series

MECHANICAL DRAWING

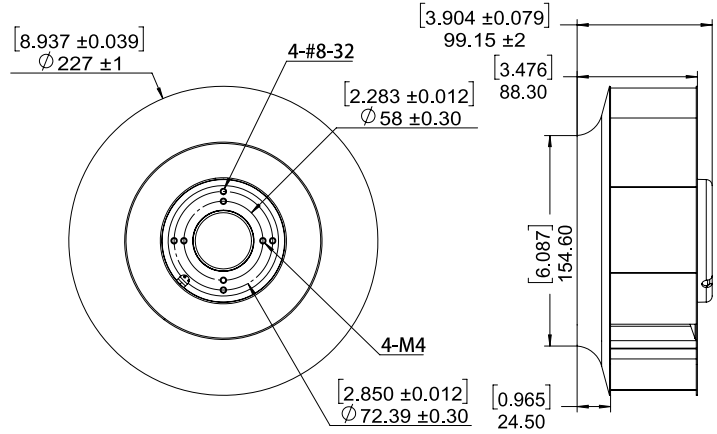

STANDARD FEATURES

- Size: 227.00 × 99.15 mm deep (8.90" × 3.90")
- Operating Temperature: -10 C to +70 C
- Storage Temperature: -40 C to +85 C
- Weight: 1.7 Kg (3.75 lbs)
- Dual Sealed Ball Bearings
- Impelldr: Black Powder Coat
- Motor base: Die Cast Aluminum
- 12" Lead Wires

BENEFITS

- Outstanding CFM Performance in High Pressure Systems
- Dependability with an 12 Month Warranty
- Extend Bearing Life
- Soft Start Capability
- Designed with optional feature
 Speed control: Linear voltage, PWM, Thermal sensor
 Feedback: Tach , FPS
- This fan is designed for continuous duty life of 48,000 Hours at 40 C (L10)

STANDARD FEATURES

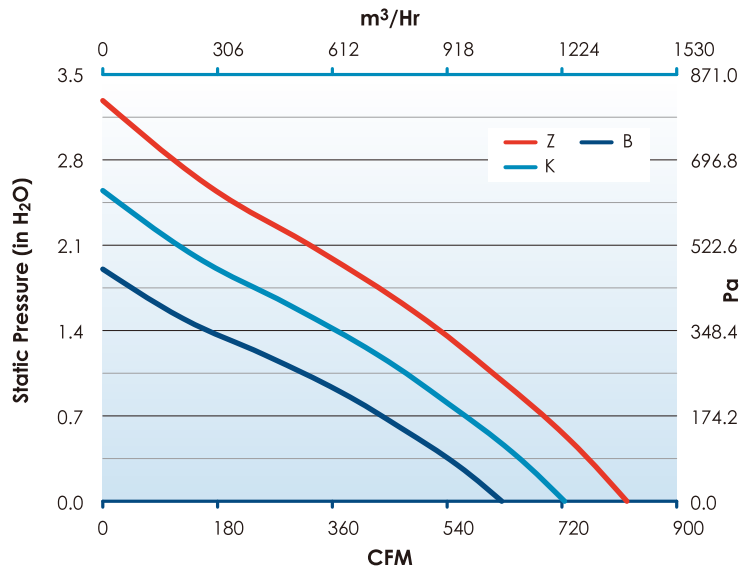

E Products developed with new E-Series technology delivering higher performance, efficiency, and expanded feature sets.



PARAMETER TABLE

Model Number	Part Number	Termination	Rated Voltage	Operating Voltage	Rated Current	Rated Input Power	Speed	Rated Air Flow		Rated Air Pressure		Noise
			VDC	VDC	Amps	Watts		CFM	m³/Hr	inch-H ₂ O	Pascal	
DD893924B1A	19039870A	Leadwires	24	12~32	3.5	84.0	2550	626	1063.6	1.90	474	73.5
DD893948B1A	19039871A	Leadwires	48	24~72	2.1	100.0	2550	626	1063.6	1.90	474	73.5
DD893924K1A	17000285A	Leadwires	24	12~32	5.4	130.1	2950	724	1230.9	2.55	635	76.7
DD893948K1A	17000286A	Leadwires	48	24~72	3.2	154.8	2950	724	1230.9	2.55	635	76.7
DD893924Z1E	19040988A	Leadwires	24	12~32	7.9	190.5	3350	822	1297.8	3.29	818	79.4
DD893948Z1E	19040991A	Leadwires	48	24~72	4.7	225.6	3350	822	1297.8	3.29	818	79.4

Diplomat DDE1149

281×125mm E Series



MECHANICAL DRAWING

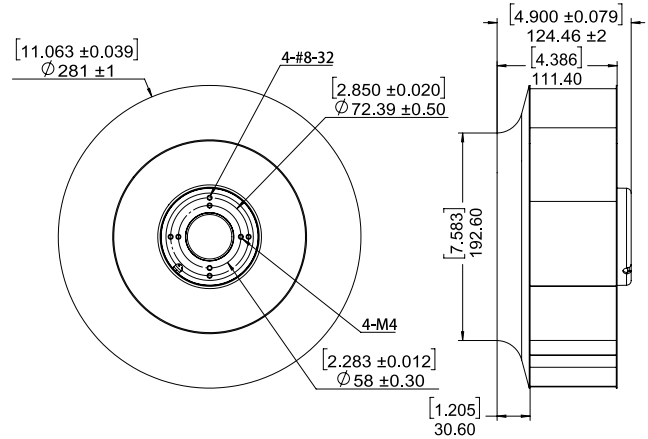

STANDARD FEATURES

- Size: 281.00 × 124.46 mm deep (11.0" × 4.9")
- Operating Temperature: -10 C to +70 C
- Storage Temperature: -40 C to +85 C
- Weight: 2.5 Kg (5.52 lbs)
- Dual Sealed Ball Bearings
- Impellor: Black Powder Coat
- Motor base: Die Cast Aluminum
- 12" Lead Wires

BENEFITS

- Outstanding CFM Performance in High Pressure Systems
- Dependability with an 12 Month Warranty
- Extend Bearing Life
- Soft Start Capability
- Designed with optional feature
Speed control: Linear voltage, PWM, Thermal sensor
Feedback: Tach , FPS
- This fan is designed for continuous duty life of 42,000 Hours at 40 C (L10)

STANDARD FEATURES

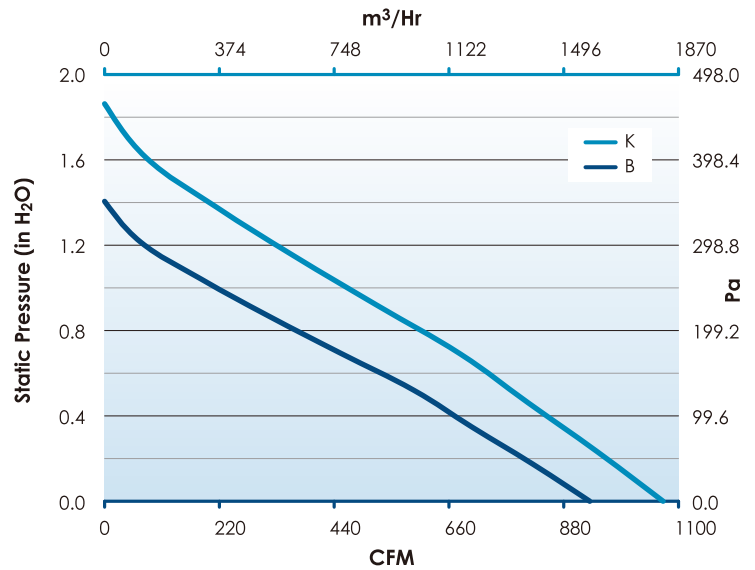

E Products developed with new E-Series technology delivering higher performance, efficiency, and expanded feature sets.



PARAMETER TABLE

Model Number	Part Number	Termination	Rated Voltage	Operating Voltage	Rated Current	Rated Input Power	Speed	Rated Air Flow		Rated Air Pressure		Noise
			VDC	VDC	Amps	Watts		RPM	CFM	m ³ /Hr	inch-H ₂ O	
DDE114924B1E	17000266A	Leadwires	24	12~32	4.9	117.6	1650	930	1581	1.4	350	79.4
DDE114948B1E	17000267A	Leadwires	48	24~72	2.4	115.0	1650	930	1581	1.4	350	79.4
DDE114924K1E	19040962A	Leadwires	24	12~32	5.2	125.0	1900	1070	1818	1.86	463	78.0
DDE114948K1E	19040965A	Leadwires	48	24~72	2.6	125.0	1900	1070	1818	1.86	463	78.0

80×32mm 80mm Blower

MECHANICAL DRAWING

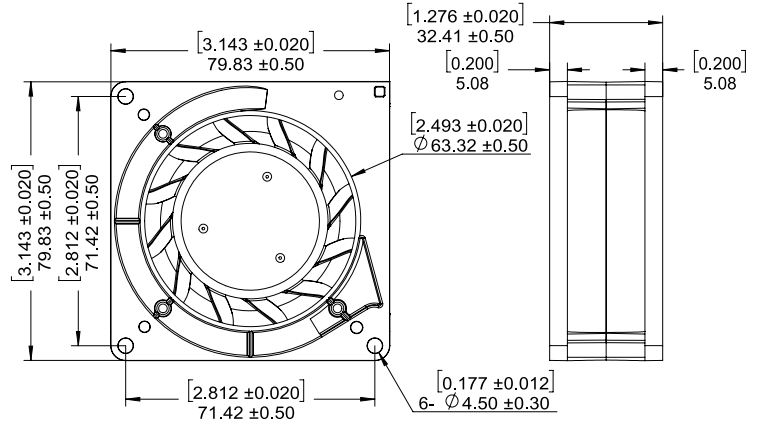

STANDARD FEATURES

- Size: 79.83 × 32.41 mm deep (3.14" × 1.28")
- Operating Temperature: -10 C to +70 C
- Storage Temperature: -40 C to +85 C
- Weight: 190 g (6.7 oz)
- Dual Ball Bearings
- Impeller: Plastic
- Venturi: Plastic
- 12" Lead Wires

BENEFITS

- Outstanding CFM Performance in High Pressure Systems
- Dependability with an 12 Month Warranty
- Extend Bearing Life
- Designed with optional feature
 Speed control: Linear voltage, PWM, Thermal sensor
 Feedback: Tach , FPS
- This fan is designed for continuous duty life of 55,000 Hours at 70 C (L10)

STANDARD FEATURES

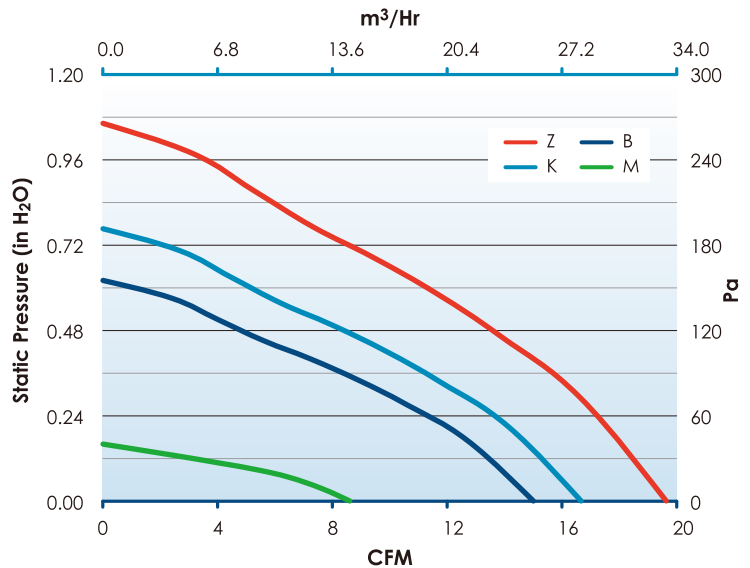

PARAMETER TABLE

Model Number	Part Number	Termination	Rated Voltage	Operating Voltage	Rated Current	Rated Input Power	Speed	Rated Air Flow		Rated Air Pressure		Noise
			VDC	VDC	Amps	Watts		RPM	CFM	m³/Hr	inch-H₂O	
WT12M3	19031103A	Leadwires	12	6~14	0.09	1.1	2300	8.6	14.6	0.16	40	36.0
WT24M3	19031104A	Leadwires	24	12~28	0.06	1.4	2300	8.6	14.6	0.16	40	36.0
WT12B3	19031101A	Leadwires	12	6~14	0.42	5.0	4050	15.0	25.5	0.62	154	51.4
WT24B3	19031102A	Leadwires	24	12~28	0.20	4.8	4050	15.0	25.5	0.62	154	51.4
WT48B3	17000287A	Leadwires	48	24~56	0.11	5.3	4050	15.0	25.5	0.62	154	51.4
WT12K3	17000023A	Leadwires	12	6~14	0.55	6.6	4500	16.7	28.4	0.77	191	53.7
WT24K3	17000024A	Leadwires	24	12~28	0.27	6.4	4500	16.7	28.4	0.77	191	53.7
WT12Z3	19040713A	Leadwires	12	6~14	0.90	10.8	5300	19.6	33.3	1.06	264	57.3
WT24Z3	19031544A	Leadwires	24	12~28	0.43	10.3	5300	19.6	33.3	1.06	264	57.3



MECHANICAL DRAWING

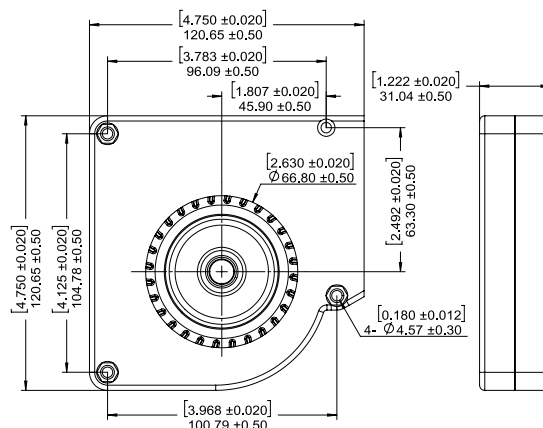

STANDARD FEATURES

- Size: 120.65 × 31.04 mm deep (4.75" × 1.22")
- Operating Temperature: -10 C to +70 C
- Storage Temperature: -40 C to +85 C
- Weight: 280 g (9.9 oz)
- Dual Ball Bearings
- Impeller: Glass Filled Nylon
- Venturi: Polypropylene
- 12" Lead Wires

BENEFITS

- Outstanding CFM Performance in High Pressure Systems
- Dependability with an 12 Month Warranty
- Extend Bearing Life
- Designed with optional feature
Speed control: Linear voltage, PWM, Thermal sensor
Feedback: Tach , FPS
- This fan is designed for continuous duty life of 52,000 Hours at 70 C (L10)

STANDARD FEATURES

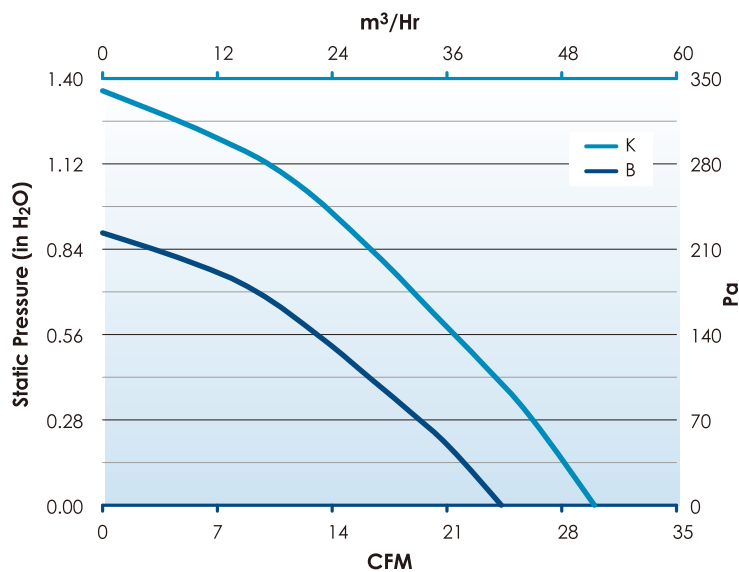

PARAMETER TABLE

Model Number	Part Number	Termination	Rated Voltage	Operating Voltage	Rated Current	Rated Input Power	Speed	Rated Air Flow		Rated Air Pressure		Noise
			VDC	VDC	Amps	Watts		CFM	m³/Hr	inch-H ₂ O	Pascal	
BD12B3	19030619A	Leadwires	12	6~14	0.90	10.8	3040	26	44.2	0.87	217	51.2
BD24B3	19030621A	Leadwires	24	12~28	0.48	11.5	3040	26	44.2	0.87	217	51.2
BD48B3	19030637A	Leadwires	48	24~56	0.25	12.0	3040	26	44.2	0.87	217	51.2
BD12K3	17000025A	Leadwires	12	6~14	1.40	16.8	3750	30	51.0	1.36	339	53.5
BD24K3	19039220A	Leadwires	24	12~28	0.66	15.8	3750	30	51.0	1.36	339	53.5
BD48K3	19039239A	Leadwires	48	24~56	0.28	13.4	3750	30	51.0	1.36	339	53.5



Spinnaker DC

161×51mm 160mm Blower

MECHANICAL DRAWING

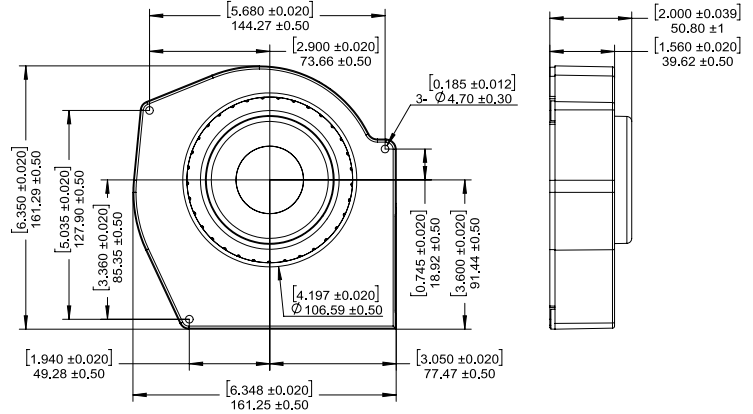

STANDARD FEATURES

- Size: 161.29 × 50.80 mm deep (6.35" × 2.00")
- Operating Temperature: -10 C to +70 C
- Storage Temperature: -40 C to +85 C
- Weight: 950 g (2.1 lbs)
- Dual Ball Bearings
- Impeller: Polycarbonate
- Venturi: Polycarbonate
- Optional Aluminum Mounting Base Plate
- 12" Lead Wires

BENEFITS

- Outstanding CFM Performance in High Pressure Systems
- Dependability with an 12 Month Warranty
- Extend Bearing Life
- Designed with optional feature
 Speed control: Linear voltage, PWM, Thermal sensor
 Feedback: Tach , FPS
- This fan is designed for continuous duty life
 of 45,000 Hours at 70 C (L10)

STANDARD FEATURES

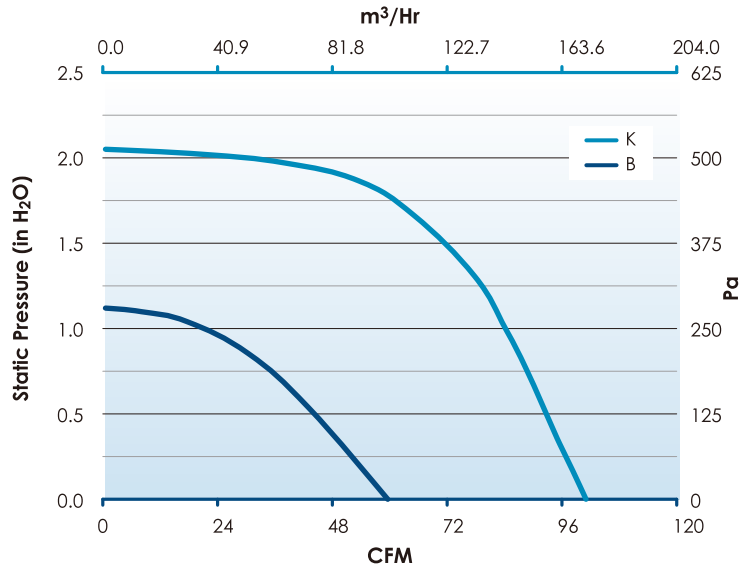

PARAMETER TABLE

Model Number	Part Number	Termination	Rated Voltage	Operating Voltage	Rated Current	Rated Input Power	Speed	Rated Air Flow		Rated Air Pressure		Noise
			VDC	VDC	Amps	Watts		RPM	CFM	m³/Hr	inch-H ₂ O	
SPD12B1	19032572A	Leadwires	12	6~14	2.20	26.4	2500	59	100.2	1.10	247	57.0
SPD24B1	19032183A	Leadwires	24	12~28	1.25	30.0	2500	59	100.2	1.10	247	57.0
SPD48B1	19032196A	Leadwires	48	24~56	0.53	25.4	2500	59	100.2	1.10	247	57.0
SPDD12K1	17000301A	Leadwires	12	6~14	6.30	75.3	4000	100.5	171	2.05	510	67.2
SPDD24K1	17000302A	Leadwires	24	12~28	3.14	75.3	4000	100.5	171	2.05	510	67.2
SPDD48K1	17000303A	Leadwires	48	24~56	1.58	75.3	4000	100.5	171	2.05	510	67.2



Sprite AC

80×38mm High Pressure



MECHANICAL DRAWING

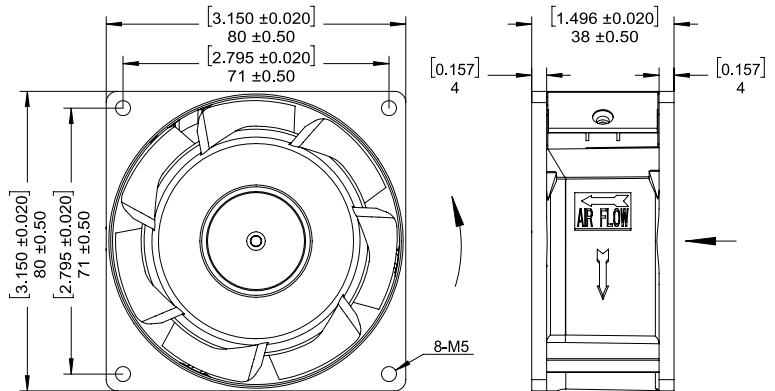

STANDARD FEATURES

- Size: 80.00 × 38.00 mm deep (3.15" × 1.45")
- Operating Temperature: -10 C to +70 C
- Storage Temperature: -40 C to +85 C
- Weight: 260 g (9.17 oz)
- Ball Bearings
- Impeller: Polypropylene
- Venturi: Metal Alloy
- 12" Lead Wires
- 50/60 Hz Operational

BENEFITS

- Outstanding CFM Performance in High Pressure Systems
- Dependability with an 12 Month Warranty
- Extend Bearing Life
- Quite
- Available terminals and custom lead lengths
- This fan is designed for continuous duty life of 62,000 Hours at 70 C (L10)

STANDARD FEATURES

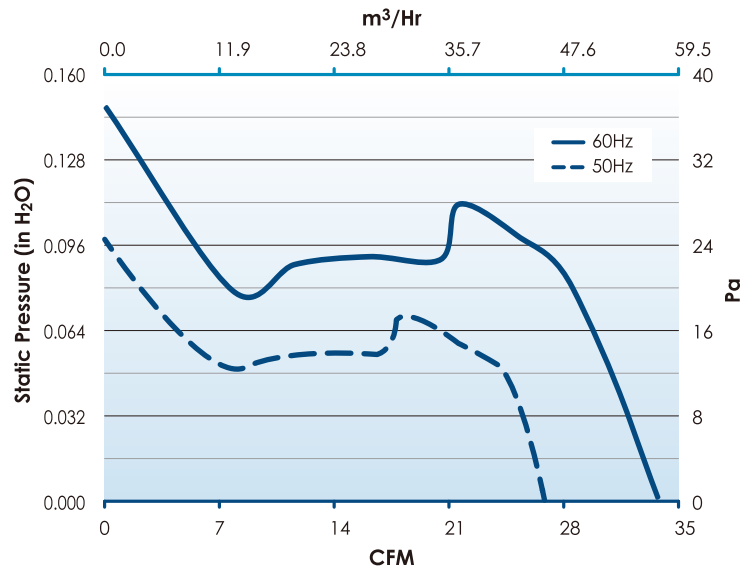

PARAMETER TABLE

Model Number	Part Number	Termination	Rated Voltage	Frequency	Rated Current	Rated Input Power	Speed	Rated Air Flow		Rated Air Pressure		Noise
			VAC	Hz	Amps	Watts	RPM	CFM	m ³ /Hr	inch-H ₂ O	Pascal	
SU2B1	19028268A	Leadwires	115	50/60	0.19/0.15	13/11	2750/3250	26.5/34	45/59	0.10/0.15	25/37	35/41
SU3B1	19028331A	Leadwires	220/230	50/60	0.09/0.08	14/13	2750/3250	26.5/34	45/59	0.10/0.15	25/37	35/41



Muffin XL AC

120×38mm

MECHANICAL DRAWING

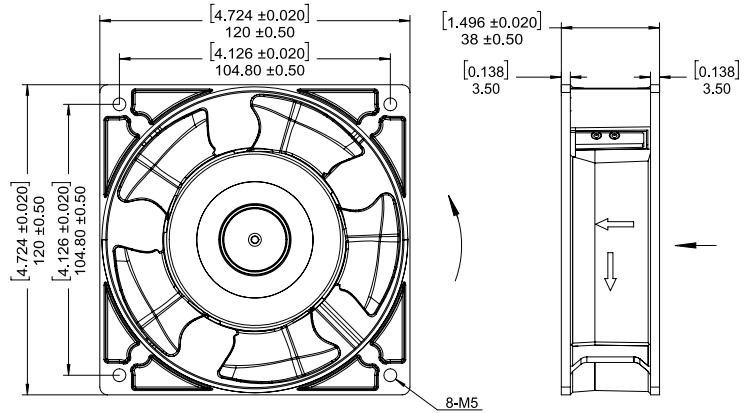

STANDARD FEATURES

- Size: 120.00 × 38.00 mm deep (4.72" × 1.50")
- Operating Temperature: -10 C to +70 C
- Storage Temperature: -40 C to +85 C
- Weight: 450 g (15.87 oz)
- Dual Ball Bearings
- Impeller: Polypropylene
- Venturi: Aluminum
- 0.120" Terminals
- 50/60 Hz Operational

BENEFITS

- Outstanding CFM Performance in High Pressure Systems
- Dependability with an 12 Month Warranty
- Extend Bearing Life
- Designed with optional performance features
- Available custom lead lengths
- This fan is designed for continuous duty life of 55,000 Hours at 70 C (L10)

STANDARD FEATURES

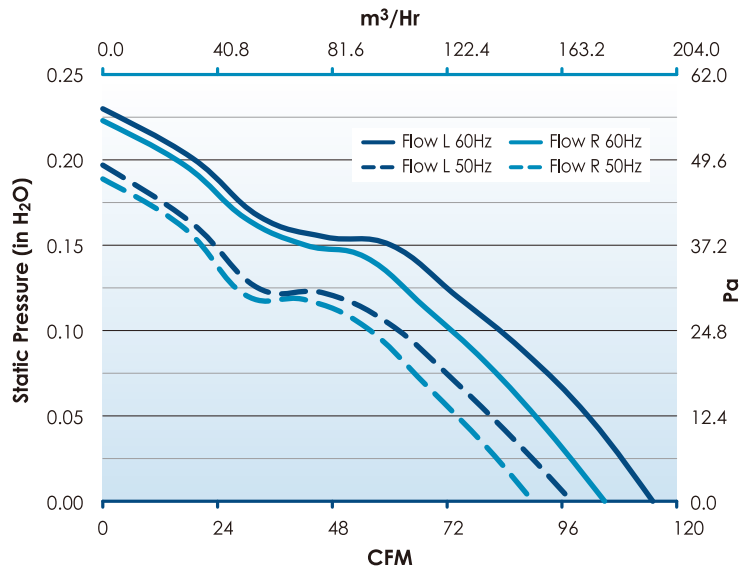

PARAMETER TABLE

Model Number	Part Number	Termination	Flow Direction	Rated Voltage	Frequency	Rated Current	Rated Input Power	Speed	Rated Air Flow	Rated Air Pressure	Noise		
				VAC	Hz	Amps	Watts	RPM	CFM	m ³ /Hr		inch-H ₂ O	Pascal
MX2B1	19028420A	Terminals	Right	115	50/60	0.20/0.18	17/15	2700/3100	90/105	153/178	0.19/0.22	47/55	43.4/51.0
MX3B1	19028421A	Terminals	Right	220/230	50/60	0.10/0.09	17/16	2700/3100	90/105	153/178	0.19/0.22	47/55	43.4/51.0
MX2B3	19028422A	Terminals	Left	115	50/60	0.20/0.18	17/15	2700/3100	98/115	167/196	0.20/0.23	49/57	46.3/54.3
MX3B3	19028423A	Terminals	Left	220/230	50/60	0.10/0.09	17/16	2700/3100	98/115	167/196	0.20/0.23	49/57	46.3/54.3



Major AC

172×150×51mm



MECHANICAL DRAWING

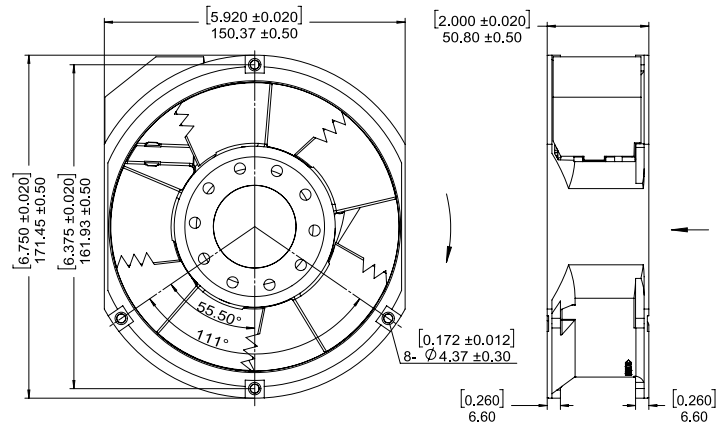

STANDARD FEATURES

- Size: 171.45 × 150.37 × 50.80 mm deep (6.75" × 5.92" × 2.00")
- Operating Temperature: -10 C to +70 C
- Storage Temperature: -40 C to +85 C
- Weight: 840 g (1.85 lbs)
- Dual Ball Bearings
- Impeller: Polycarbonate
- Venturi: Metal Alloy
- 0.110" Terminals
- 50/60 Hz Operational

BENEFITS

- Outstanding CFM Performance in High Pressure Systems
- Dependability with an 12 Month Warranty
- Extend Bearing Life
- Designed with AC FPS option
- Available custom lead lengths
- Thermal Protection
- This fan is designed for continuous duty life of 62,000 Hours at 40 C (L10)

STANDARD FEATURES

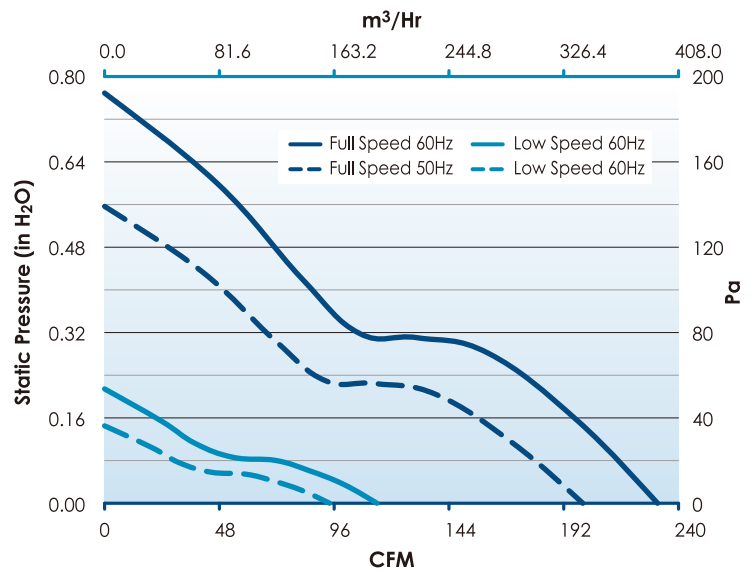

PARAMETER TABLE

Model Number	Part Number	Termination	Rated Voltage	Ferquency	Rated Current	Rated Input Power	Speed	Rated Air Flow	Rated Air Pressure	Noise		
			VAC	Hz	Amps	Watts	RPM	CFM	m ³ /Hr	inch-H ₂ O	Pascal	dB(A)
MR2B3	19028245A	Terminals	115	50/60	0.27/0.26	30/31	2850/3350	200/235	340/392	0.56/0.77	139/191	52.2/55/8
MR77B3	19028309A	Terminals	220/230	50/60	0.13/0.14	26/30	2850/3350	200/235	340/392	0.56/0.77	139/191	52.2/55/8
MR2D3	19032118A	Terminals	115	50/60	0.17/0.15	18/16	1400/1700	94/114	160/193	0.15/0.21	36/53	35.1/39.2
MR77D3	19032212A	Terminals	220/230	50/60	0.09/0.08	16/15	1400/1700	94/114	160/193	0.15/0.21	36/53	35.1/39.2



Patriot AC

172×51mm

MECHANICAL DRAWING

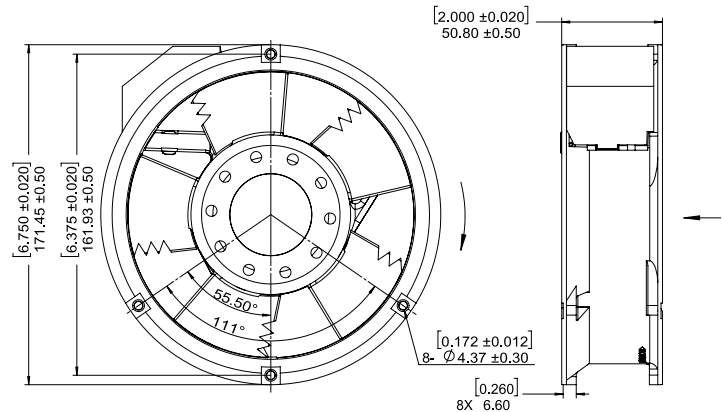

STANDARD FEATURES

- Size: 171.45 × 50.80 mm deep (6.75" × 2.00")
- Operating Temperature: -10°C to +70°C
- Storage Temperature: -40°C to +85°C
- Weight: 840 g (1.85 lbs)
- Dual Ball Bearings
- Impeller: Polycarbonate
- Venturi: Metal Alloy
- 0.110" Terminals
- 50/60 Hz Operational

BENEFITS

- Outstanding CFM Performance in High Pressure Systems
- Dependability with an 12 Month Warranty
- Extend Bearing Life
- Designed with optional performance features
- Available custom lead lengths
- Thermal Protection
- This fan is designed for continuous duty life of 62,000 Hours at 40°C (L10)

STANDARD FEATURES

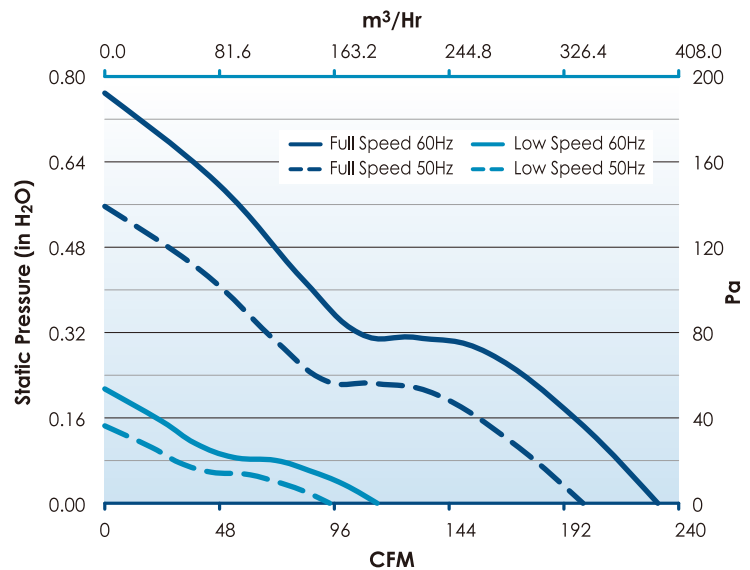

PARAMETER TABLE

Model Number	Part Number	Termination	Rated Voltage	Frequency	Rated Current	Rated Input Power	Speed	Rated Air Flow		Rated Air Pressure		Noise
			VAC	Hz	Amps	Watts	RPM	CFM	m ³ /Hr	inch-H ₂ O	Pascal	
PT2B3	19028254A	Terminals	115	50/60	0.27/0.26	30/31	2850/3350	200/235	340/392	0.56/0.77	139/191	50.3/54.0
PT77B3	19028312A	Terminals	220/230	50/60	0.13/0.14	26/30	2850/3350	200/235	340/392	0.56/0.77	139/191	50.3/54.0
PT2D3	19032213A	Terminals	115	50/60	0.17/0.15	18/16	1400/1700	94/114	160/193	0.15/0.21	36/53	34.5/37.5
PT77D3	19032214A	Terminals	220/230	50/60	0.09/0.08	16/15	1400/1700	94/114	160/193	0.15/0.21	36/53	34.5/37.5



Maltese AC

172×150×55mm



MECHANICAL DRAWING

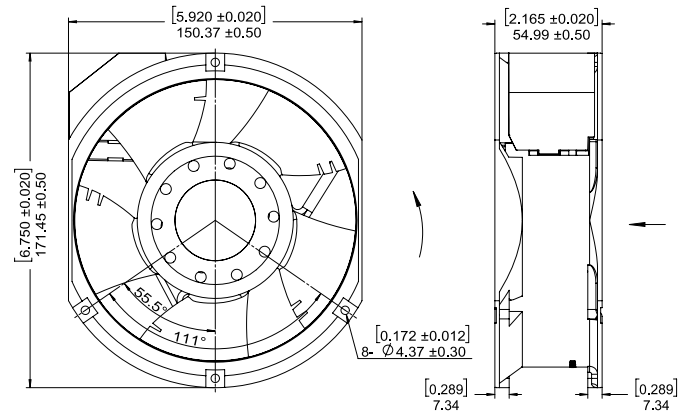

STANDARD FEATURES

- Size: 171.45 × 150.37 × 54.99 mm deep (6.75" × 5.92" × 2.17")
- Operating Temperature: -10 C to +70 C
- Storage Temperature: -40 C to +85 C
- Weight: 1 Kg (2.20 lbs)
- Dual Ball Bearings
- Impeller: Polycarbonate
- Venturi: Metal Alloy
- 0.110" Terminals
- 50/60 Hz Operational

BENEFITS

- Outstanding CFM Performance in High Pressure Systems
- Dependability with an 12 Month Warranty
- Extend Bearing Life
- Designed with AC FPS option
- Available custom lead lengths
- Thermal Protection
- This fan is designed for continuous duty life of 55,000 Hours at 40 C (L10)

STANDARD FEATURES

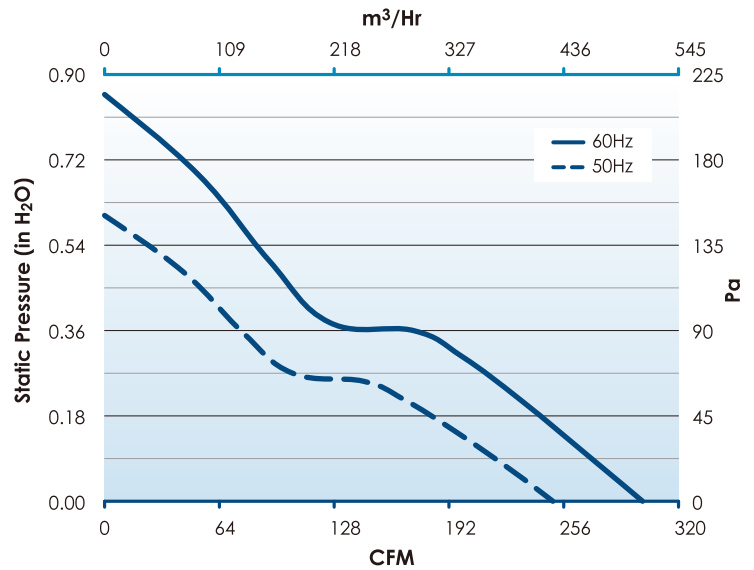

PARAMETER TABLE

Model Number	Part Number	Termination	Rated Voltage	Frequency	Rated Current	Rated Input Power	Speed	Rated Air Flow		Rated Air Pressure		Noise
			VAC	Hz	Amps	Watts	RPM	CFM	m³/Hr	inch-H₂O	Pascal	dB(A)
MA2B3	19031842A	Terminals	115	50/60	0.33/0.36	40.5/41.4	2850/3400	250/300	425/509	0.60/0.86	150/214	54.8/56.5
MA77B3	19031844A	Terminals	220/230	50/60	0.20/0.18	40.5/41.4	2850/3400	250/300	425/509	0.60/0.86	150/214	54.8/56.5



Tarzan AC

176×107mm

MECHANICAL DRAWING

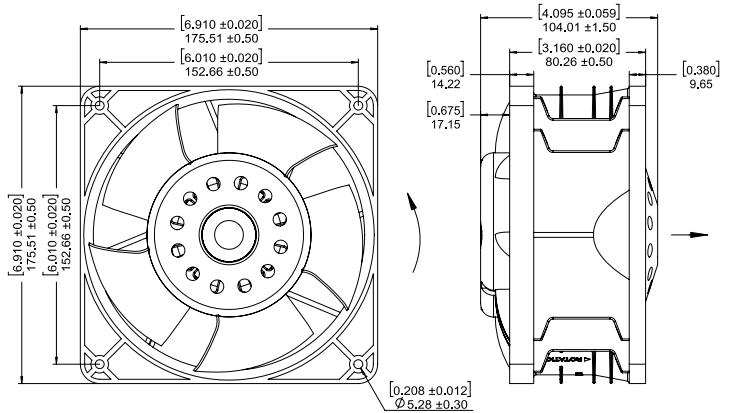

STANDARD FEATURES

- Size: 175.51 × 104.01 mm deep (6.91" × 4.10")
- Operating Temperature: -10°C to +70°C
- Storage Temperature: -40°C to +85°C
- Weight: 2.26 Kg (5 lbs)
- Ball Bearings
- Impeller: Polypropylene
- Venturi: Phenolic
- 12" Lead Wires or 2 Solder Terminals
- 50/60 Hz Operational

BENEFITS

- Outstanding CFM Performance in High Pressure Systems
- Dependability with an 12 Month Warranty
- Extend Bearing Life
- Available custom lead lengths
- This fan is designed for continuous duty life of 45,000 Hours at 60°C (L10)

STANDARD FEATURES

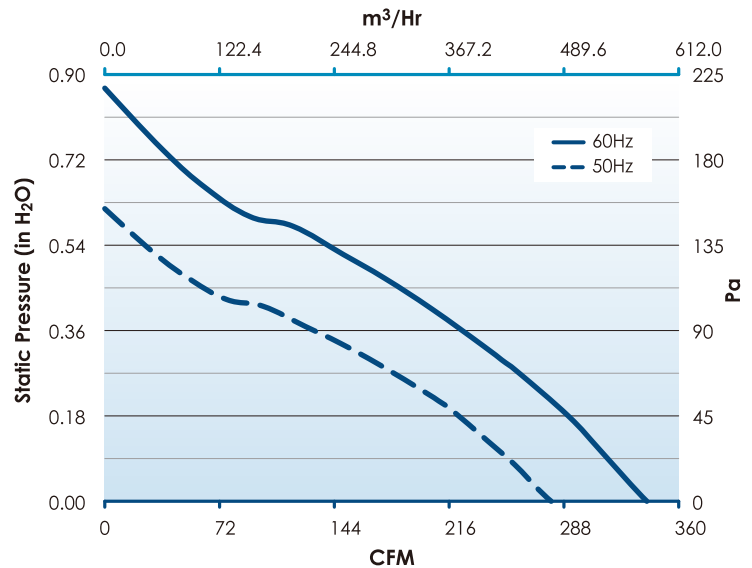

PARAMETER TABLE

Model Number	Part Number	Termination	Rated Voltage VAC	Frequency Hz	Rated Current Amps	Rated Input Power Watts	Speed RPM	Rated Air Flow CFM	Rated Air Flow m ³ /Hr	Rated Air Pressure inch-H ₂ O	Rated Air Pressure Pascal	Noise dB(A)
TNE2C	19020169A	Leadwires	115	50/60	0.45/0.49	48/59	2820/3350	280/340	476/578	0.62/0.87	154/217	61.6/65.4
TNE2A	19020174A	Terminals	115	50/60	0.45/0.49	48/59	2820/3350	280/340	476/578	0.62/0.87	154/217	61.6/65.4
TNE3C	19020177A	Leadwires	220/230	50/60	0.22/0.25	52/59	2820/3350	280/340	476/578	0.62/0.87	154/217	61.6/65.4
TNE3A	19020172A	Terminals	220/230	50/60	0.22/0.25	52/59	2820/3350	280/340	476/578	0.62/0.87	154/217	61.6/65.4

Caravel AC

254×89mm



MECHANICAL DRAWING

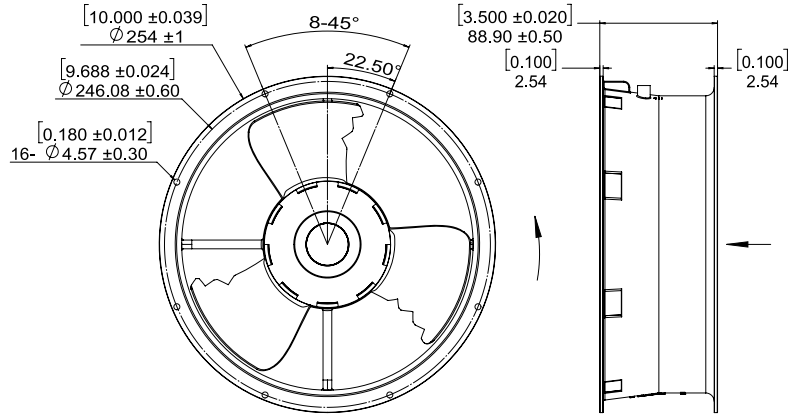

STANDARD FEATURES

- Size: 254.00 × 88.90 mm deep (10.00" × 3.50")
- Operating Temperature: -10 C to +70 C
- Storage Temperature: -40 C to +85 C
- Weight: 2 Kg (4.4 lbs)
- Dual Ball Bearings
- Impeller: Polycarbonate
- Venturi: Metal Alloy
- 12" Lead Wires or 2 Solder Terminals
- 50/60 Hz Operational

BENEFITS

- Outstanding CFM Performance in High Pressure Systems
- Dependability with an 12 Month Warranty
- Extend Bearing Life
- Designed with optional performance features
- Available custom lead lengths
- This fan is designed for continuous duty life of 46,000 Hours at 70 C (L10)

STANDARD FEATURES

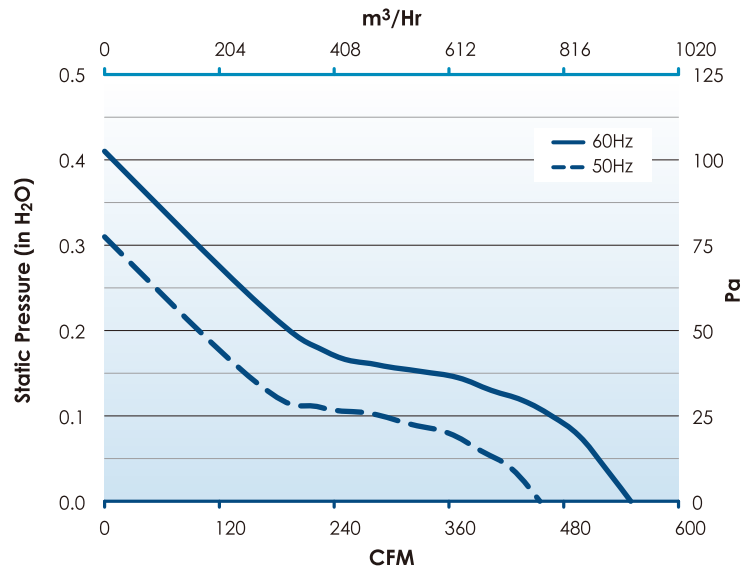

PARAMETER TABLE

Model Number	Part Number	Termination	Rated Voltage	Frequency	Rated Current	Rated Input Power	Speed	Rated Air Flow		Rated Air Pressure		Noise
			VAC	Hz	Amps	Watts		RPM	CFM	m ³ /Hr	inch-H ₂ O	
CLE2L2	19020188A	Leadwires	115	50/60	0.48/0.50	67/61	1400/1650	455/550	774/935	0.31/0.41	77/102	45.4/49.2
CLE2T2	19020189A	Terminals	115	50/60	0.48/0.50	67/61	1400/1650	455/550	774/935	0.31/0.41	77/102	45.4/49.2
CLE3L2	19020190A	Leadwires	230	50/60	0.24/0.25	60/60	1400/1650	455/550	774/935	0.31/0.41	77/102	45.4/49.2
CLE3T2	19020191A	Terminals	230	50/60	0.24/0.25	60/60	1400/1650	455/550	774/935	0.31/0.41	77/102	45.4/49.2



Caravel XL AC

254×107mm

MECHANICAL DRAWING

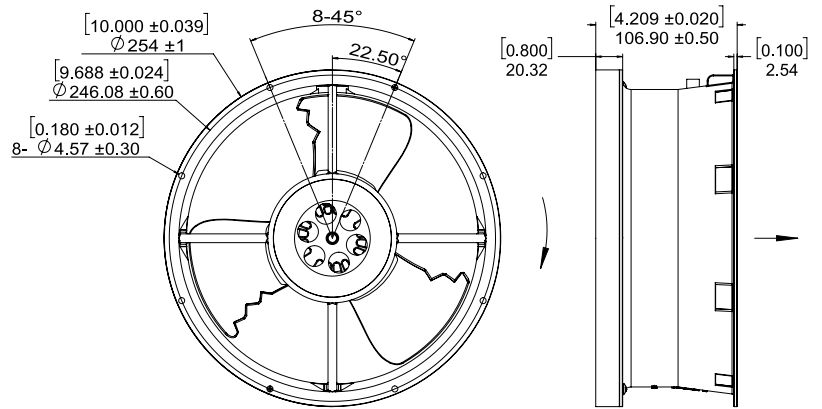

STANDARD FEATURES

- Size: 254.00 × 106.90 mm deep (10.00" × 4.21")
- Operating Temperature: -10°C to +70°C
- Storage Temperature: -40°C to +85°C
- Weight: 2.1 Kg (4.6 lbs)
- Dual Ball Bearings
- Impeller: Polycarbonate
- Venturi: Metal Alloy
- 12" Lead Wires or 2 Solder Terminals
- 50/60 Hz Operational

BENEFITS

- Outstanding CFM Performance in High Pressure Systems
- Dependability with an 12 Month Warranty
- Extend Bearing Life
- Designed with AC FPS option
- Available custom lead lengths
- This fan is designed for continuous duty life of 45,000 Hours at 60°C (L10)

STANDARD FEATURES

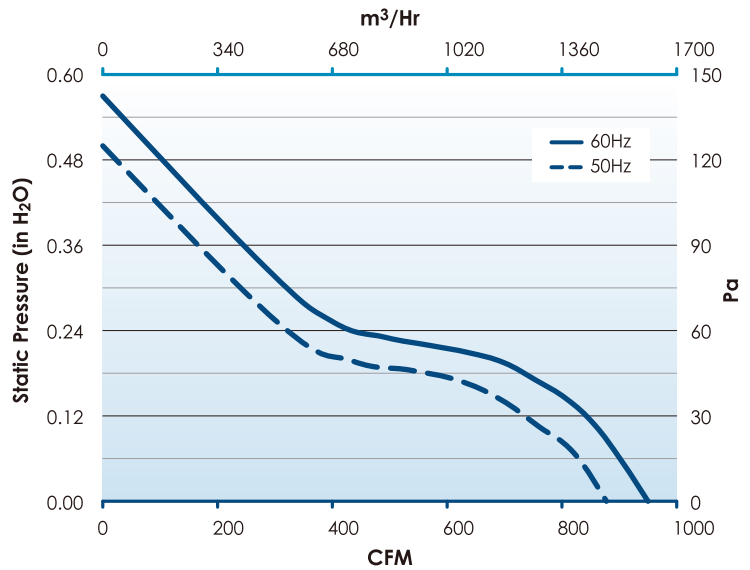

PARAMETER TABLE

Model Number	Part Number	Termination	Rated Voltage	Frequency	Rated Current	Rated Input Power	Speed	Rated Air Flow		Rated Air Pressure		Noise
			VAC	Hz	Amps	Watts	RPM	CFM	m ³ /Hr	inch-H ₂ O	Pascal	
CLE2L5	19039305A	Leadwires	115	50/60	1.11/1.35	120/150	2650/2800	878/950	1492/1615	0.50/0.57	125/142	62.1/63.3
CLE2T5	19039202A	Terminals	115	50/60	1.11/1.35	120/150	2650/2800	878/950	1492/1615	0.50/0.57	125/142	62.1/63.3
CLE3L5	19039306A	Leadwires	220/230	50/60	0.44/0.57	98/135	2650/2800	878/950	1492/1615	0.50/0.57	125/142	62.1/63.3
CLE3T5	19039203A	Terminals	220/230	50/60	0.44/0.57	98/135	2650/2800	878/950	1492/1615	0.50/0.57	125/142	62.1/63.3



GALAXY DC



127x38mm COTS FAN

MILITARY GRADE



Model Number GLD24B3EQ-E3

Part Number 042000

MECHANICAL DRAWING

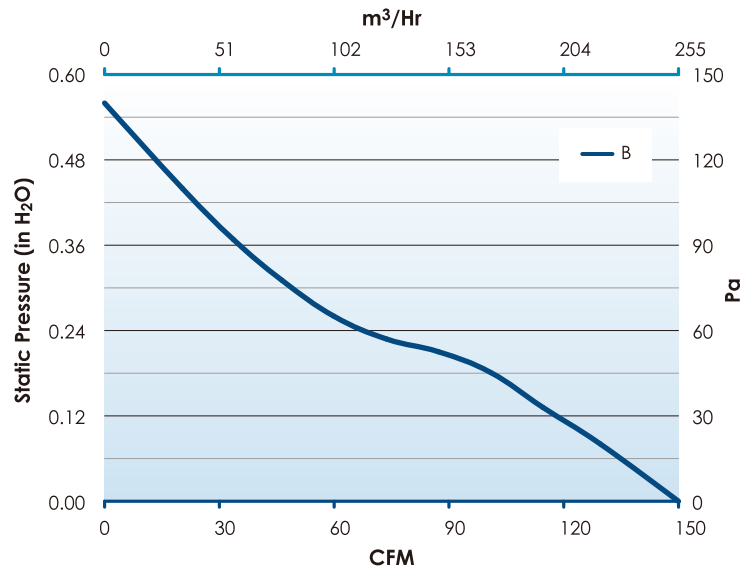

PERFORMANCE SPECS (at nominal voltage conditions)

Nominal Voltage	24 Volts DC	Rated Input Power	11 Watts	Speed	3300 RPM
Operating Voltage Range	16~32 VDC	Rated Airflow	150 CFM	Noise	53.6 dBA
Rated Current	0.45 Amps	Rated Air Pressure	0.56 In-H ₂ O	Weight	1.38 lbs

MECHANICAL DRAWING

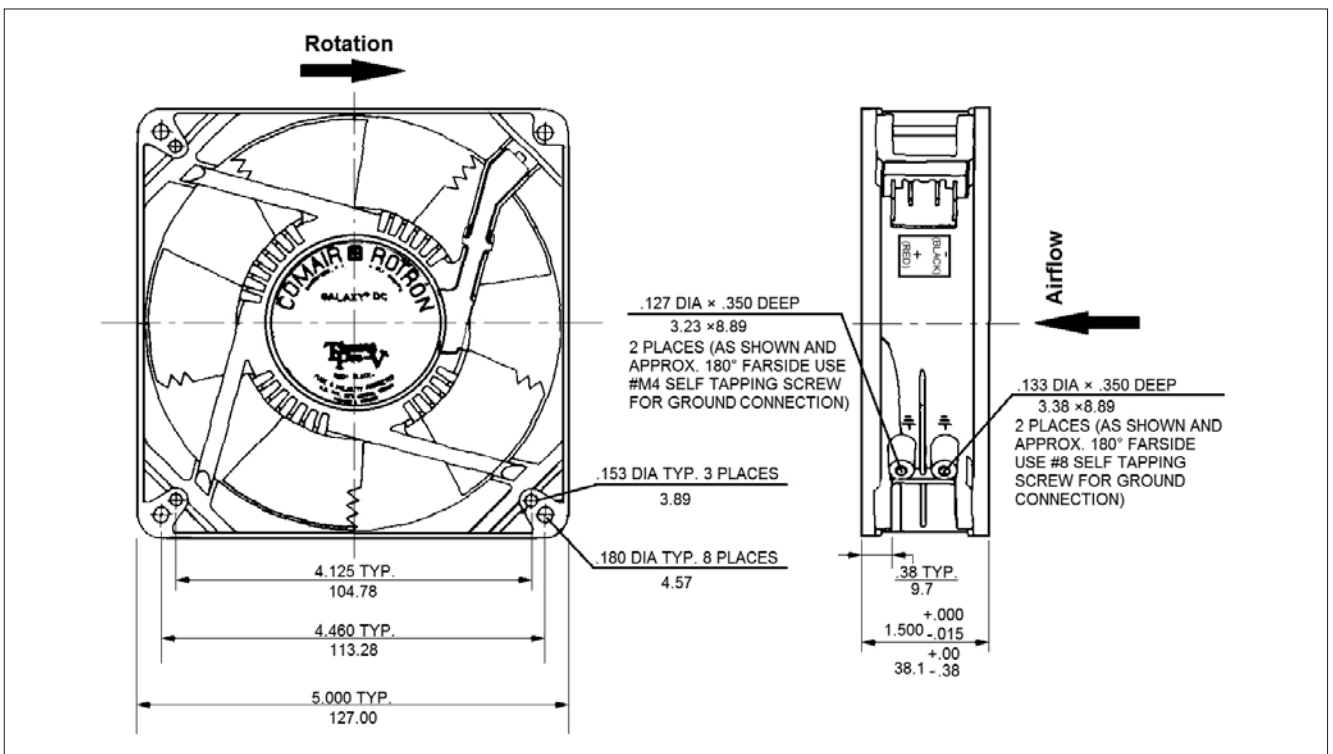

PATRIOT DC

172x51mm COTS FAN

MILITARY GRADE



MECHANICAL DRAWING

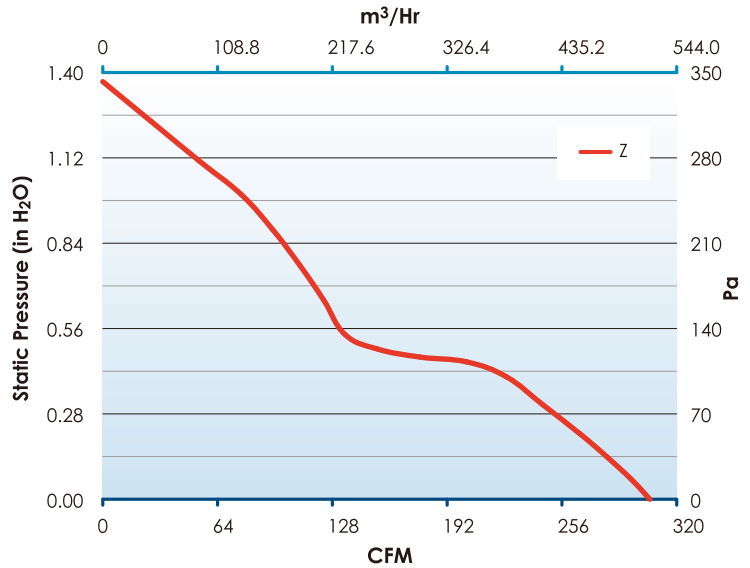

Model Number PQ4BZ3EQ-E3

Part Number 042011

PERFORMANCE SPECS (at nominal voltage conditions)

Nominal Voltage	48 Volts DC	Rated Input Power	32 Watts	Speed	4500 RPM
Operating Voltage Range	36~60 VDC	Rated Airflow	305 CFM	Noise	60.4 dBA
Rated Current	0.7 Amps	Rated Air Pressure	1.37 In-H ₂ O	Weight	1.84 lbs

MECHANICAL DRAWING

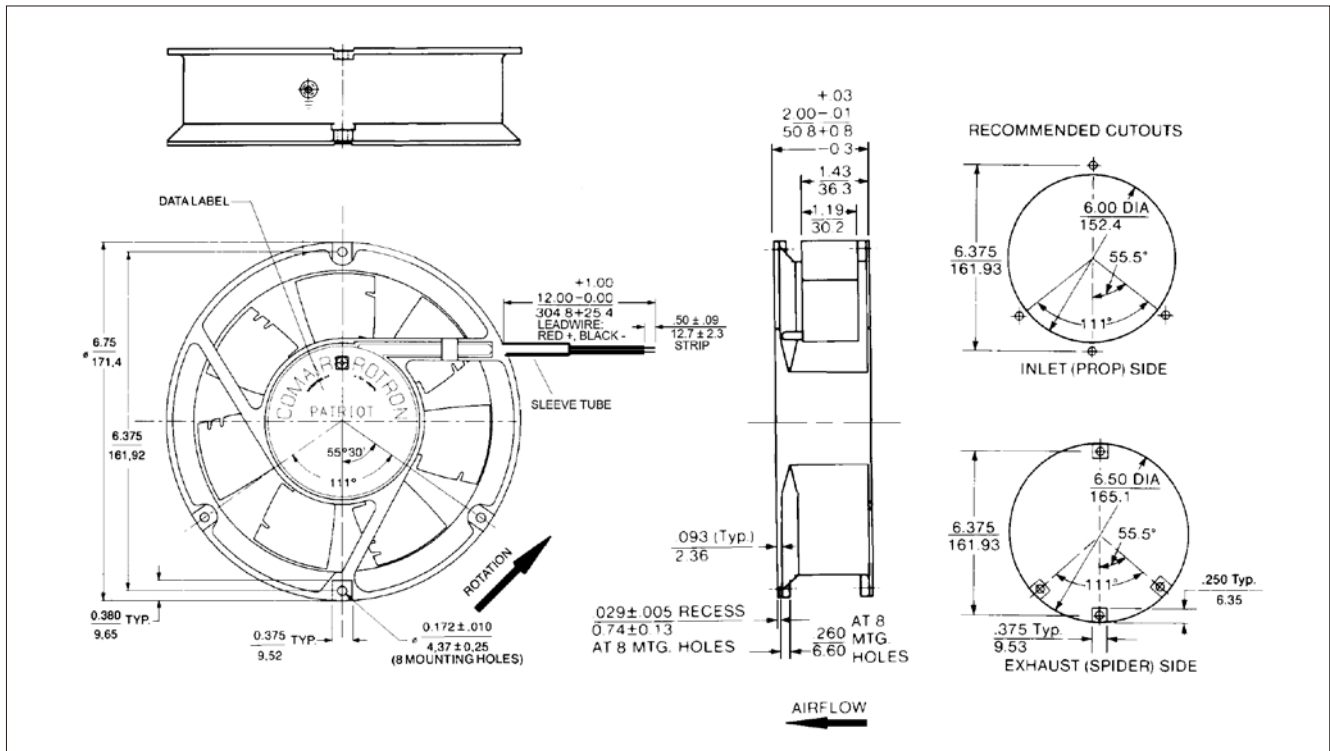

E3-Protection

E3-Protection Product for harsh Environment Announcement



Comair Rotron's Environmental Protection was developed to protect against harsh environments such as exposure to water, salt, dust, etc., and to improve shock and vibration requirements of our products. Our highest level of protection, Level 3 (E3), is a fully encapsulated motor and PC board, which is designed to meet many environmental ratings, such as Belcore's GR-487 Spec as well as various IP and NEMA ratings. The following DC products have been designed to allow for our E3 encapsulation:

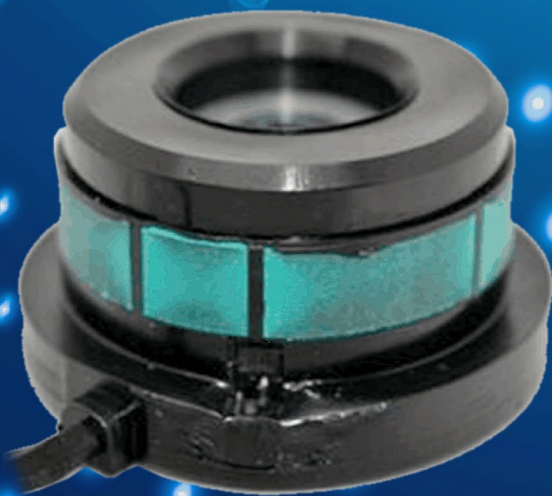

Family Name	Model Code
Whiffet DC	WT
Sprint DC	STD
Sprite DC	SDD
Whisper XL DC	WD
Muffin XP DC	MSD
Muffin XL DC	MDD
Galaxy DC	GLD
Major DC	JQD
Patriot DC	PQD
Diplomat DD4021	DD4021
Diplomat DD6921	DD6921
Diplomat DD6927	DD6927
Diplomat DDE8928	DDE8928
Diplomat DDE8939	DDE8939
Diplomat DDE1149	DDE1149

Nomenclature Guide

Model Number

JQD48B1C2X-E2

1 2 3 4 5 6 7 8

1 Product Name

DC FAN

ST=Sprite DC	SD=Sprite DC
WD=Whisper XL DC	MC=Muffin DC Ms=Muffin XP DC
MD=Muffin XL DC	MDD=Muffin XL DC Digital
GL=Galaxy DC	GLD=Galaxy DC Digital
JQ=Major DC	JQD=Major DC Digital
PQ=Patriot DC	PQD=Patriot DC Digital
MT=Maltese DC	MTD=Maltese DC Digital
TD=Tarzan DC	CD=Caravel DC

AC FAN

SU=Sprite AC	MX=Muffin XL AC
MR=Major AC	PT=Patriot AC
MA=Maltese AC	TNE=Tarzan AC
CLE=Caravel AC / Caravel XL AC	

MIXFLOW FAN

MFXE=Mixtus 6.8 DC MFSE=Mixtus 7.9 DC

DC MOTORIZED IMPELLER

DD4021=Diplomat DD4021	DD6921=Diplomat DD6921
DD6927=Diplomat DD6927	DD8928=Diplomat DD8928
DD8939=Diplomat DD8939	DDE1149=Diplomat DDE1149

DC BLOWER

WT=Whiffet DC BD=Biscuit DC SPD=Spinnaker DC

2 Nominal Voltage

DC

05=5 VDC 12=12 VDC
24=24 VDC 48=48 VDC

AC

2=115V,50/60Hz 3=230V,50/60Hz
77=220~240V/208~230V,50/60Hz

3 Major Electromechanical Variations

DC

M=5/8 SPEED B=FULL SPEED
K=HIGH SPEED Z=EXTRA-HIGH SPEED
U=ULTRA-HIGH SPEED

AC

B=STD, SPEED D=HALF SPEED

4 Termination

1=LEADWIRES 2=TERMINALS
6=HARNESS(CUSTOMERIZATION)

5 Outputs:Alarms/Fan Performance Sensor

A=TACHOMETER F=5V TTL
C=OPEN COLLECTOR

6 Inputs:Speed Control

1=THERMAL:PTC/NTC 2=PWM
5=VOLTAGE 7=ON/OFF

7 Non-Standard

X=MINOR ELECTROMECHANICAL VARIATIONS,
LEAD LENGTH, MOUNTING, ETC.,
NOT AFFECTING BASIC FAN PERFORMANC

8 Environmental Protection

E=ENVIRONMENTAL PROTECTION
(PER UL SECTION GENERAL)
E1 E2 E3

“Air moving solutions made simple”



Custom Engineered Solutions

Comair Rotron is an engineering based company which is able to design, develop, gain approval and manufacture integrated custom cooling solutions based on the customer's individual cooling specifications.

All solutions can incorporate internationally recognized standards including UL, CE.

A Comair Rotron turnkey solution can include a complete assembly comprising fans, controllers, blowers, impellers, PCB's, plastic moldings, sheet metal enclosures, wiring harnesses, RFI suppression, air filtering or whatever your thermal needs dictate.

Whether your application involves network servers, telecommunications equipment, automotive applications, electronic cabinets, computers, HVAC, medical, safety or laboratory equipment Comair Rotron's custom cooling solutions will solve your thermal requirements.

“Air moving solutions made simple”

Comair Rotron

Shanghai Comair Rotron Fan Co.,Ltd.

Bldg 15 No.506 Nanhuan Road Xinqiao Town,
Songjiang, District, Shanghai China 201612
Tel: +86-21-67693756 Fax: +86-21-67693135 Ext 808
Email: scao@comairrotron.com

Comair Rotron LLC

901 Waterfall Way Suite 701 Richardson, TX 75080, USA
Tel: 214-623-6333 Email: sales@comairrotron.com

www.ComairRotron.com

