

CATALOG 2023-2025

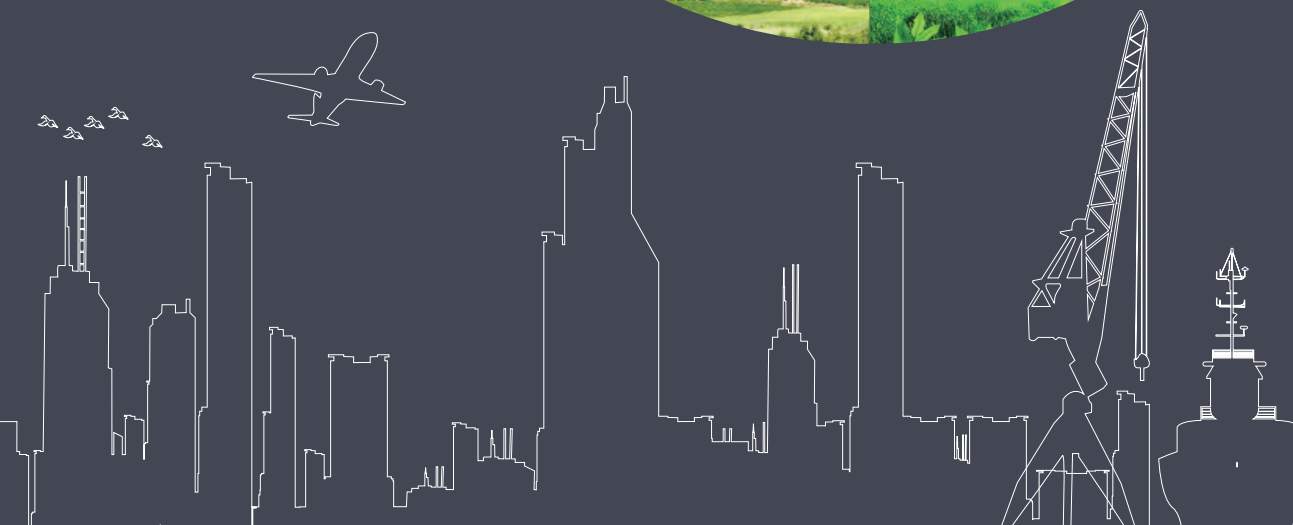

功率模块 产品手册

POWER MODULES



SILVERMICRO

南京银茂微电子制造有限公司

南京银茂微电子制造有限公司是一家以富有行业经验的留美博士团队为核心创建，以设计、研发和生产拥有自主知识产权的各类新型IGBT，MOSFET功率模块和第三代半导体SiC，GaN功率模块为核心的高新技术企业。公司成立于2007年11月，注册资金8000万人民币。公司产业园位于江苏南京溧水经济开发区内，占地120亩，建成了总计逾二万平方米的电子厂房、办公楼、研发楼及生活区。

节能、减排和充分利用绿色能源是我国可持续发展的关键。各种节能装置的小型化、智能化趋势越来越要求新的功率器件向高功率密度，低热损耗和高可靠性方向发展。南京银茂微电子具有研发和制造国产高可靠性新型电力电子模块的专业团队。至今已获得26项技术专利。建有获南京市科委认定的南京市电力电子功率器件工程技术研究中心。获得中国质量认证中心（CQC）ISO9001和ISO14001,SGS的IATF16949汽车品质双体系认证；国际ROHS，REACH和UL认证。公司严格执行全面质量管理之理念，配置了目前世界上最先进的工艺制造、产品测试和可靠性测试等设备，具备年产中小功率模块500万件以上和高压大功率模块10万件以上的生产能力。产品广泛应用于工业变频节能、逆变焊机、通讯电源、轨道交通、新能源汽车，医疗设备、民用航空及新能源等各个领域。

应用领域 | 工业变频、新能源、电源装备、混合电动汽车、公共交通等。

服务宗旨 | 本着“创新”+“革新”精神，为我们的客户打造高品质的核心器件！

奋斗目标 | 做世界功率器件市场知名的民族品牌！



NANJING SILVERMICRO ELECTRONICS

Nanjing SilverMicro Electronics focuses on design and manufacturing IGBT , MOSFET power modules as well as SiC, GaN power modules for industrial and other applications. SilverMicro was founded in 2007 in Nanjing, China. Our company occupies more than 20 acres and have constructed over twenty thousand square meters of manufacturing building, office building, R&D buildings and dorm buildings, including a 3000m2 cleanrooms.

We have established advanced power module manufacturing capability by adopting modern equipment on processing and characterizing power modules up to 3.3kV. We are certified to ISO9001 as well as ISO14001 since 2009, and IATF 16949 since 2016. Majority of our products are also UL certified. We are also capable of performing power module qualification testing such as AEC Q101 electrical and environmental life tests in house.

Innovation and improvement are our relentless pursuitment. We have developed more than fifteen package platforms and have been granted over 26 patents in China so far. Our products have been used for industrial inverters, equipments, UPS, power supplies and new energy applications. Customization is also our strong forte, and we have successfully developed a series of power modules for our customer’ s dedicated applications. We focus on quality and efficiency, and deliver values to our customers.



公司简介 01-02

About SilverMicro

模块命名 04

Module Nomenclature

产品快速查找 05-07

Quick Reference

IGBT功率模块 08-86

IGBT Power Modules

智能功率模块 87-88

Intelligent Power Modules

MOSFET功率模块 89-92

MOSFET Power Modules

汽车模块 93-109

Automotive Modules

SiC MOSFET模块 110-117

SiC MOSFET Modules

GaN 模块 118-119

GaN Modules

快恢二极管模块 120-123

Diode Modules

整流模块 124-131

Rectifier Modules

晶闸管模块 132-135

Thyristor(SCR) Modules

Power Module Nomenclature

G T 400 HF 120 T2V H

Module Type

G=IGBT Module
D=Diode Module
M=MOSFET Module
R=Rectifier Module

Die Characteristics

K=NPT,Standard IGBT
F=NPT,Fast IGBT
L=SPT+,Low Switching Losses IGBT
U=Trench,Ultra Fast IGBT
T=Trench,Low Switching Losses IGBT
TS=Trench,Low Switching Losses IGBT
TM=Trench,Low Switching Losses IGBT
N=NPT MOSFET
M=Trench MOSFET
D=Fast Recovery Diode
S=SCR
GN=GaN MOSFET
SC=SiC MOSFET

Rated Current

For example:400=400A, 50=50A

Circuit Configuration

SD= Single Switch(IGBT+FWD)
CU= Chopper(Diode on High Side)
CL= Chopper(Diode on Lower Side)
CH=Chopper(CU+CL)
CK=Common Cathode
HF= Half Bridge
HH= H Bridge
FF= Full Bridge
FB= Seven Pack
PI = Power Integrated
IP= Integrated Power
TL= Three Level(I Type)
TAR= Three Level(FRD on Collector, Emitter)
TT= Three Level(T Type)

Test Level

E= Pass the Electrical Performance Test
H= Pass the Important Reliability Test-Industrial Grade
S= Pass the Comprehensive Reliability Test-Automotive Grade

Package Type

T1*= 94mmx34mm, Copper
T2*= 106mmx62mm, Copper
T3=140mmx130mm, Copper
T4=140mmx190mm, Copper/AlSiC
T5=108mmx47mm, Copper
T6=122mmx62mm, Copper
T7=125mmx94mm, Copper
T8=120mmx80mm, Copper/AlSiC
T9= 150mmx62mm, Copper
A1= 67mmx40mm, Al2O3 Substrate
A2= 45mmx26mm, Al2O3 Substrate
A3= 58mmx40mm, Al2O3 Substrate
A4= 110mmx80mm,Copper
A5=94mmx45mm, Copper
A6=105.9mmx59.9mm, AlSiC
A7=64mmx40mm, Al2O3 Substrate
A7B=51mmx31mm, Al2O3 Substrate
A8=130mmx102mm, Copper
A9=93 mmx 21mm, Copper
B1=90mmx60mm, Copper
B2=66mmx31mm, Al2O3 Substrate
B3=63mmx34mm, Al2O3 Substrate
B4=89mmx55mm, Copper
B5=38mmx27mm, Copper
B6=123mmx103mm, Aluminum Substrate
B7=122mmx70mm, Copper
B8=213mmx97mm, Copper/AlSiC
B9=63mmx57mm, Al2O3 Substrate
C1=60mmx32mm, Copper
C2=72mmx42mm, Copper
C3=94mmx54mm, Copper
C4=94mmx50mm, Copper
C5=108mmx62mm, Copper
C6=84mmx34mm, Al2O3 Substrate
C7=82mmx37.4mm, Al2O3 Substrate
C8=152mmx92mm, Copper/AlSiC
C8N=152mmx72mm, Copper/AlSiC
P2=92mmx50mm,Copper
P3=247mmx86mm,Copper
P4=169mmx86mm,Copper

Rated Voltage/10

For example: 60=600V, 120=1200V

T1*=T1,T1V,T1W

T2*=T2,T2V,T2N,T2L,T2Z,T2S



TYPE	TOPOLOGY	VOLTAGE(V)	CURRENT(A)	PACKAGE	PAGE	
IGBT 功率模块 IGBT Power Modules	Power Integrated Module (PIM IGBT模块)					
	PI(Full Bridge+Chopper+Rectifier)	600	10,20,30,35,50,75,100		B2,B3,B9,	08-15
		650	10,20,35,50,75,100		C6,C7,	
		1200	10,15,25,35,40,50,75,100,150		T5,T6	
	Full Bridge (全桥IGBT模块)					
	FF(Full Bridge)	650	35,50,75,100,150,200,300,400		A1,A6,A8,B3,B9,	16-22
		1200	10,15,25,35,50,75,100,150,200,300		C6,C7,T5,T6	
	Seven Pack (7单元IGBT模块)					
	FB(Seven Pack)	600	10,20,35,50,75		A1,B3,C7	23-24
		1200	10,15,25,35,40,50			
	H-Bridge (H 桥IGBT模块)					
	HH(H-Bridge)	650	35,50,75,100,150,200		A1,A7B,B3, C7,T2,T5,T6	25-30
		1200	35,40,50,75,100,150,200			
	Half Bridge (半桥IGBT模块)					
	HF(Half Bridge)	650	75,100,150,200,300,400,450,600		A4,A5,B1,P3,P4	31-41
		1200	40,50,75,100,150,200,225,300,400,450,600,1200		T1,T1V,T1W,T2V, T2N,T2L,T8,T9	
		1700	100,150,200,300,450,600,1000			
	Single Switch(单管IGBT模块)					
	SD(IGBT+FWD)	650	200,300,400,600,800,900		A2,B5,T2Z,T3,T4	42-46
		1200	50,75,100,150,200,300,400,600,800,900,2400,3600			
		1700	100,200,300,600,900,1200,2400,3600			
Chopper (斩波IGBT模块)						
CU(Chopper,Diode on High Side)	650	225,300,450,600		A5,B5,T1, T1V,T2V,T2N,T9	46-52	
	1200	50,75,100,150,200,225,300,400,450,600				
	1700	100,150,200,300				
CL(Chopper,Diode on Lower Side)	650	225,300,450,600				
	1200	50,75,100,150,200,225,300,400,450,600				
	1700	100,150,200,300				
DF(Three Groups Chopper,Diode on Lower Side)	650	200,300,400		A8		
	1200	100,150,200				
FD(Three Groups Chopper,Diode on High Side)	650	200,300,400				
	1200	100,150,200				
CH(CU+CL)	650	50,75		B2,T2,T9		
	1200	75,100,150,200,225,300,450,600				
CZ(CU+CL)	650	75,100,150,200		T5,T6		
	1200	50,75,100,150,200				

TYPE	TOPOLOGY	VOLTAGE(V)	CURRENT(A)	PACKAGE	PAGE
IGBT 功率模块	Three level (三电平IGBT模块)				
	TL(Three level,I Type)	650	50,75,100,150,200,300,400,500,600	A8,B2,B3,B9,	53-58
		1200	50,100,150,200,300	T2S,T7	
	TAR(Three level,FRD on Collector, Emitter)	650	150,200,300,400	T2S	
	IGBT Power Modules	TT(Three level,T Type)	650	50,75	
MAR(Three level,Emitter Controlled HE diode)		1200	200,300	T9	
MCR(Three level,Emitter Controlled HE diode)	1200	200,300			
IGBT功率模块外形图 / IGBT Power Module Package Outline					59-86
智能功率 模块	Intelligent Power Modules (IPM智能功率模块)				
Intelligent Power Modules	IPM	600	30,50	A7	87
		1200	5,10,15,20,30		
智能功率模块外形图 / Intelligent Power Module Package Outline					88
MOSFET 功率模块	Half Bridge (半桥MOSFET模块)				
MOSFET Power Modules	HF(Half Bridge)	100	500,700,900,1000,1200,1400	B1,T2N	89-91
		150	340,500,680,850		
		200	450,550,650		
MOSFET功率模块外形图 / MOSFET Power Module Package Outline					92
汽车模块 Automotive Modules	Full Bridge (全桥IGBT模块)				
	FF(Full Bridge)	650	200,300,400,550	A8,B3,B8,B9, C8,C8N	93-97
		750	200,300,400,600,800		
		1200	25,35,40,50,75,100,150,200,300,400,600		
	Half Bridge (半桥IGBT模块)				
	HF(Half Bridge)	650	300,450,600	T9	98
		1200	225,300,450,600		
		1700	300,450,600		
	Half Bridge (半桥MOSFET模块)				
	HF(Half Bridge)	100	500,700,900,1000,1200,1400	B1,T2L	99-100
		150	340,500,680,850		
		200	450,550,650		
Full Bridge (全桥SiC MOSFET模块)					
FF(Full Bridge)	1200	200,300,400,510,620,720	C8,C8N	101	
Half Bridge (半桥SiC MOSFET模块)					
HF(Half Bridge)	1200	120,160,240,300	T2L	102	
	1700	300			
汽车模块外形图 / IGBT Power Module Package Outline					103-109

TYPE	TOPOLOGY	VOLTAGE(V)	CURRENT(A)	PACKAGE	PAGE	
SiC MOSFET 模块	Half Bridge (半桥SiC MOSFET模块)					
	HF(Half Bridge)	1200	120,150,160,240,300	B9,T2N,T2L	110-111	
		1700	300			
	Full Bridge (全桥SiC MOSFET模块)					
	FF(Full Bridge)	1200	20,50	C7,T5	111-112	
		1700	50			
	SiC MOSFET Modules	Single Phase Rectifier Bridge (单相整流SiC MOSFET模块)				
		FH(Single Phase Rectifier Bridge)	600	30	B3	112
			1200	30		
		Three level (三电平SiC MOSFET模块)				
TL(Three level,I Type)	650	150,200,300,400	A8,B9	113		
SiC MOSFET 模块外形图 / SiC MOSFET Module Package Outline					114-117	
GaN 模块 GaN Modules	Full Bridge (全桥GaN模块)					
	FF(Full Bridge)	650	300	C8B	118	
GaN 模块外形图 / GaN Module Package Outline					119	
快恢 二极管 模块 Diode Modules	Half Bridge (半桥二极管模块)					
	HF(Half Bridge)	1200	100,150,200	A9,T1W	120	
		1700	100,150			
	Single Diode (单管二极管模块)					
	SD(Diode)	1200	100,150,200,300,400	A9,T1W	121-122	
		1700	100,150,200,300			
Common Cathode (共阴极二极管模块)						
CK(Common Cathode)	1200	100,150,200	A9	122		
快恢二极管模块外形图 / Diode Module Package Outline					123	
整流模块 Rectifier Modules	Half Bridge Rectifier Diode Modules (半桥整流二极管模块)					
	HF(Half Bridge)	1800	70,100,120,165,190,230,300	A9,T1W	124	
	Common Cathode Rectifier Diode Modules (共阴极整流二极管模块)					
	CK(Common Cathode)	1800	70,100,120,165,200,230,300	A9,T1W	124-125	
	Three Phase Rectifier Bridge (三相整流模块)					
	FF(Full Bridge)	1800	30,50,52,75,100,130,160,200,250	C1,C2,C3	125-126	
	Three Phase Rectifier Bridge+Thyristor (三相整流+SCR模块)					
FFS(Full Bridge+SCR)	1800	100,150,200	C4,C5	126-127		
整流模块外形图 / Rectifier Module Package Outline					128-131	
晶闸管模块 Thyristor(SCR) Modules	Half Bridge (半桥SCR模块)					
	HF(Half Bridge)	1800	60,90,110,130,160,320	A9,T1W,P2	132-133	
晶闸管模块外形图 / Thyristor(SCR) Module Package Outline					134-135	

IGBT功率模块

IGBT Power Modules

Power Integrated Module (PIM IGBT模块)

B2

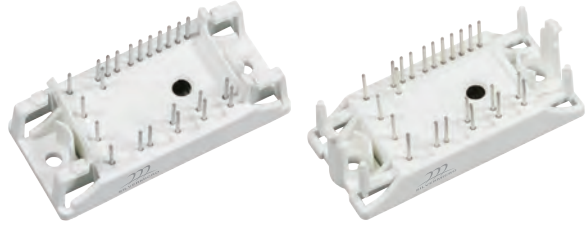
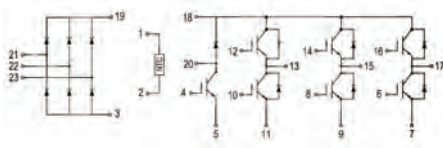

$V_{CES}=600V$

Part Number	Voltage(V)	Current(A)	Technology	Package Outline	Comments
标准型K系列-Standard K Series					
GK10PI60B2H	600	10	NPT	Page64 B2-PI	2-clip
GK10PI60B2FH	600	10	NPT	Page65 B2-PI(F)	4-clip
GK20PI60B2H	600	20	NPT	Page64 B2-PI	2-clip
GK20PI60B2FH	600	20	NPT	Page65 B2-PI(F)	4-clip

$V_{CES}=1200V$

Part Number	Voltage(V)	Current(A)	Technology	Package Outline	Comments
沟槽型T系列-Trench T Series					
GT10PI120B2H	1200	10	Trench FS	Page64 B2-PI	2-clip
GT10PI120B2FH	1200	10	Trench FS	Page65 B2-PI(F)	4-clip
GT15PI120B2H	1200	15	Trench FS	Page64 B2-PI	2-clip
GT15PI120B2FH	1200	15	Trench FS	Page65 B2-PI(F)	4-clip
沟槽型T系列-Trench T Series					
GTS10PI120B2H	1200	10	Trench FS	Page64 B2-PI	2-clip
GTS10PI120B2FH	1200	10	Trench FS	Page65 B2-PI(F)	4-clip
GTS15PI120B2H	1200	15	Trench FS	Page64 B2-PI	2-clip
GTS15PI120B2FH	1200	15	Trench FS	Page65 B2-PI(F)	4-clip

Power Integrated Module (PIM IGBT模块)

B3

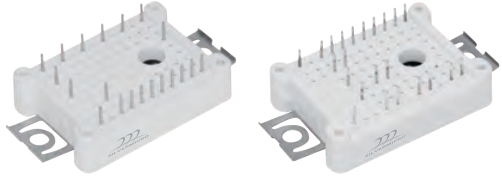
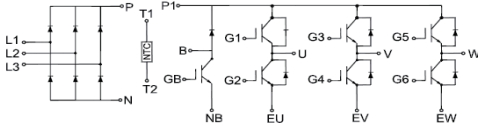

$V_{CES}=600V$

Part Number	Voltage(V)	Current(A)	Technology	Package Outline	Comments
标准型K系列-Standard K Series					
GK10PI60B3H	600	10	NPT	Page68 B3-PI	solder pins/pressfit pins
GK20PI60B3H	600	20	NPT	Page68 B3-PI	solder pins/pressfit pins

$V_{CES}=650V$

Part Number	Voltage(V)	Current(A)	Technology	Package Outline	Comments
沟槽型T系列-Trench T Series					
GT10PI65B3H	650	10	Trench FS	Page68 B3-PI	solder pins/pressfit pins
GT20PI65B3H	650	20	Trench FS	Page68 B3-PI	solder pins/pressfit pins
GT35PI65B3H	650	35	Trench FS	Page68 B3-PI	solder pins/pressfit pins

$V_{CES}=1200V$

Part Number	Voltage(V)	Current(A)	Technology	Package Outline	Comments
沟槽型T系列-Trench T Series					
GT10PI120B3H	1200	10	Trench FS	Page68 B3-PI	solder pins/pressfit pins
GT15PI120B3H	1200	15	Trench FS	Page68 B3-PI	solder pins/pressfit pins
沟槽型T系列-Trench T Series					
GTS10PI120B3H	1200	10	Trench FS	Page68 B3-PI	solder pins/pressfit pins
GTS15PI120B3H	1200	15	Trench FS	Page68 B3-PI	solder pins/pressfit pins

Power Integrated Module (PIM IGBT模块)

B9

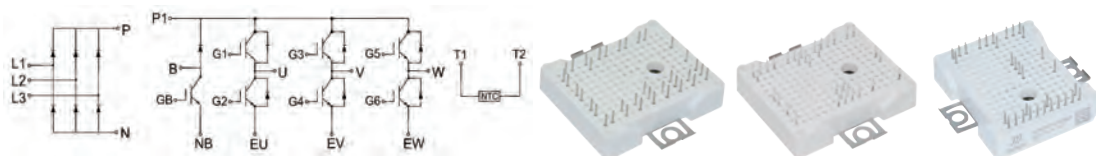

$V_{CES}=600V$

Part Number	Voltage(V)	Current(A)	Technology	Package Outline	Comments
标准型K系列-Standard K Series					
GK30PI60B9H	600	30	NPT	Page70 B9-PI	solder pins/pressfit pins
GK50PI60B9H	600	50	NPT	Page70 B9-PI	solder pins/pressfit pins

$V_{CES}=650V$

Part Number	Voltage(V)	Current(A)	Technology	Package Outline	Comments
沟槽型T系列-Trench T Series					
GT35PI65B9H	650	35	Trench FS	Page70 B9-PI	solder pins/pressfit pins
GT50PI65B9H	650	50	Trench FS	Page70 B9-PI	solder pins/pressfit pins

$V_{CES}=1200V$

Part Number	Voltage(V)	Current(A)	Technology	Package Outline	Comments
沟槽型T系列-Trench T Series					
GT15PI120B9H	1200	15	Trench FS	Page70 B9-PI	solder pins/pressfit pins
GT25PI120B9H	1200	25	Trench FS	Page70 B9-PI	solder pins/pressfit pins
GT35PI120B9H	1200	35	Trench FS	Page70 B9-PI	solder pins/pressfit pins
沟槽型T系列-Trench T Series					
GTS15PI120B9H	1200	15	Trench FS	Page70 B9-PI	solder pins/pressfit pins
GTS25PI120B9H	1200	25	Trench FS	Page70 B9-PI	solder pins/pressfit pins
GTS40PI120B9H	1200	40	Trench FS	Page70 B9-PI	solder pins/pressfit pins

Power Integrated Module (PIM IGBT模块)

C6

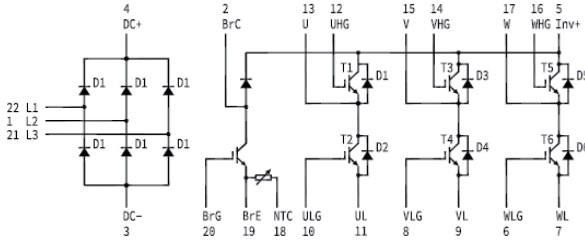

$V_{CES}=600V$

Part Number	Voltage(V)	Current(A)	Technology	Package Outline	Comments
标准型K系列-Standard K Series					
GK10PI60C6H	600	10	NPT	Page71 C6-PI	
GK20PI60C6H	600	20	NPT	Page71 C6-PI	
GK30PI60C6H	600	30	NPT	Page71 C6-PI	

$V_{CES}=650V$

Part Number	Voltage(V)	Current(A)	Technology	Package Outline	Comments
沟槽型T系列-Trench T Series					
GT10PI65C6H	650	10	Trench FS	Page71 C6-PI	
GT20PI65C6H	650	20	Trench FS	Page71 C6-PI	
GT35PI65C6H	650	35	Trench FS	Page71 C6-PI	

$V_{CES}=1200V$

Part Number	Voltage(V)	Current(A)	Technology	Package Outline	Comments
沟槽型T系列-Trench T Series					
GT10PI120C6H	1200	10	Trench FS	Page71 C6-PI	
GT15PI120C6H	1200	15	Trench FS	Page71 C6-PI	
GT25PI120C6H	1200	25	Trench FS	Page71 C6-PI	
沟槽型T系列-Trench T Series					
GTS10PI120C6H	1200	10	Trench FS	Page71 C6-PI	
GTS15PI120C6H	1200	15	Trench FS	Page71 C6-PI	
GTS25PI120C6H	1200	25	Trench FS	Page71 C6-PI	

Power Integrated Module (PIM IGBT模块)

C7

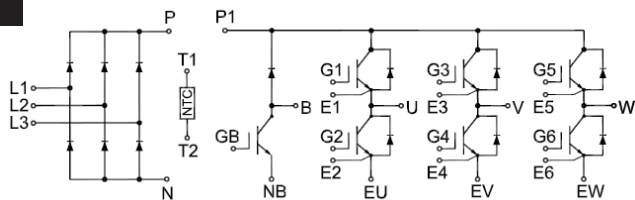

$V_{CES}=600V$

Part Number	Voltage(V)	Current(A)	Technology	Package Outline	Comments
标准型K系列-Standard K Series					
GK35PI60C7H	600	35	NPT	Page73 C7-PI	
GK50PI60C7H	600	50	NPT	Page73 C7-PI	

$V_{CES}=650V$

Part Number	Voltage(V)	Current(A)	Technology	Package Outline	Comments
沟槽型T系列-Trench T Series					
GT35PI65C7H	650	35	Trench FS	Page73 C7-PI	
GT50PI65C7H	650	50	Trench FS	Page73 C7-PI	

$V_{CES}=1200V$

Part Number	Voltage(V)	Current(A)	Technology	Package Outline	Comments
沟槽型T系列-Trench T Series					
GT15PI120C7H	1200	15	Trench FS	Page73 C7-PI	
GT25PI120C7H	1200	25	Trench FS	Page73 C7-PI	
GT40PI120C7H	1200	40	Trench FS	Page73 C7-PI	
沟槽型T系列-Trench T Series					
GTS15PI120C7H	1200	15	Trench FS	Page73 C7-PI	
GTS25PI120C7H	1200	25	Trench FS	Page73 C7-PI	
GTS40PI120C7H	1200	40	Trench FS	Page73 C7-PI	

Power Integrated Module (PIM IGBT模块)

T5

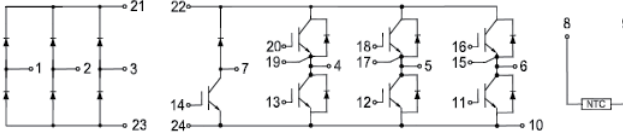

$V_{CES}=600V$

Part Number	Voltage(V)	Current(A)	Technology	Package Outline	Comments
标准型K系列-Standard K Series					
GK10PI60T5H	600	10	NPT	Page83 T5-PI	
GK20PI60T5H	600	20	NPT	Page83 T5-PI	
GK35PI60T5H	600	35	NPT	Page83 T5-PI	
GK50PI60T5H	600	50	NPT	Page83 T5-PI	
标准型K系列-Standard K Series					
GK10PI60T5H-T4	600	10	NPT	Page82 T5-PI-T4	
GK20PI60T5H-T4	600	20	NPT	Page82 T5-PI-T4	
GK35PI60T5H-T4	600	35	NPT	Page82 T5-PI-T4	
GK50PI60T5H-T4	600	50	NPT	Page82 T5-PI-T4	

$V_{CES}=650V$

Part Number	Voltage(V)	Current(A)	Technology	Package Outline	Comments
沟槽型T系列-Trench T Series					
GT50PI65T5H-M	650	50	Trench FS	Page83 T5-PI	
GT75PI65T5H-M	650	75	Trench FS	Page83 T5-PI	

Power Integrated Module (PIM IGBT模块)

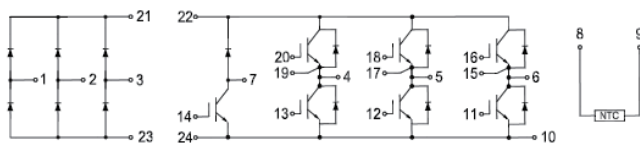
T5

$V_{CES} = 1200V$

Part Number	Voltage(V)	Current(A)	Technology	Package Outline	Comments
沟槽型T系列-Trench T Series					
GT10PI120T5H	1200	10	Trench FS	Page83 T5-PI	
GT15PI120T5H	1200	15	Trench FS	Page83 T5-PI	
GT25PI120T5H	1200	25	Trench FS	Page83 T5-PI	
GT40PI120T5H	1200	40	Trench FS	Page83 T5-PI	
沟槽型T系列-Trench T Series					
GT50PI120T5H-M	1200	50	Trench FS	Page83 T5-PI	
沟槽型T系列-Trench T Series					
GTS10PI120T5H	1200	10	Trench FS	Page83 T5-PI	
GTS15PI120T5H	1200	15	Trench FS	Page83 T5-PI	
GTS25PI120T5H	1200	25	Trench FS	Page83 T5-PI	
GTS40PI120T5H	1200	40	Trench FS	Page83 T5-PI	
沟槽型T系列-Trench T Series					
GT10PI120T5H-T4	1200	10	Trench FS	Page82 T5-PI-T4	
GT15PI120T5H-T4	1200	15	Trench FS	Page82 T5-PI-T4	
GT25PI120T5H-T4	1200	25	Trench FS	Page82 T5-PI-T4	
GT40PI120T5H-T4	1200	40	Trench FS	Page82 T5-PI-T4	
沟槽型T系列-Trench T Series					
GT50PI120T5H-T4M	1200	50	Trench FS	Page82 T5-PI-T4	
沟槽型T系列-Trench T Series					
GTS10PI120T5H-T4	1200	10	Trench FS	Page82 T5-PI-T4	
GTS15PI120T5H-T4	1200	15	Trench FS	Page82 T5-PI-T4	
GTS25PI120T5H-T4	1200	25	Trench FS	Page82 T5-PI-T4	
GTS40PI120T5H-T4	1200	40	Trench FS	Page82 T5-PI-T4	

Power Integrated Module (PIM IGBT模块)

T6

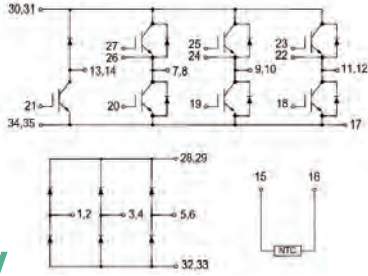

$V_{CES}=600V$

Part Number	Voltage(V)	Current(A)	Technology	Package Outline	Comments
标准型K系列-Standard K Series					
GK50PI60T6H	600	50	NPT	Page85 T6-PI	
GK75PI60T6H	600	75	NPT	Page85 T6-PI	
GK100PI60T6H	600	100	NPT	Page85 T6-PI	
标准型K系列-Standard K Series					
GK50PI60T6H-T4	600	50	NPT	Page85 T6-PI-T4	
GK75PI60T6H-T4	600	75	NPT	Page85 T6-PI-T4	
GK100PI60T6H-T4	600	100	NPT	Page85 T6-PI-T4	

$V_{CES}=650V$

Part Number	Voltage(V)	Current(A)	Technology	Package Outline	Comments
沟槽型T系列-Trench T Series					
GT75PI65T6H	650	75	Trench FS	Page85 T6-PI	
GT100PI65T6H	650	100	Trench FS	Page85 T6-PI	

$V_{CES}=1200V$

Part Number	Voltage(V)	Current(A)	Technology	Package Outline	Comments
沟槽型T系列-Trench T Series					
GT50PI120T6H-M	1200	50	Trench FS	Page85 T6-PI	
GT75PI120T6H-M	1200	75	Trench FS	Page85 T6-PI	
GT100PI120T6H-M	1200	100	Trench FS	Page85 T6-PI	
沟槽型T系列-Trench T Series					
GT50PI120T6H-T4M	1200	50	Trench FS	Page85 T6-PI-T4	
GT75PI120T6H-T4M	1200	75	Trench FS	Page85 T6-PI-T4	
GT100PI120T6H-T4M	1200	100	Trench FS	Page85 T6-PI-T4	
GT150PI120T6H-T4M	1200	150	Trench FS	Page85 T6-PI-T4	

Full Bridge (全桥IGBT模块)

A1

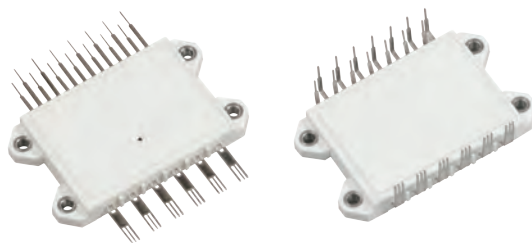
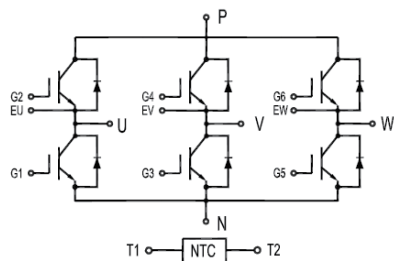

$V_{CES}=650V$

Part Number	Voltage(V)	Current(A)	Technology	Package Outline	Comments
沟槽型T系列-Trench T Series					
GT35FF65A1H	650	35	Trench FS	Page59 A1-FF	
GT50FF65A1H	650	50	Trench FS	Page59 A1-FF	
GT75FF65A1H	650	75	Trench FS	Page59 A1-FF	

$V_{CES}=1200V$

Part Number	Voltage(V)	Current(A)	Technology	Package Outline	Comments
沟槽型T系列-Trench T Series					
GT10FF120A1H	1200	10	Trench FS	Page59 A1-FF	
GT15FF120A1H	1200	15	Trench FS	Page59 A1-FF	
GT25FF120A1H	1200	25	Trench FS	Page59 A1-FF	
GT35FF120A1H	1200	35	Trench FS	Page59 A1-FF	
GT50FF120A1H	1200	50	Trench FS	Page59 A1-FF	
沟槽型T系列-Trench T Series					
GTS10FF120A1H	1200	10	Trench FS	Page59 A1-FF	
GTS15FF120A1H	1200	15	Trench FS	Page59 A1-FF	
GTS25FF120A1H	1200	25	Trench FS	Page59 A1-FF	
GTS40FF120A1H	1200	40	Trench FS	Page59 A1-FF	

Full Bridge (全桥IGBT模块)

A6

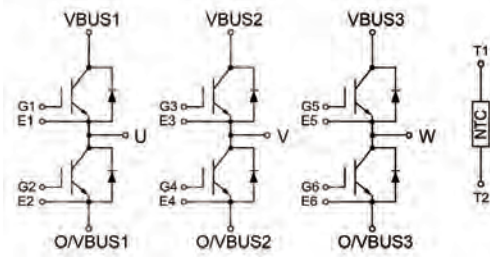

$V_{CES}=1200V$

Part Number	Voltage(V)	Current(A)	Technology	Package Outline	Comments
沟槽型T系列-Trench T Series					
GT50FF120A6H-M	1200	50	Trench FS	Page62 A6	
GT75FF120A6H-M	1200	75	Trench FS	Page62 A6	
GT100FF120A6H-M	1200	100	Trench FS	Page62 A6	

A8

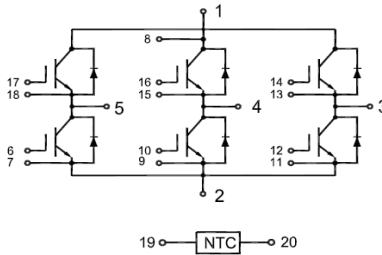

$V_{CES}=650V$

Part Number	Voltage(V)	Current(A)	Technology	Package Outline	Comments
沟槽型T系列-Trench T Series					
GT200FF65A8H	650	200	Trench FS	Page63 A8	
GT300FF65A8H	650	300	Trench FS	Page63 A8	
GT400FF65A8H	650	400	Trench FS	Page63 A8	

Full Bridge (全桥IGBT模块)

A8

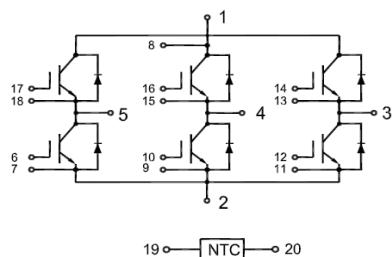

$V_{CES}=1200V$

Part Number	Voltage(V)	Current(A)	Technology	Package Outline	Comments
沟槽型T系列-Trench T Series					
GT100FF120A8H	1200	100	Trench FS	Page63 A8	
GT150FF120A8H	1200	150	Trench FS	Page63 A8	
GT200FF120A8H	1200	200	Trench FS	Page63 A8	
GT300FF120A8H	1200	300	Trench FS	Page63 A8	

B3

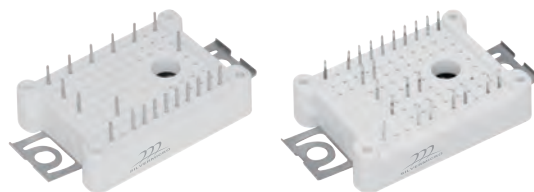
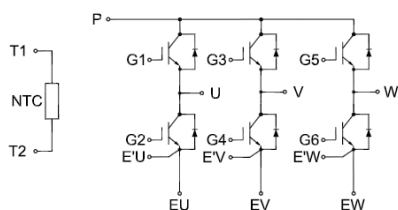

$V_{CES}=1200V$

Part Number	Voltage(V)	Current(A)	Technology	Package Outline	Comments
沟槽型T系列-Trench T Series					
GT25FF120B3H	1200	25	Trench FS	Page67 B3-FF	solder pins/pressfit pins
GT35FF120B3H	1200	35	Trench FS	Page67 B3-FF	solder pins/pressfit pins
沟槽型T系列-Trench T Series					
GTS25FF120B3H	1200	25	Trench FS	Page67 B3-FF	solder pins/pressfit pins
GTS40FF120B3H	1200	40	Trench FS	Page67 B3-FF	solder pins/pressfit pins

Full Bridge (全桥IGBT模块)

B9

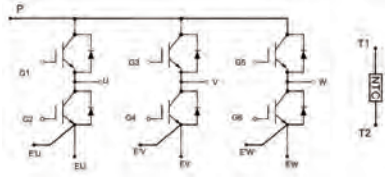

$V_{CES} = 1200V$

Part Number	Voltage(V)	Current(A)	Technology	Package Outline	Comments
沟槽型T系列-Trench T Series					
GT50FF120B9H	1200	50	Trench FS	Page69 B9-FF	solder pins/pressfit pins
GT75FF120B9H	1200	75	Trench FS	Page69 B9-FF	solder pins/pressfit pins

C6

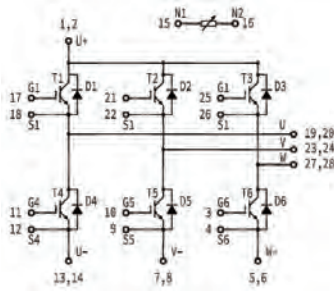

$V_{CES} = 1200V$

Part Number	Voltage(V)	Current(A)	Technology	Package Outline	Comments
沟槽型T系列-Trench T Series					
GT10FF120C6H	1200	10	Trench FS	Page71 C6-FF	
GT15FF120C6H	1200	15	Trench FS	Page71 C6-FF	
GT25FF120C6H	1200	25	Trench FS	Page71 C6-FF	
GT35FF120C6H	1200	35	Trench FS	Page71 C6-FF	
GT50FF120C6H	1200	50	Trench FS	Page71 C6-FF	
沟槽型T系列-Trench T Series					
GTS10FF120C6H	1200	10	Trench FS	Page71 C6-FF	
GTS15FF120C6H	1200	15	Trench FS	Page71 C6-FF	
GTS25FF120C6H	1200	25	Trench FS	Page71 C6-FF	
GTS40FF120C6H	1200	40	Trench FS	Page71 C6-FF	

Full Bridge (全桥IGBT模块)

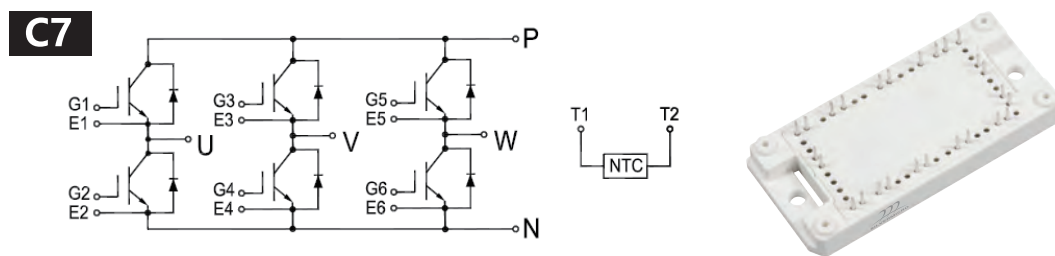

$V_{CES}=650V$

Part Number	Voltage(V)	Current(A)	Technology	Package Outline	Comments
沟槽型T系列-Trench T Series					
GT75FF65C7H	650	75	Trench FS	Page72 C7-FF	
GT100FF65C7H	650	100	Trench FS	Page72 C7-FF	

$V_{CES}=1200V$

Part Number	Voltage(V)	Current(A)	Technology	Package Outline	Comments
沟槽型T系列-Trench T Series					
GT40FF120C7H	1200	40	Trench FS	Page72 C7-FF	
GT50FF120C7H	1200	50	Trench FS	Page72 C7-FF	
GT75FF120C7H	1200	75	Trench FS	Page72 C7-FF	

Full Bridge (全桥IGBT模块)

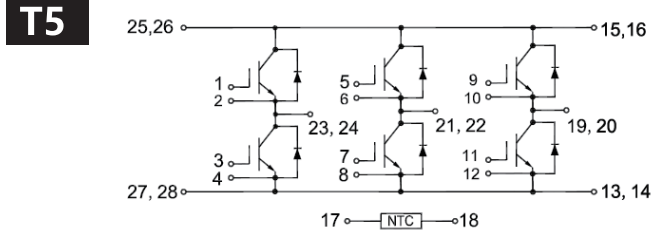

$V_{CES}=650V$

Part Number	Voltage(V)	Current(A)	Technology	Package Outline	Comments
沟槽型T系列-Trench T Series					
GT100FF65T5H	650	100	Trench FS	Page81 T5-FF	

$V_{CES}=1200V$

Part Number	Voltage(V)	Current(A)	Technology	Package Outline	Comments
沟槽型T系列-Trench T Series					
GT25FF120T5H	1200	25	Trench FS	Page81 T5-FF	
GT40FF120T5H	1200	40	Trench FS	Page81 T5-FF	
GT50FF120T5H	1200	50	Trench FS	Page81 T5-FF	
GT75FF120T5H	1200	75	Trench FS	Page81 T5-FF	
沟槽型T系列-Trench T Series					
GTS25FF120T5H	1200	25	Trench FS	Page81 T5-FF	
GTS40FF120T5H	1200	40	Trench FS	Page81 T5-FF	

Full Bridge (全桥IGBT模块)

T6

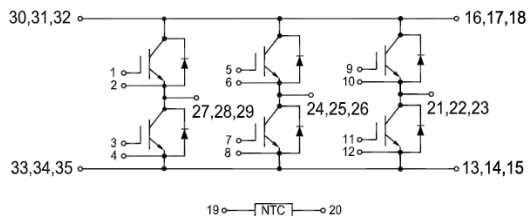

$V_{CES}=650V$

Part Number	Voltage(V)	Current(A)	Technology	Package Outline	Comments
沟槽型T系列-Trench T Series					
GT75FF65T6H	650	75	Trench FS	Page84 T6-FF	
GT100FF65T6H	650	100	Trench FS	Page84 T6-FF	
GT150FF65T6H	650	150	Trench FS	Page84 T6-FF	
GT200FF65T6H	650	200	Trench FS	Page84 T6-FF	

$V_{CES}=1200V$

Part Number	Voltage(V)	Current(A)	Technology	Package Outline	Comments
沟槽型T系列-Trench T Series					
GT50FF120T6H-M	1200	50	Trench FS	Page84 T6-FF	
GT75FF120T6H-M	1200	75	Trench FS	Page84 T6-FF	
GT100FF120T6H-M	1200	100	Trench FS	Page84 T6-FF	
GT150FF120T6H-M	1200	150	Trench FS	Page84 T6-FF	
GT200FF120T6H-M	1200	200	Trench FS	Page84 T6-FF	

Seven Pack (7单元IGBT模块)

A1

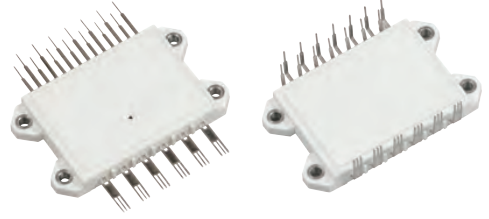
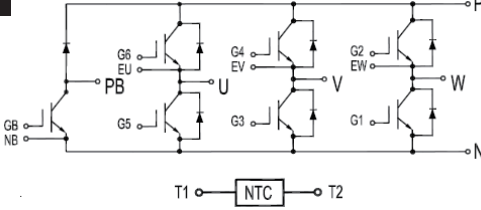

$V_{CES}=600V$

Part Number	Voltage(V)	Current(A)	Technology	Package Outline	Comments
标准型K系列-Standard K Series					
GK10FB60A1H	600	10	NPT	Page59 A1-FB	
GK20FB60A1H	600	20	NPT	Page59 A1-FB	
GK35FB60A1H	600	35	NPT	Page59 A1-FB	
GK50FB60A1H	600	50	NPT	Page59 A1-FB	
沟槽型T系列-Trench T Series					
GT50FB60A1H	600	50	Trench FS	Page59 A1-FB	
GT75FB60A1H	600	75	Trench FS	Page59 A1-FB	

$V_{CES}=1200V$

Part Number	Voltage(V)	Current(A)	Technology	Package Outline	Comments
沟槽型T系列-Trench T Series					
GT10FB120A1H	1200	10	Trench FS	Page59 A1-FB	
GT15FB120A1H	1200	15	Trench FS	Page59 A1-FB	
GT25FB120A1H	1200	25	Trench FS	Page59 A1-FB	
GT35FB120A1H	1200	35	Trench FS	Page59 A1-FB	
沟槽型T系列-Trench T Series					
GTS10FB120A1H	1200	10	Trench FS	Page59 A1-FB	
GTS15FB120A1H	1200	15	Trench FS	Page59 A1-FB	
GTS25FB120A1H	1200	25	Trench FS	Page59 A1-FB	
GTS40FB120A1H	1200	40	Trench FS	Page59 A1-FB	

Seven Pack (7单元IGBT模块)

B3

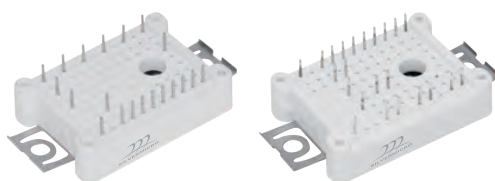
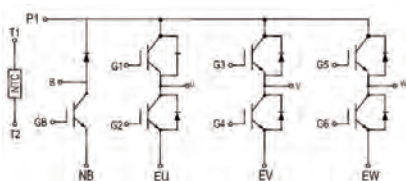

$V_{CES}=1200V$

Part Number	Voltage(V)	Current(A)	Technology	Package Outline	Comments
沟槽型T系列-Trench T Series					
GT10FB120B3H	1200	10	Trench FS	Page66 B3-FB	solder pins/pressfit pins
GT15FB120B3H	1200	15	Trench FS	Page66 B3-FB	solder pins/pressfit pins
沟槽型T系列-Trench T Series					
GTS10FB120B3H	1200	10	Trench FS	Page66 B3-FB	solder pins/pressfit pins
GTS15FB120B3H	1200	15	Trench FS	Page66 B3-FB	solder pins/pressfit pins

C7

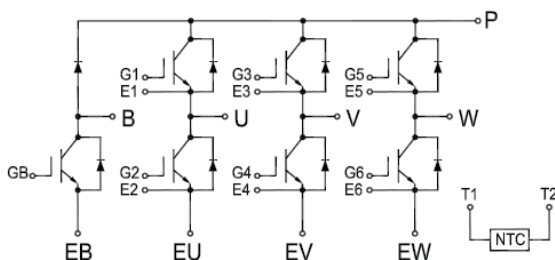

$V_{CES}=1200V$

Part Number	Voltage(V)	Current(A)	Technology	Package Outline	Comments
沟槽型T系列-Trench T Series					
GT25FB120C7H	1200	25	Trench FS	Page72 C7-FB	
GT40FB120C7H	1200	40	Trench FS	Page72 C7-FB	
GT50FB120C7H	1200	50	Trench FS	Page72 C7-FB	

H-Bridge (H 桥IGBT模块)

A1

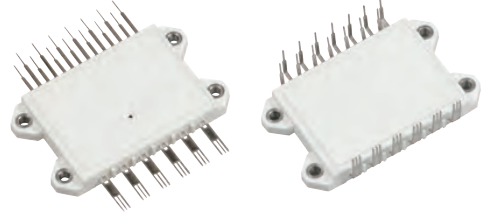
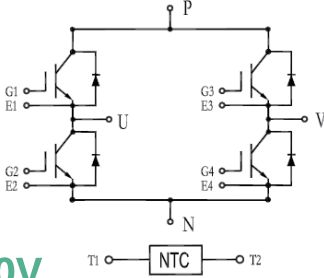

$V_{CES}=650V$

Part Number	Voltage(V)	Current(A)	Technology	Package Outline	Comments
沟槽型T系列-Trench T Series					
GT35HH65A1H	650	35	Trench FS	Page60 A1-HH	
GT50HH65A1H	650	50	Trench FS	Page60 A1-HH	
GT75HH65A1H	650	75	Trench FS	Page60 A1-HH	

$V_{CES}=1200V$

Part Number	Voltage(V)	Current(A)	Technology	Package Outline	Comments
沟槽型T系列-Trench T Series					
GT35HH120A1H	1200	35	Trench FS	Page60 A1-HH	
GT50HH120A1H	1200	50	Trench FS	Page60 A1-HH	
GT75HH120A1H	1200	75	Trench FS	Page60 A1-HH	

H-Bridge (H 桥IGBT模块)

A7B

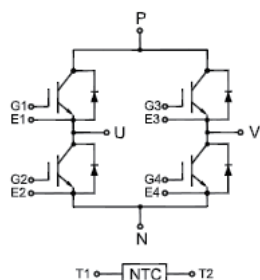

$V_{CES}=650V$

Part Number	Voltage(V)	Current(A)	Technology	Package Outline	Comments
沟槽型T系列-Trench T Series					
GT35HH65A7BH	650	35	Trench FS	Page62 A7B	
GT50HH65A7BH	650	50	Trench FS	Page62 A7B	

B3

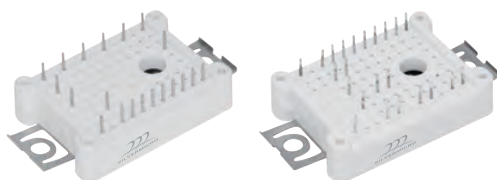
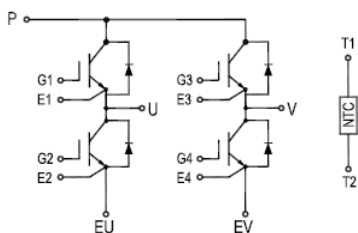

$V_{CES}=650V$

Part Number	Voltage(V)	Current(A)	Technology	Package Outline	Comments
沟槽型T系列-Trench T Series					
GT50HH65B3H	650	50	Trench FS	Page67 B3-HH	solder pins/pressfit pins
GT75HH65B3H	650	75	Trench FS	Page67 B3-HH	solder pins/pressfit pins

H-Bridge (H 桥IGBT模块)

C7

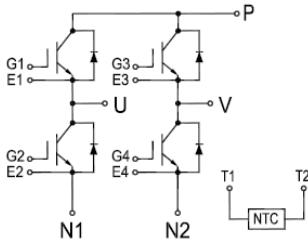

$V_{CES}=650V$

Part Number	Voltage(V)	Current(A)	Technology	Package Outline	Comments
沟槽型T系列-Trench T Series					
GT50HH65C7H	650	50	Trench FS	Page73 C7-HH	
GT75HH65C7H	650	75	Trench FS	Page73 C7-HH	
GT100HH65C7H	650	100	Trench FS	Page73 C7-HH	

$V_{CES}=1200V$

Part Number	Voltage(V)	Current(A)	Technology	Package Outline	Comments
沟槽型T系列-Trench T Series					
GT40HH120C7H	1200	40	Trench FS	Page73 C7-HH	
沟槽型T系列-Trench T Series					
GTM75HH120C7H	1200	75	Trench FS	Page73 C7-HH	

H-Bridge (H 桥IGBT模块)

T2

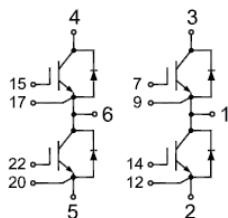

$V_{CES}=650V$

Part Number	Voltage(V)	Current(A)	Technology	Package Outline	Comments
沟槽型T系列-Trench T Series					
GT100HH65T2H	650	100	Trench FS	Page77 T2	
GT150HH65T2H	650	150	Trench FS	Page77 T2	
GT200HH65T2H	650	200	Trench FS	Page77 T2	

$V_{CES}=1200V$

Part Number	Voltage(V)	Current(A)	Technology	Package Outline	Comments
沟槽型T系列-Trench T Series					
GT50HH120T2H	1200	50	Trench FS	Page77 T2	
GT75HH120T2H	1200	75	Trench FS	Page77 T2	
GT100HH120T2H	1200	100	Trench FS	Page77 T2	
GT150HH120T2H	1200	150	Trench FS	Page77 T2	

H-Bridge (H 桥IGBT模块)

T5

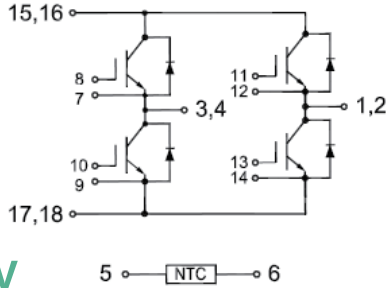

$V_{CES}=650V$

5 — NTC — 6

Part Number	Voltage(V)	Current(A)	Technology	Package Outline	Comments
沟槽型T系列-Trench T Series					
GT50HH65T5H	650	50	Trench FS	Page82 T5-HH	
GT75HH65T5H	650	75	Trench FS	Page82 T5-HH	
GT100HH65T5H	650	100	Trench FS	Page82 T5-HH	

$V_{CES}=1200V$

Part Number	Voltage(V)	Current(A)	Technology	Package Outline	Comments
沟槽型T系列-Trench T Series					
GT50HH120T5H	1200	50	Trench FS	Page82 T5-HH	
GT75HH120T5H	1200	75	Trench FS	Page82 T5-HH	
GT100HH120T5H	1200	100	Trench FS	Page82 T5-HH	

H-Bridge (H 桥IGBT模块)

T6

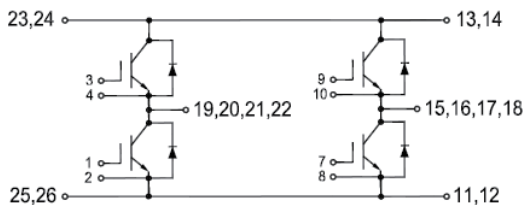

$V_{CES}=1200V$

Part Number	Voltage(V)	Current(A)	Technology	Package Outline	Comments
沟槽型T系列-Trench T Series					
GT150HH120T6H	1200	150	Trench FS	Page84 T6-HH	
GT200HH120T6H	1200	200	Trench FS	Page84 T6-HH	

Half Bridge (半桥IGBT模块)

A4

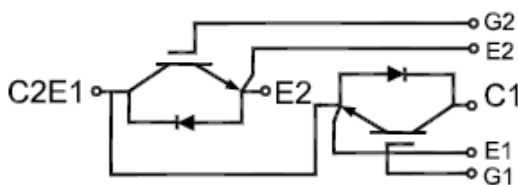

$V_{CES}=650V$

Part Number	Voltage(V)	Current(A)	Technology	Package Outline	Comments
沟槽型T系列-Trench T Series					
GT600HF65A4H	650	600	Trench FS	Page61 A4	

$V_{CES}=1200V$

Part Number	Voltage(V)	Current(A)	Technology	Package Outline	Comments
沟槽型T系列-Trench T Series					
GT600HF120A4H	1200	600	Trench FS	Page61 A4	
沟槽型T系列-Trench T Series					
GTS600HF120A4H	1200	600	Trench FS	Page61 A4	

Half Bridge (半桥IGBT模块)

A5

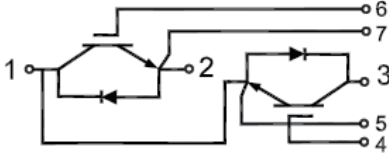

$V_{CES}=650V$

Part Number	Voltage(V)	Current(A)	Technology	Package Outline	Comments
沟槽型T系列-Trench T Series					
GTR200HF65A5H	650	200	Trench FS	Page61 A5	
GTR300HF65A5H	650	300	Trench FS	Page61 A5	
GTR400HF65A5H	650	400	Trench FS	Page61 A5	

$V_{CES}=1200V$

Part Number	Voltage(V)	Current(A)	Technology	Package Outline	Comments
沟槽型T系列-Trench T Series					
GT100HF120A5H-M	1200	100	Trench FS	Page61 A5	
GT150HF120A5H-M	1200	150	Trench FS	Page61 A5	
GT200HF120A5H-M	1200	200	Trench FS	Page61 A5	
GT300HF120A5H	1200	300	Trench FS	Page61 A5	
快速型F系列-Fast F Series					
GF100HF120A5H	1200	100	NPT	Page61 A5	
GF150HF120A5H	1200	150	NPT	Page61 A5	
GF200HF120A5H	1200	200	NPT	Page61 A5	

Half Bridge (半桥IGBT模块)

B1

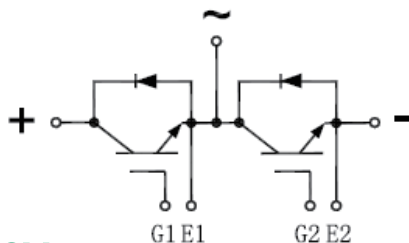

$V_{CES}=650V$

Part Number	Voltage(V)	Current(A)	Technology	Package Outline	Comments
沟槽型T系列-Trench T Series					
GT300HF65B1H	650	300	Trench FS	Page63 B1	
GT450HF65B1H	650	450	Trench FS	Page63 B1	
GT600HF65B1H	650	600	Trench FS	Page63 B1	

T1

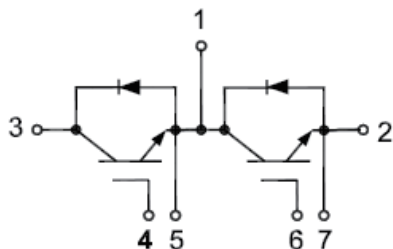

$V_{CES}=650V$

Part Number	Voltage(V)	Current(A)	Technology	Package Outline	Comments
沟槽型T系列-Trench T Series					
GT75HF65T1H	650	75	Trench FS	Page75 T1	
GT100HF65T1H	650	100	Trench FS	Page75 T1	
GT150HF65T1H	650	150	Trench FS	Page75 T1	
GT200HF65T1H	650	200	Trench FS	Page75 T1	

Half Bridge (半桥IGBT模块)

T1

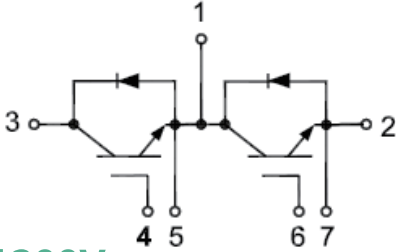

$V_{CES}=1200V$

Part Number	Voltage(V)	Current(A)	Technology	Package Outline	Comments
快速型F系列-Fast F Series					
GF40HF120T1H	1200	40	NPT	Page75 T1	
GF50HF120T1H	1200	50	NPT	Page75 T1	
GF75HF120T1H	1200	75	NPT	Page75 T1	
GF100HF120T1H	1200	100	NPT	Page75 T1	
沟槽型T系列-Trench T Series					
GT50HF120T1H-M	1200	50	Trench FS	Page75 T1	
GT75HF120T1H-M	1200	75	Trench FS	Page75 T1	
GT100HF120T1H-M	1200	100	Trench FS	Page75 T1	
GT150HF120T1H-M	1200	150	Trench FS	Page75 T1	

T1V

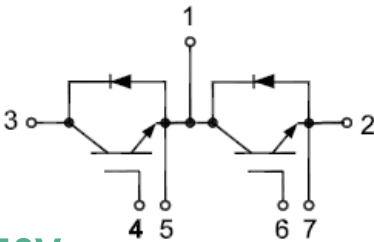

$V_{CES}=650V$

Part Number	Voltage(V)	Current(A)	Technology	Package Outline	Comments
沟槽型T系列-Trench T Series					
GT75HF65T1VH	650	75	Trench FS	Page75 T1V	
GT100HF65T1VH	650	100	Trench FS	Page75 T1V	
GT150HF65T1VH	650	150	Trench FS	Page75 T1V	
GT200HF65T1VH	650	200	Trench FS	Page75 T1V	

Half Bridge (半桥IGBT模块)

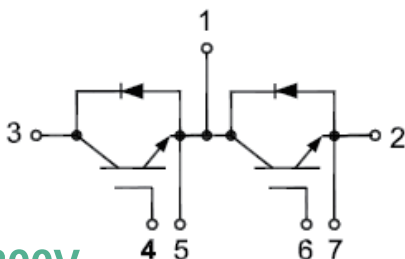
T1V

 $V_{CES}=1200V$

Part Number	Voltage(V)	Current(A)	Technology	Package Outline	Comments
快速型F系列-Fast F Series					
GF40HF120T1VH	1200	40	NPT	Page75 T1V	
GF50HF120T1VH	1200	50	NPT	Page75 T1V	
GF75HF120T1VH	1200	75	NPT	Page75 T1V	
GF100HF120T1VH	1200	100	NPT	Page75 T1V	
沟槽型T系列-Trench T Series					
GT50HF120T1VH-M	1200	50	Trench FS	Page75 T1V	
GT75HF120T1VH-M	1200	75	Trench FS	Page75 T1V	
GT100HF120T1VH-M	1200	100	Trench FS	Page75 T1V	
GT150HF120T1VH-M	1200	150	Trench FS	Page75 T1V	

 $V_{CES}=1700V$

Part Number	Voltage(V)	Current(A)	Technology	Package Outline	Comments
沟槽型T系列-Trench T Series					
GT100HF170T1VH	1700	100	Trench FS	Page75 T1V	

Half Bridge (半桥IGBT模块)

T1W

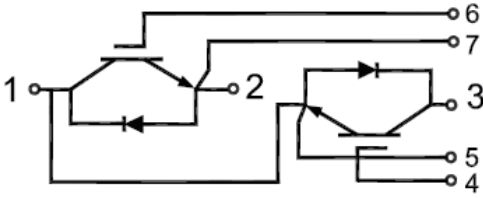

$V_{CES}=1200V$

Part Number	Voltage(V)	Current(A)	Technology	Package Outline	Comments
沟槽型T系列-Trench T Series					
GTS200HF120T1WH	1200	200	Trench FS	Page76 T1W	

T2V

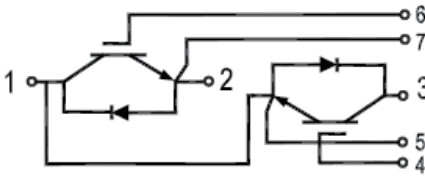

$V_{CES}=650V$

Part Number	Voltage(V)	Current(A)	Technology	Package Outline	Comments
沟槽型T系列-Trench T Series					
GT200HF65T2VH-M	650	200	Trench FS	Page79 T2V	
GT300HF65T2VH-M	650	300	Trench FS	Page79 T2V	
GT400HF65T2VH-M	650	400	Trench FS	Page79 T2V	

Half Bridge (半桥IGBT模块)

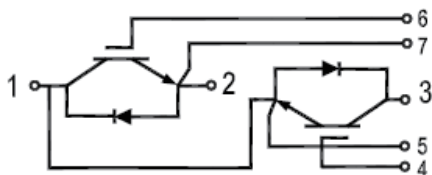
T2V

$V_{CES}=1200V$

Part Number	Voltage(V)	Current(A)	Technology	Package Outline	Comments
快速型F系列-Fast F Series					
GF100HF120T2VHE	1200	100	NPT	Page79 T2V	full current FWD
GF150HF120T2VHE	1200	150	NPT	Page79 T2V	full current FWD
GF200HF120T2VHE	1200	200	NPT	Page79 T2V	full current FWD
GF300HF120T2VHE	1200	300	NPT	Page79 T2V	full current FWD
沟槽型T系列-Trench T Series					
GT100HF120T2VH-M	1200	100	Trench FS	Page79 T2V	
GT150HF120T2VH-M	1200	150	Trench FS	Page79 T2V	
GT200HF120T2VH-M	1200	200	Trench FS	Page79 T2V	
GT300HF120T2VH-M	1200	300	Trench FS	Page79 T2V	
GT400HF120T2VH-M	1200	400	Trench FS	Page79 T2V	

$V_{CES}=1700V$

Part Number	Voltage(V)	Current(A)	Technology	Package Outline	Comments
沟槽型T系列-Trench T Series					
GT150HF170T2VH	1700	150	Trench FS	Page79 T2V	
GT200HF170T2VH	1700	200	Trench FS	Page79 T2V	
GT300HF170T2VH	1700	300	Trench FS	Page79 T2V	

Half Bridge (半桥IGBT模块)

T2N

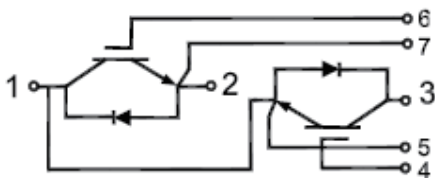

$V_{CES}=650V$

Part Number	Voltage(V)	Current(A)	Technology	Package Outline	Comments
沟槽型T系列-Trench T Series					
GT450HF65T2NH-M	650	450	Trench FS	Page78 T2N	
GT600HF65T2NH-M	650	600	Trench FS	Page78 T2N	

$V_{CES}=1200V$

Part Number	Voltage(V)	Current(A)	Technology	Package Outline	Comments
快速型F系列-Fast F Series					
GF300HF120T2NHE	1200	300	NPT	Page78 T2N	full current FWD
沟槽型T系列-Trench T Series					
GT450HF120T2NH-M	1200	450	Trench FS	Page78 T2N	

$V_{CES}=1700V$

Part Number	Voltage(V)	Current(A)	Technology	Package Outline	Comments
沟槽型T系列-Trench T Series					
GT200HF170T2NH	1700	200	Trench FS	Page78 T2N	
GT300HF170T2NH	1700	300	Trench FS	Page78 T2N	

Half Bridge (半桥IGBT模块)

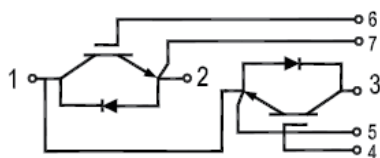
T2L

$V_{CES}=650V$

Part Number	Voltage(V)	Current(A)	Technology	Package Outline	Comments
沟槽型T系列-Trench T Series					
GTR450HF65T2LH	650	450	Trench FS	Page77 T2L	
GTR600HF65T2LH	650	600	Trench FS	Page77 T2L	

$V_{CES}=1200V$

Part Number	Voltage(V)	Current(A)	Technology	Package Outline	Comments
快速型F系列-Fast F Series					
GF300HF120T2LH	1200	300	NPT	Page77 T2L	full current FWD
沟槽型T系列-Trench T Series					
GT450HF120T2LH	1200	450	Trench FS	Page77 T2L	

$V_{CES}=1700V$

Part Number	Voltage(V)	Current(A)	Technology	Package Outline	Comments
沟槽型T系列-Trench T Series					
GT200HF170T2LH	1700	200	Trench FS	Page77 T2L	
GT300HF170T2LH	1700	300	Trench FS	Page77 T2L	

Half Bridge (半桥IGBT模块)

T8

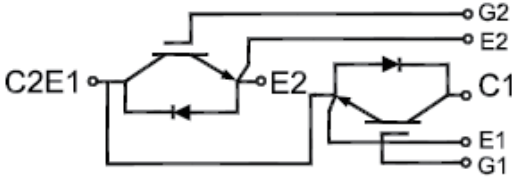

$V_{CES}=650V$

Part Number	Voltage(V)	Current(A)	Technology	Package Outline	Comments
沟槽型T系列-Trench T Series					
GT600HF65T8H	650	600	Trench FS	Page86 T8	

$V_{CES}=1200V$

Part Number	Voltage(V)	Current(A)	Technology	Package Outline	Comments
沟槽型T系列-Trench T Series					
GT600HF120T8H	1200	600	Trench FS	Page86 T8	
沟槽型T系列-Trench T Series					
GTS600HF120T8H	1200	600	Trench FS	Page86 T8	

Half Bridge (半桥IGBT模块)

T9

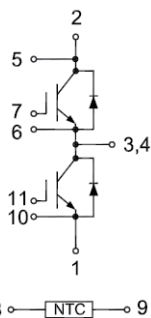

$V_{CES}=650V$

Part Number	Voltage(V)	Current(A)	Technology	Package Outline	Comments
沟槽型T系列-Trench T Series					
GT300HF65T9H	650	300	Trench FS	Page87 T9	
GT450HF65T9H	650	450	Trench FS	Page87 T9	
GT600HF65T9H	650	600	Trench FS	Page87 T9	

$V_{CES}=1200V$

Part Number	Voltage(V)	Current(A)	Technology	Package Outline	Comments
沟槽型T系列-Trench T Series					
GT225HF120T9H-M	1200	225	Trench FS	Page87 T9	
GT300HF120T9H-M	1200	300	Trench FS	Page87 T9	
GT450HF120T9H-M	1200	450	Trench FS	Page87 T9	
GT600HF120T9H-M	1200	600	Trench FS	Page87 T9	

Half Bridge (半桥IGBT模块)

T9

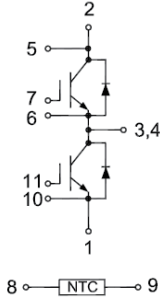

$V_{CES}=1700V$

Part Number	Voltage(V)	Current(A)	Technology	Package Outline	Comments
沟槽型T系列-Trench T Series					
GT300HF170T9H	1700	300	Trench FS	Page87 T9	
GT450HF170T9H	1700	450	Trench FS	Page87 T9	
GT600HF170T9H	1700	600	Trench FS	Page87 T9	

Half Bridge (半桥IGBT模块)

P3

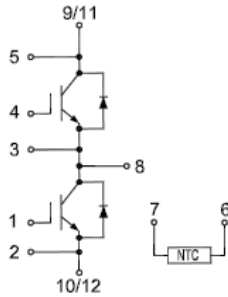

$V_{CES}=1700V$

Part Number	Voltage(V)	Current(A)	Technology	Package Outline	Comments
沟槽型T系列-Trench T Series					
GT1000HF170P3H	1700	1000	Trench FS	Page74 P3	

Single (单管IGBT模块)

A2

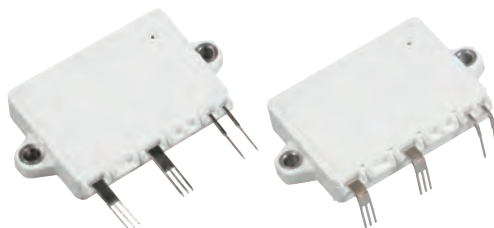
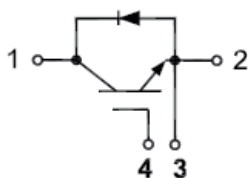
 $V_{CES}=650V$

Part Number	Voltage(V)	Current(A)	Technology	Package Outline	Comments
沟槽型T系列-Trench T Series					
GT400SD65A2H	650	400	Trench FS	Page60 A2-SD	

 $V_{CES}=1200V$

Part Number	Voltage(V)	Current(A)	Technology	Package Outline	Comments
沟槽型T系列-Trench T Series					
GT75SD120A2H	1200	75	Trench FS	Page60 A2-SD	
GT100SD120A2H	1200	100	Trench FS	Page60 A2-SD	
GT150SD120A2H	1200	150	Trench FS	Page60 A2-SD	
标准型K系列-Standard K Series					
GK100SD120A2H	1200	100	NPT	Page60 A2-SD	

 $V_{CES}=1700V$

Part Number	Voltage(V)	Current(A)	Technology	Package Outline	Comments
沟槽型T系列-Trench T Series					
GT100SD170A2H	1700	100	Trench FS	Page60 A2-SD	
GT200SD170A2H	1700	200	Trench FS	Page60 A2-SD	

Single (单管IGBT模块)

B5

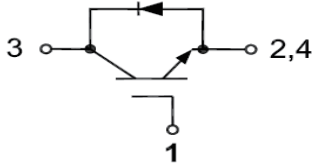

$V_{CES}=1200V$

Part Number	Voltage(V)	Current(A)	Technology	Package Outline	Comments
沟槽型T系列-Trench T Series					
GT50SD120B5H	1200	50	Trench FS	Page69 B5	
GT75SD120B5H	1200	75	Trench FS	Page69 B5	
GT100SD120B5H	1200	100	Trench FS	Page69 B5	

T2Z

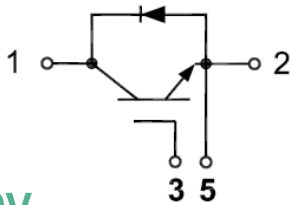

$V_{CES}=650V$

Part Number	Voltage(V)	Current(A)	Technology	Package Outline	Comments
沟槽型T系列-Trench T Series					
GT200SD65T2ZH-M	650	200	Trench FS	Page79 T2Z	
GT300SD65T2ZH-M	650	300	Trench FS	Page79 T2Z	
GT400SD65T2ZH-M	650	400	Trench FS	Page79 T2Z	
GT600SD65T2ZH-M	650	600	Trench FS	Page79 T2Z	
GT800SD65T2ZH-M	650	800	Trench FS	Page79 T2Z	
GT900SD65T2ZH-M	650	900	Trench FS	Page79 T2Z	

Single (单管IGBT模块)

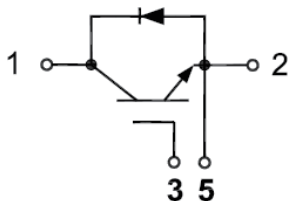
T2Z

$V_{CES}=1200V$

Part Number	Voltage(V)	Current(A)	Technology	Package Outline	Comments
沟槽型T系列-Trench T Series					
GT200SD120T2ZH-M	1200	200	Trench FS	Page79 T2Z	
GT300SD120T2ZH-M	1200	300	Trench FS	Page79 T2Z	
GT400SD120T2ZH-M	1200	400	Trench FS	Page79 T2Z	
GT600SD120T2ZH-M	1200	600	Trench FS	Page79 T2Z	
GT800SD120T2ZH-M	1200	800	Trench FS	Page79 T2Z	
GT900SD120T2ZH-M	1200	900	Trench FS	Page79 T2Z	
快速型F系列-Fast F Series					
GF200SD120T2ZH	1200	200	NPT	Page79 T2Z	
GF300SD120T2ZH	1200	300	NPT	Page79 T2Z	
GF400SD120T2ZH	1200	400	NPT	Page79 T2Z	
GF600SD120T2ZH	1200	600	NPT	Page79 T2Z	

$V_{CES}=1700V$

Part Number	Voltage(V)	Current(A)	Technology	Package Outline	Comments
沟槽型T系列-Trench T Series					
GT300SD170T2ZH	1700	300	Trench	Page79 T2Z	

Single (单管IGBT模块)

T3

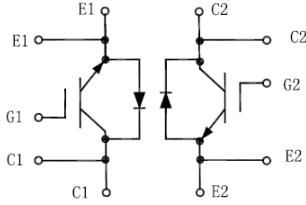

$V_{CES}=1200V$

Part Number	Voltage(V)	Current(A)	Technology	Package Outline	Comments
沟槽型T系列-Trench T Series					
GT900DSD120T3H	1200	900	Trench FS	Page80 T3	
GT1200DSD120T3H	1200	1200	Trench FS	Page80 T3	

$V_{CES}=1700V$

Part Number	Voltage(V)	Current(A)	Technology	Package Outline	Comments
沟槽型T系列-Trench T Series					
GT600DSD170T3H	1700	600	Trench FS	Page80 T3	
GT900DSD170T3H	1700	900	Trench FS	Page80 T3	
GT1200DSD170T3H	1700	1200	Trench FS	Page80 T3	

T4

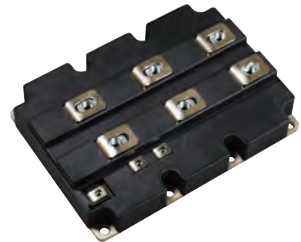
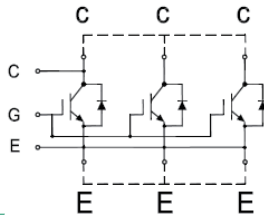

$V_{CES}=1200V$

Part Number	Voltage(V)	Current(A)	Technology	Package Outline	Comments
沟槽型T系列-Trench T Series					
GT2400SD120T4H	1200	2400	Trench FS	Page80 T4	
GT3600SD120T4H	1200	3600	Trench FS	Page80 T4	

Single (单管IGBT模块)

T4

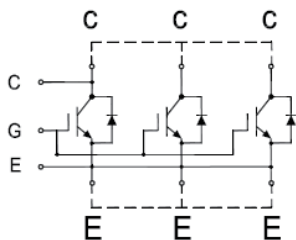

$V_{CES}=1700V$

Part Number	Voltage(V)	Current(A)	Technology	Package Outline	Comments
沟槽型T系列-Trench T Series					
GT2400SD170T4H	1700	2400	Trench	Page80 T4	
GT3600SD170T4H	1700	3600	Trench	Page80 T4	

Chopper (斩波IGBT模块)

A5

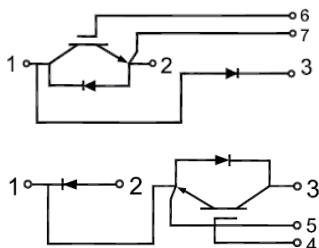

$V_{CES}=1200V$

Part Number	Voltage(V)	Current(A)	Technology	Package Outline	Comments
沟槽型T系列-Trench T Series					
GT100CU120A5H-M	1200	100	Trench FS	Page61 A5	
GT150CU120A5H-M	1200	150	Trench FS	Page61 A5	
GT200CU120A5H-M	1200	200	Trench FS	Page61 A5	
GT300CU120A5H-M	1200	300	Trench FS	Page61 A5	
沟槽型T系列-Trench T Series					
GT100CL120A5H-M	1200	100	Trench FS	Page61 A5	
GT150CL120A5H-M	1200	150	Trench FS	Page61 A5	
GT200CL120A5H-M	1200	200	Trench FS	Page61 A5	
GT300CL120A5H-M	1200	300	Trench FS	Page61 A5	

Chopper (斩波IGBT模块)

A8

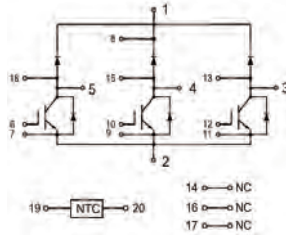
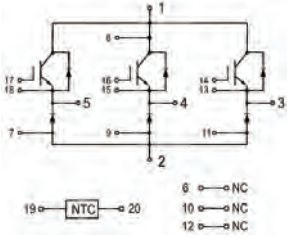

$V_{CES}=650V$

Part Number	Voltage(V)	Current(A)	Technology	Package Outline	Comments
沟槽型T系列-Trench T Series					
GT200DF65A8H	650	200	Trench FS	Page63 A8	
GT300DF65A8H	650	300	Trench FS	Page63 A8	
GT400DF65A8H	650	400	Trench FS	Page63 A8	
沟槽型T系列-Trench T Series					
GT200FD65A8H	650	200	Trench FS	Page63 A8	
GT300FD65A8H	650	300	Trench FS	Page63 A8	
GT400FD65A8H	650	400	Trench FS	Page63 A8	

$V_{CES}=1200V$

Part Number	Voltage(V)	Current(A)	Technology	Package Outline	Comments
沟槽型T系列-Trench T Series					
GT100DF120A8H	1200	100	Trench FS	Page63 A8	
GT150DF120A8H	1200	150	Trench FS	Page63 A8	
GT200DF120A8H	1200	200	Trench FS	Page63 A8	
沟槽型T系列-Trench T Serie					
GT100FD120A8H	1200	100	Trench FS	Page63 A8	
GT150FD120A8H	1200	150	Trench FS	Page63 A8	
GT200FD120A8H	1200	200	Trench FS	Page63 A8	

Chopper (斩波IGBT模块)

B2

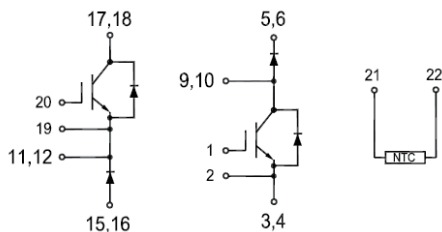

$V_{CES}=650V$

Part Number	Voltage(V)	Current(A)	Technology	Package Outline	Comments
沟槽型T系列-Trench T Series					
GT50CH65B2H	650	50	Trench FS	Page64 B2-CH	2-clip
GT75CH65B2H	650	75	Trench FS	Page64 B2-CH	2-clip

B5

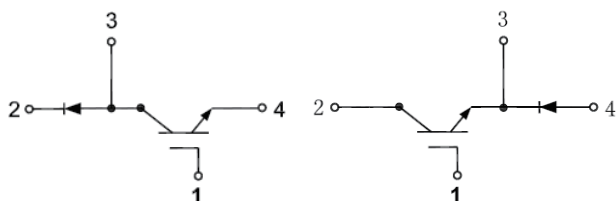

$V_{CES}=1200V$

Part Number	Voltage(V)	Current(A)	Technology	Package Outline	Comments
沟槽型T系列-Trench T Series					
GT50CU120B5H	1200	50	Trench FS	Page69 B5	
GT75CU120B5H	1200	75	Trench FS	Page69 B5	
GT100CU120B5H	1200	100	Trench FS	Page69 B5	
沟槽型T系列-Trench T Series					
GT50CL120B5H	1200	50	Trench FS	Page69 B5	
GT75CL120B5H	1200	75	Trench FS	Page69 B5	
GT100CL120B5H	1200	100	Trench FS	Page69 B5	

Chopper (斩波IGBT模块)

T1

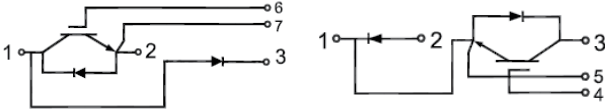

$V_{CES}=1200V$

Part Number	Voltage(V)	Current(A)	Technology	Package Outline	Comments
沟槽型T系列-Trench T Series					
GT50CU120T1H-M	1200	50	Trench FS	Page75 T1	
GT75CU120T1H-M	1200	75	Trench FS	Page75 T1	
GT100CU120T1H-M	1200	100	Trench FS	Page75 T1	
GT150CU120T1H-M	1200	150	Trench FS	Page75 T1	
沟槽型T系列-Trench T Series					
GT50CL120T1H-M	1200	50	Trench FS	Page75 T1	
GT75CL120T1H-M	1200	75	Trench FS	Page75 T1	
GT100CL120T1H-M	1200	100	Trench FS	Page75 T1	
GT150CL120T1H-M	1200	150	Trench FS	Page75 T1	

T1V

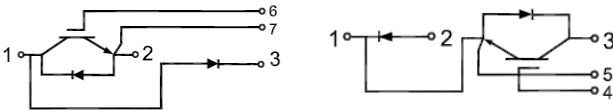

$V_{CES}=1200V$

Part Number	Voltage(V)	Current(A)	Technology	Package Outline	Comments
沟槽型T系列-Trench T Series					
GT50CU120T1VH-M	1200	50	Trench FS	Page75 T1V	
GT75CU120T1VH-M	1200	75	Trench FS	Page75 T1V	
GT100CU120T1VH-M	1200	100	Trench FS	Page75 T1V	
GT150CU120T1VH-M	1200	150	Trench FS	Page75 T1V	
沟槽型T系列-Trench T Series					
GT50CL120T1VH-M	1200	50	Trench FS	Page75 T1V	
GT75CL120T1VH-M	1200	75	Trench FS	Page75 T1V	
GT100CL120T1VH-M	1200	100	Trench FS	Page75 T1V	
GT150CL120T1VH-M	1200	150	Trench FS	Page75 T1V	

Chopper (斩波IGBT模块)

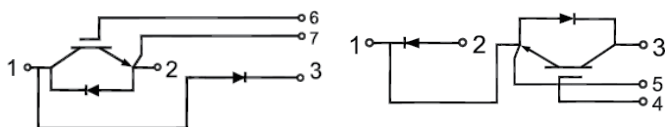
T2V

$V_{CES} = 1200V$

Part Number	Voltage(V)	Current(A)	Technology	Package Outline	Comments
沟槽型T系列-Trench T Series					
GT100CU120T2VH-M	1200	100	Trench FS	Page91 T2V	
GT150CU120T2VH-M	1200	150	Trench FS	Page91 T2V	
GT200CU120T2VH-M	1200	200	Trench FS	Page91 T2V	
GT300CU120T2VH-M	1200	300	Trench FS	Page91 T2V	
GT400CU120T2VH-M	1200	400	Trench FS	Page91 T2V	
沟槽型T系列-Trench T Series					
GT100CL120T2VH-M	1200	100	Trench FS	Page91 T2V	
GT150CL120T2VH-M	1200	150	Trench FS	Page91 T2V	
GT200CL120T2VH-M	1200	200	Trench FS	Page91 T2V	
GT300CL120T2VH-M	1200	300	Trench FS	Page91 T2V	
GT400CL120T2VH-M	1200	400	Trench FS	Page91 T2V	

$V_{CES} = 1700V$

Part Number	Voltage(V)	Current(A)	Technology	Package Outline	Comments
沟槽型T系列-Trench T Series					
GT100CU170T2VH	1700	100	Trench FS	Page79 T2V	
GT150CU170T2VH	1700	150	Trench FS	Page79 T2V	
GT200CU170T2VH	1700	200	Trench FS	Page79 T2V	
GT300CU170T2VH	1700	300	Trench FS	Page79 T2V	
沟槽型T系列-Trench T Series					
GT100CL170T2VH	1700	100	Trench FS	Page79 T2V	
GT150CL170T2VH	1700	150	Trench FS	Page79 T2V	
GT200CL170T2VH	1700	200	Trench FS	Page79 T2V	
GT300CL170T2VH	1700	300	Trench FS	Page79 T2V	

Chopper (斩波IGBT模块)

T2N

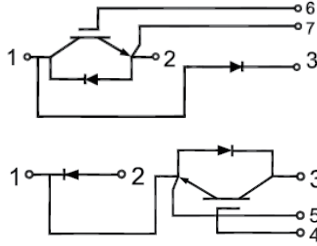

$V_{CES}=1200V$

Part Number	Voltage(V)	Current(A)	Technology	Package Outline	Comments
沟槽型T系列-Trench T Series					
GT450CU120T2NH-M	1200	450	Trench FS	Page78 T2N	
沟槽型T系列-Trench T Series					
GT450CL120T2NH-M	1200	450	Trench FS	Page78 T2N	

T2

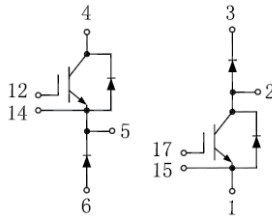

$V_{CES}=1200V$

Part Number	Voltage(V)	Current(A)	Technology	Package Outline	Comments
沟槽型T系列-Trench T Series					
GT75CH120T2H	1200	75	Trench FS	Page76 T2	
GT100CH120T2H	1200	100	Trench FS	Page76 T2	
GT150CH120T2H	1200	150	Trench FS	Page76 T2	
GT200CH120T2H	1200	200	Trench FS	Page76 T2	

Chopper (斩波IGBT模块)

T5

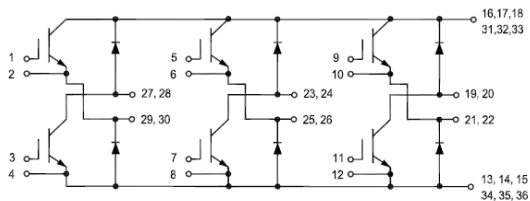

$V_{CES}=1200V$

Part Number	Voltage(V)	Current(A)	Technology	Package Outline	Comments
沟槽型T系列-Trench T Series					
GT50CZ120T5H	1200	50	Trench FS	Page81 T5-CZ	
GT75CZ120T5H	1200	75	Trench FS	Page81 T5-CZ	

T6

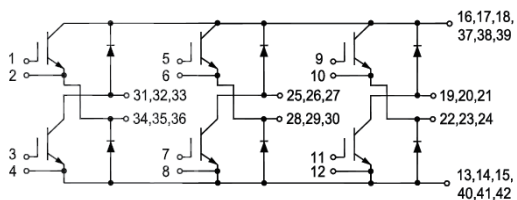

$V_{CES}=650V$

Part Number	Voltage(V)	Current(A)	Technology	Package Outline	Comments
沟槽型T系列-Trench T Series					
GT75CZ65T6H	650	75	Trench FS	Page83 T6-CZ	
GT100CZ65T6H	650	100	Trench FS	Page83 T6-CZ	
GT150CZ65T6H	650	150	Trench FS	Page83 T6-CZ	
GT200CZ65T6H	650	200	Trench FS	Page83 T6-CZ	

$V_{CES}=1200V$

Part Number	Voltage(V)	Current(A)	Technology	Package Outline	Comments
沟槽型T系列-Trench T Series					
GT50CZ120T6H-M	1200	50	Trench FS	Page83 T6-CZ	
GT75CZ120T6H-M	1200	75	Trench FS	Page83 T6-CZ	
GT100CZ120T6H-M	1200	100	Trench FS	Page83 T6-CZ	
GT150CZ120T6H-M	1200	150	Trench FS	Page83 T6-CZ	
GT200CZ120T6H-M	1200	200	Trench FS	Page83 T6-CZ	

Chopper (斩波IGBT模块)

T9

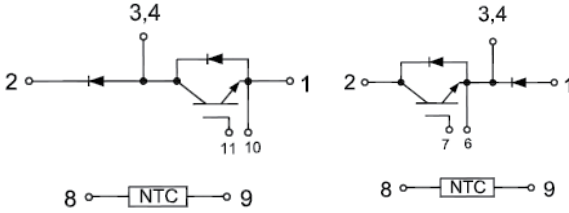

$V_{CES}=650V$

Part Number	Voltage(V)	Current(A)	Technology	Package Outline	Comments
沟槽型T系列-Trench T Series					
GT225CU65T9H-M	650	225	Trench FS	Page87 T9	
GT300CU65T9H-M	650	300	Trench FS	Page87 T9	
GT450CU65T9H-M	650	450	Trench FS	Page87 T9	
GT600CU65T9H-M	650	600	Trench FS	Page87 T9	
沟槽型T系列-Trench T Series					
GT225CL65T9H-M	650	225	Trench FS	Page87 T9	
GT300CL65T9H-M	650	300	Trench FS	Page87 T9	
GT450CL65T9H-M	650	450	Trench FS	Page87 T9	
GT600CL65T9H-M	650	600	Trench FS	Page87 T9	

$V_{CES}=1200V$

Part Number	Voltage(V)	Current(A)	Technology	Package Outline	Comments
沟槽型T系列-Trench T Series					
GT225CU120T9H-M	1200	225	Trench FS	Page87 T9	
GT300CU120T9H-M	1200	300	Trench FS	Page87 T9	
GT450CU120T9H-M	1200	450	Trench FS	Page87 T9	
GT600CU120T9H-M	1200	600	Trench FS	Page87 T9	
沟槽型T系列-Trench T Series					
GT225CL120T9H-M	1200	225	Trench FS	Page87 T9	
GT300CL120T9H-M	1200	300	Trench FS	Page87 T9	
GT450CL120T9H-M	1200	450	Trench FS	Page87 T9	
GT600CL120T9H-M	1200	600	Trench FS	Page87 T9	
沟槽型T系列-Trench T Series					
GT225CH120T9-M	1200	225	Trench FS	Page87 T9	
GT300CH120T9-M	1200	300	Trench FS	Page87 T9	
GT450CH120T9-M	1200	450	Trench FS	Page87 T9	
GT600CH120T9-M	1200	600	Trench FS	Page87 T9	

Three level (三电平IGBT模块)

A8

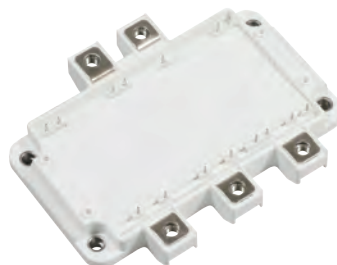
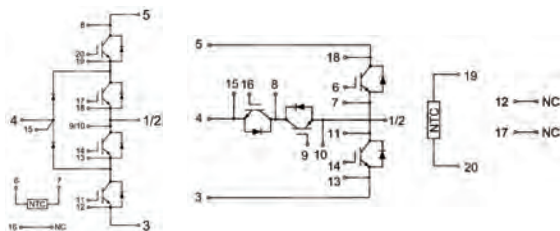

$V_{CES}=650V$

Part Number	Voltage(V)	Current(A)	Technology	Package Outline	Comments
沟槽型T系列-Trench T Series					
GT150TL65A8H	650	150	Trench FS	Page63 A8	
GT200TL65A8H	650	200	Trench FS	Page63 A8	
GT300TL65A8H	650	300	Trench FS	Page63 A8	
GT400TL65A8H	650	400	Trench FS	Page63 A8	
GT500TL65A8H	650	500	Trench FS	Page63 A8	
沟槽型T系列-Trench T Series					
GT150TT65A8H	650	150	Trench FS	Page63 A8	
GT200TT65A8H	650	200	Trench FS	Page63 A8	
GT300TT65A8H	650	300	Trench FS	Page63 A8	
GT400TT65A8H	650	400	Trench FS	Page63 A8	
GT500TT65A8H	650	500	Trench FS	Page63 A8	

$V_{CES}=1200V$

Part Number	Voltage(V)	Current(A)	Technology	Package Outline	Comments
沟槽型T系列-Trench T Series					
GT150TL120A8H	1200	150	Trench FS	Page63 A8	
GT200TL120A8H	1200	200	Trench FS	Page63 A8	
GT300TL120A8H	1200	300	Trench FS	Page63 A8	
沟槽型T系列-Trench T Series					
GT150TT120A8H	1200	150	Trench FS	Page63 A8	
GT200TT120A8H	1200	200	Trench FS	Page63 A8	
GT300TT120A8H	1200	300	Trench FS	Page63 A8	

Three level (三电平IGBT模块)

B2

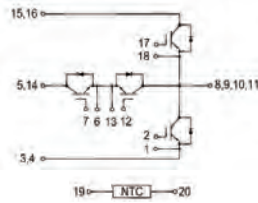
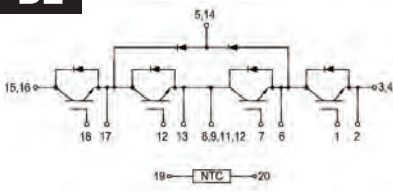

$V_{CES}=650V$

Part Number	Voltage(V)	Current(A)	Technology	Package Outline	Comments
沟槽型T系列-Trench T Series					
GT50TL65B2H	650	50	Trench FS	Page65 B2-TL	2-clip
GT75TL65B2H	650	75	Trench FS	Page65 B2-TL	2-clip

$V_{CES}=650V$

Part Number	Voltage(V)	Current(A)	Technology	Package Outline	Comments
沟槽型T系列-Trench T Series					
GT50TT65B2H	650	50	Trench FS	Page66 B2-TT	2-clip
GT75TT65B2H	650	75	Trench FS	Page66 B2-TT	2-clip

B3

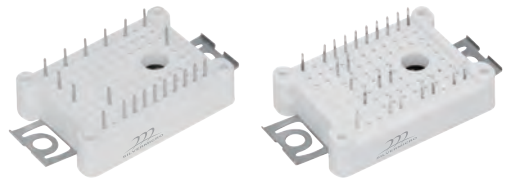
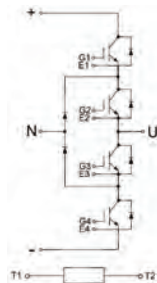

$V_{CES}=650V$

Part Number	Voltage(V)	Current(A)	Technology	Package Outline	Comments
沟槽型T系列-Trench T Series					
GT50TL65B3H	650	50	Trench FS	Page68 B3-TL	solder pins/presfit pins
GT75TL65B3H	650	75	Trench FS	Page68 B3-TL	solder pins/presfit pins

Three level (三电平IGBT模块)

B9

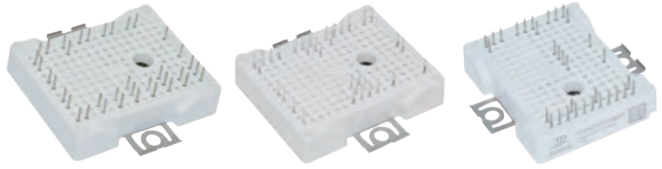
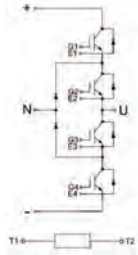

$V_{CES}=650V$

Part Number	Voltage(V)	Current(A)	Technology	Package Outline	Comments
沟槽型T系列-Trench T Series					
GTM100TL65B9H	650	100	Trench FS	Page70 B9-TL	solder pins/presfit pins
GTM150TL65B9H	650	150	Trench FS	Page70 B9-TL	solder pins/presfit pins

$V_{CES}=1200V$

Part Number	Voltage(V)	Current(A)	Technology	Package Outline	Comments
沟槽型T系列-Trench T Series					
GT75TL120B9H	1200	75	Trench FS	Page70 B9-TL	solder pins/presfit pins
GT100TL120B9H	1200	100	Trench FS	Page70 B9-TL	solder pins/presfit pins

Three level (三电平IGBT模块)

T2S

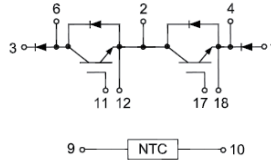
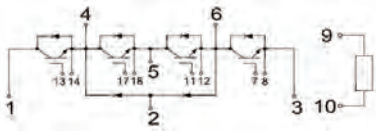

$V_{CES}=650V$

Part Number	Voltage(V)	Current(A)	Technology	Package Outline	Comments
沟槽型T系列-Trench T Series					
GTR150TL65T2SH	650	150	Trench FS	Page78 T2S	
GTR200TL65T2SH	650	200	Trench FS	Page78 T2S	
GTR300TL65T2SH	650	300	Trench FS	Page78 T2S	
沟槽型T系列-Trench T Series					
GTR150TAR65T2SH	650	150	Trench FS	Page78 T2S	
GTR200TAR65T2SH	650	200	Trench FS	Page78 T2S	
GTR300TAR65T2SH	650	300	Trench FS	Page78 T2S	
GTR400TAR65T2SH	650	400	Trench FS	Page78 T2S	

$V_{CES}=1200V$

Part Number	Voltage(V)	Current(A)	Technology	Package Outline	Comments
沟槽型T系列-Trench T Series					
GT100TL120T2SH	1200	100	Trench FS	Page78 T2S	
GT150TL120T2SH	1200	150	Trench FS	Page78 T2S	
GT200TL120T2SH	1200	200	Trench FS	Page78 T2S	

Three level (三电平IGBT模块)

T7

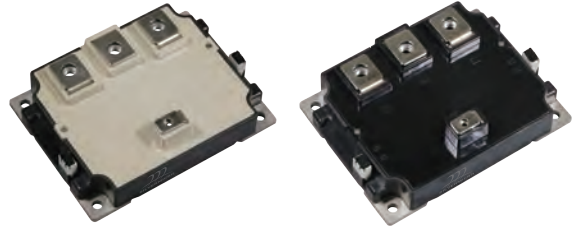
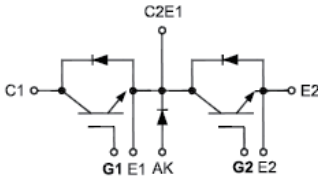

$V_{CES}=650V$

Part Number	Voltage(V)	Current(A)	Technology	Package Outline	Comments
沟槽型T系列-Trench T Series					
GT600TL65T7H-N	650	600	Trench FS	Page86 T7	
沟槽型T系列-Trench T Series					
GT600TL65T7H-P	650	600	Trench FS	Page86 T7	

T9

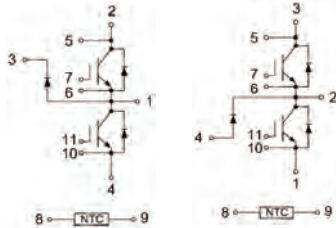

$V_{CES}=1200V$

Part Number	Voltage(V)	Current(A)	Technology	Package Outline	Comments
沟槽型T系列-Trench T Series					
GT200MAR120T9H	1200	200	Trench FS	Page87 T9	
GT300MAR120T9H	1200	300	Trench FS	Page87 T9	
沟槽型T系列-Trench T Series					
GT200MCR120T9H	1200	200	Trench FS	Page87 T9	
GT300MCR120T9H	1200	300	Trench FS	Page87 T9	

A1-FB

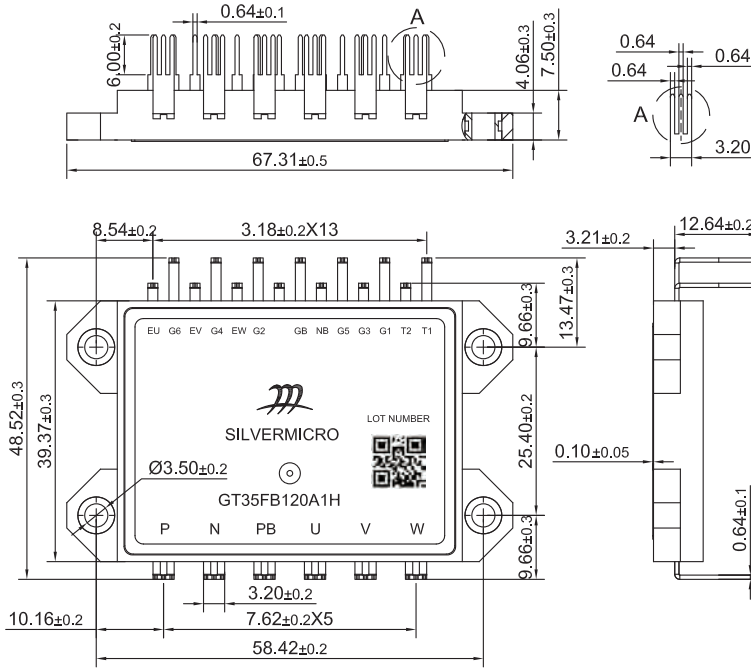

A1-FF

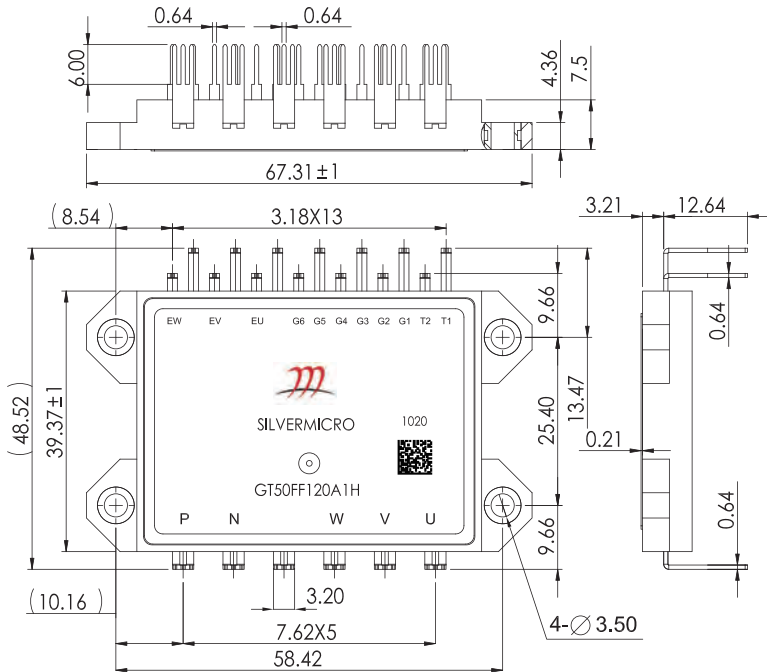

A1-HH

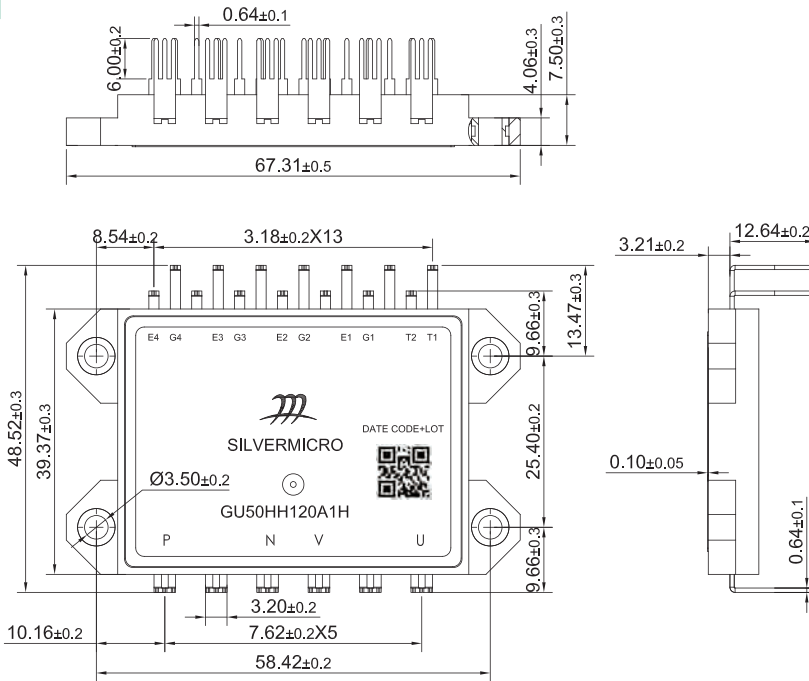

A2-SD

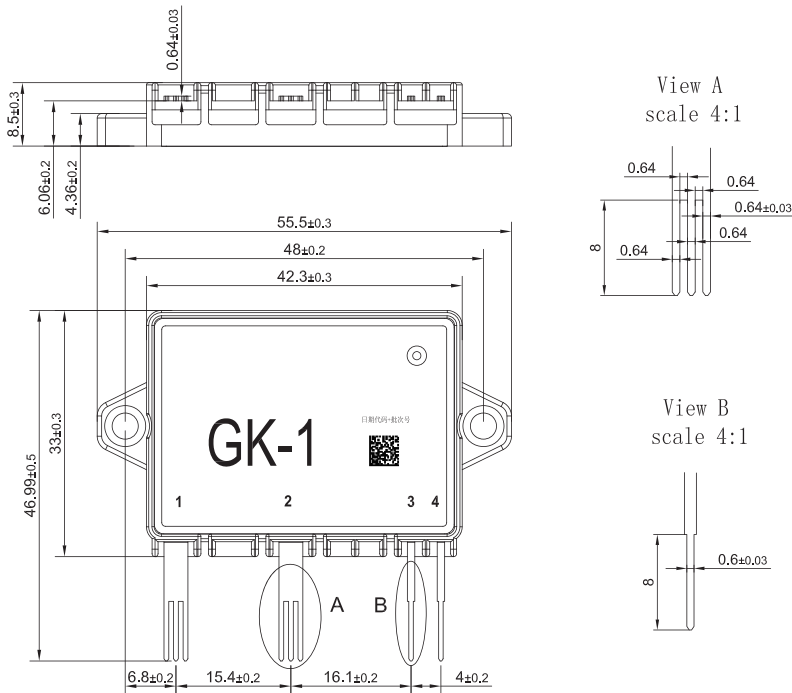

A4

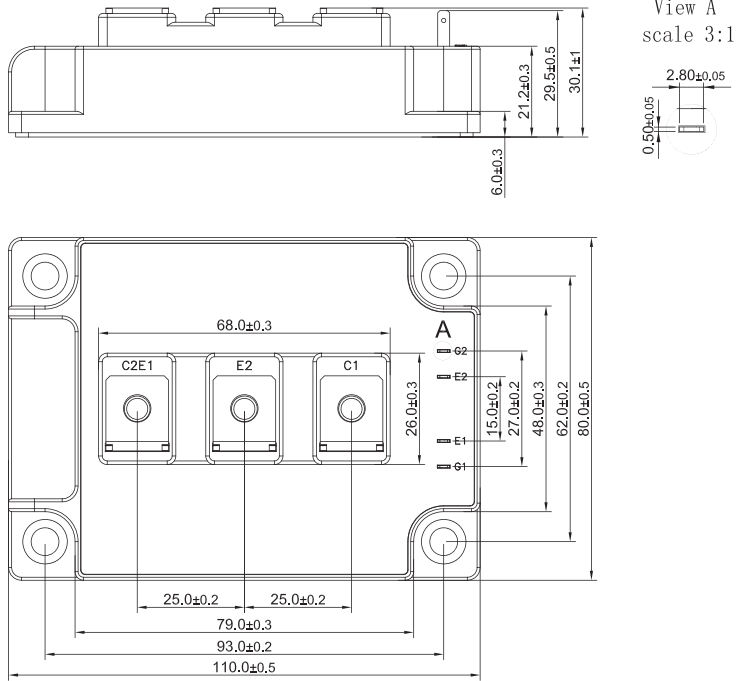

A5

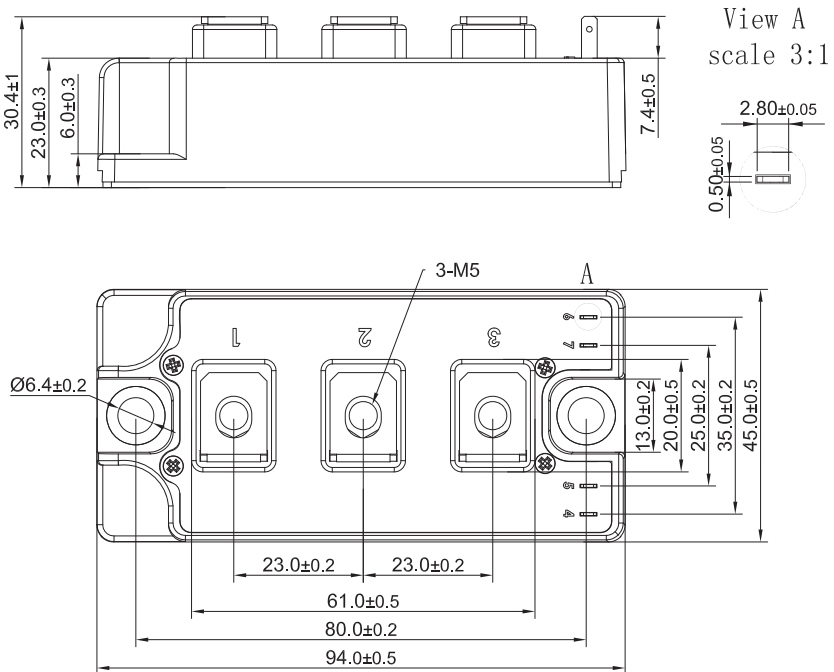

A6

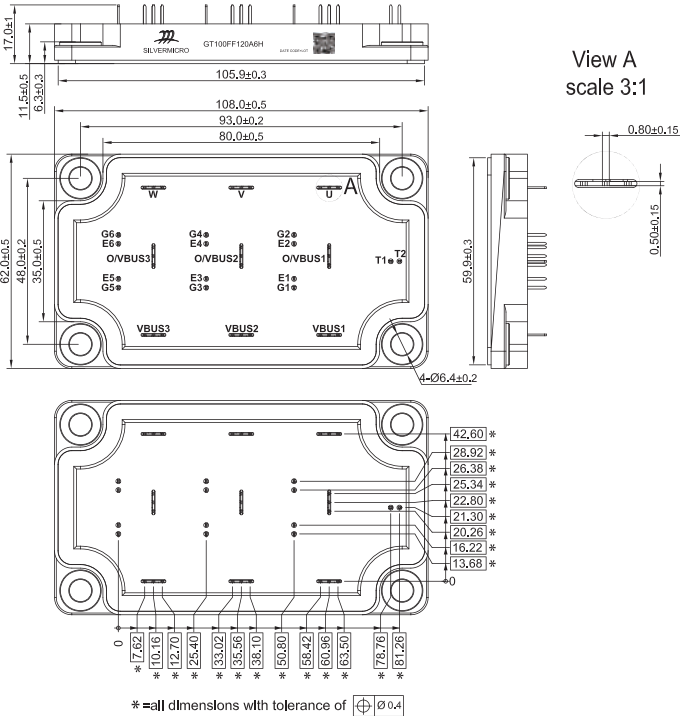

A7B-HH

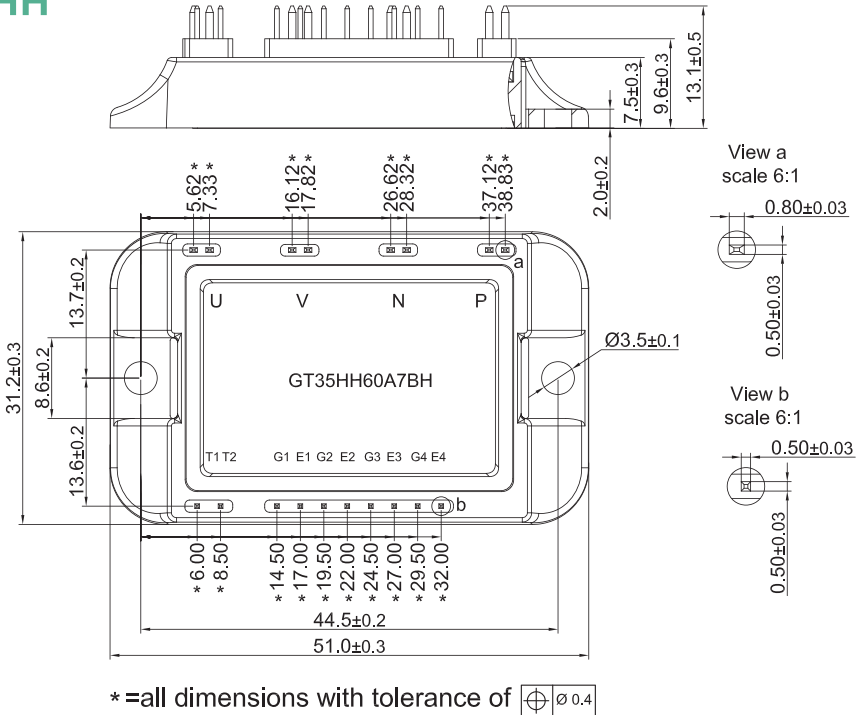

A8

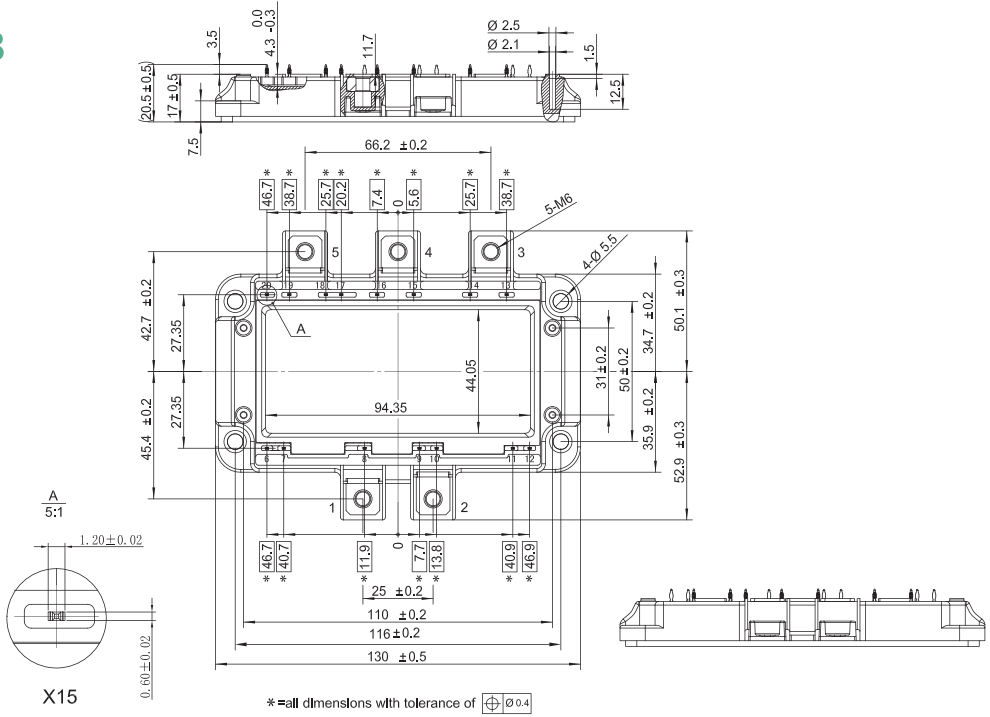

B1

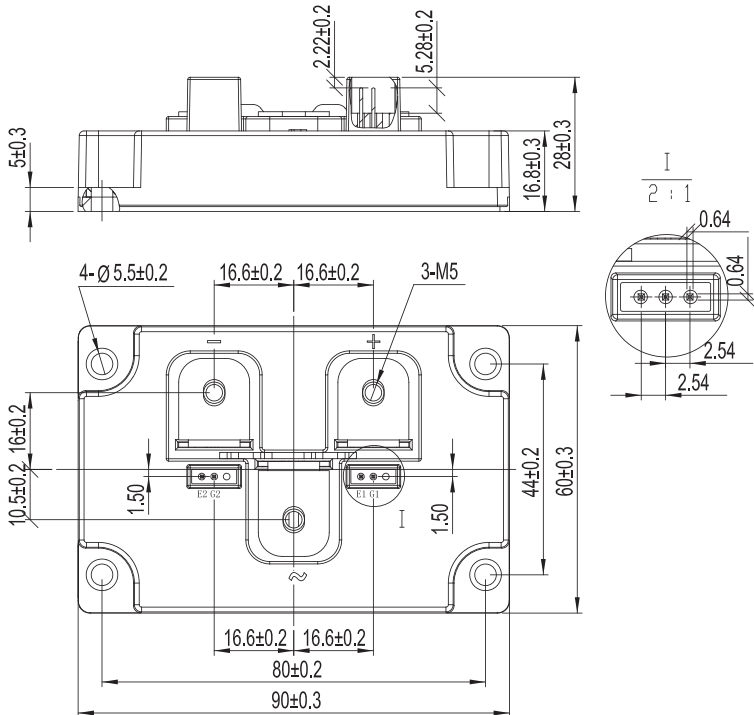

B2-TT

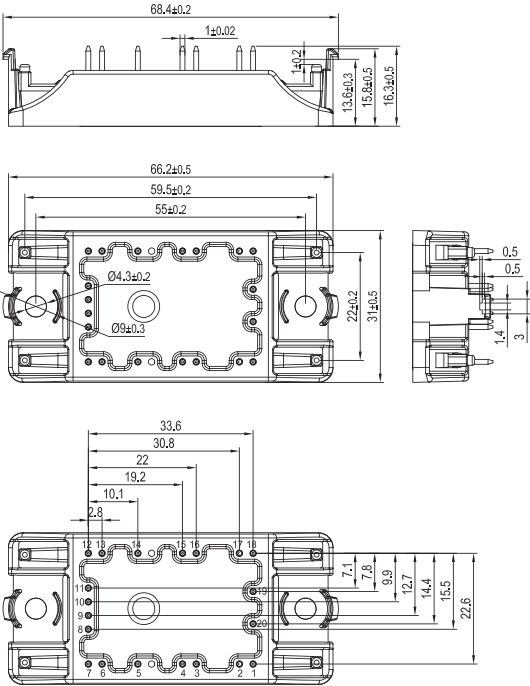

B3-FB

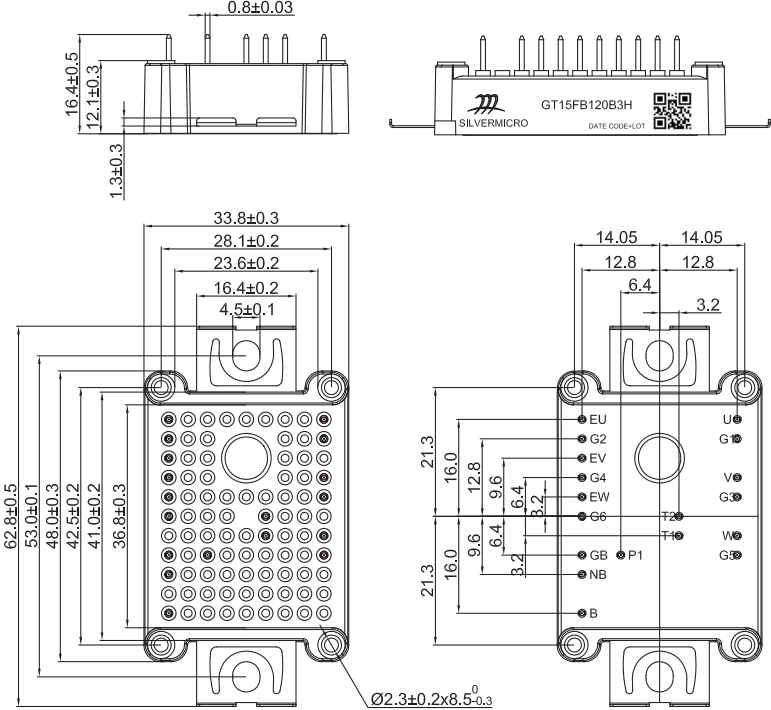

B3-FF

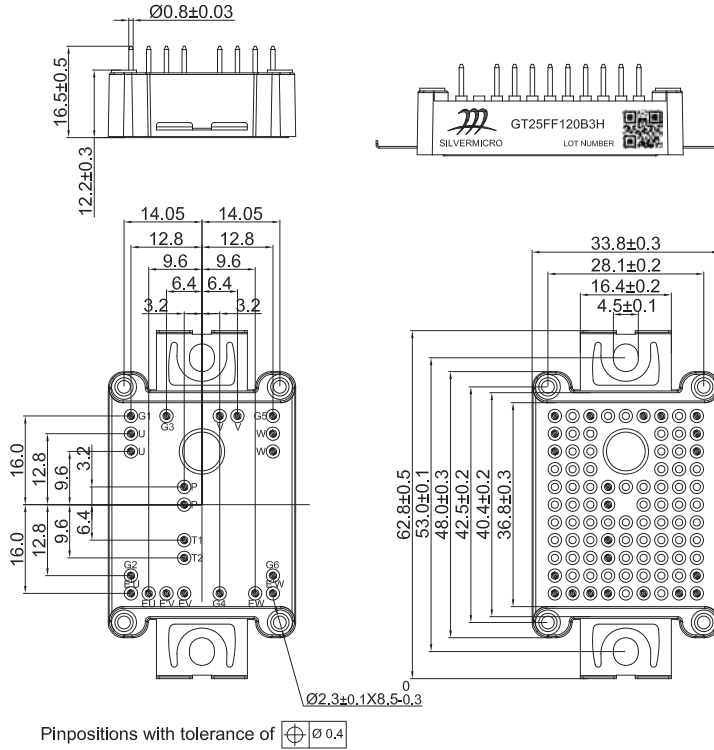

B3-HH

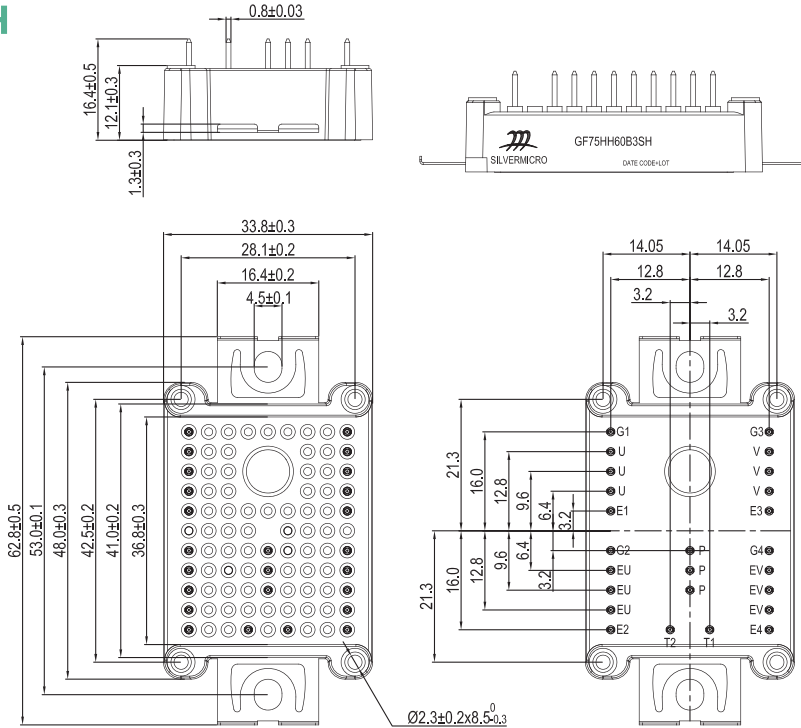

B3-PI

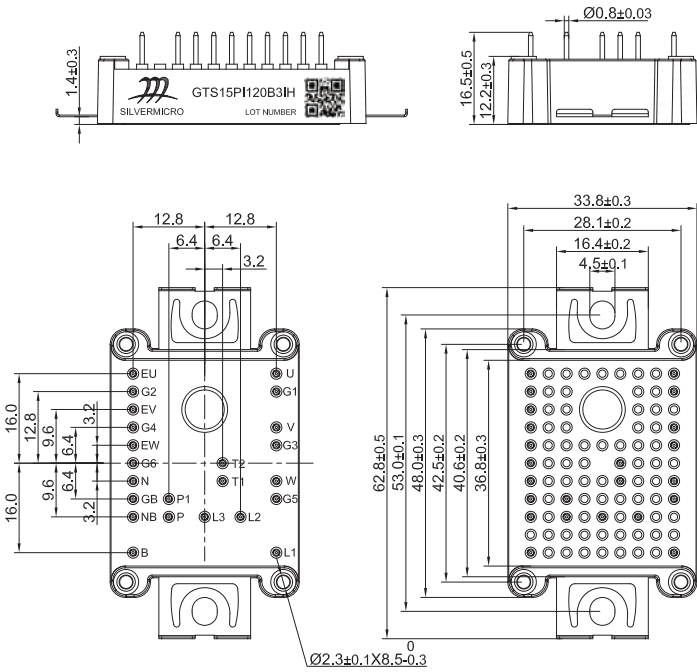

Pinpositions with tolerance of $\pm \varnothing 0.4$

B3-TL

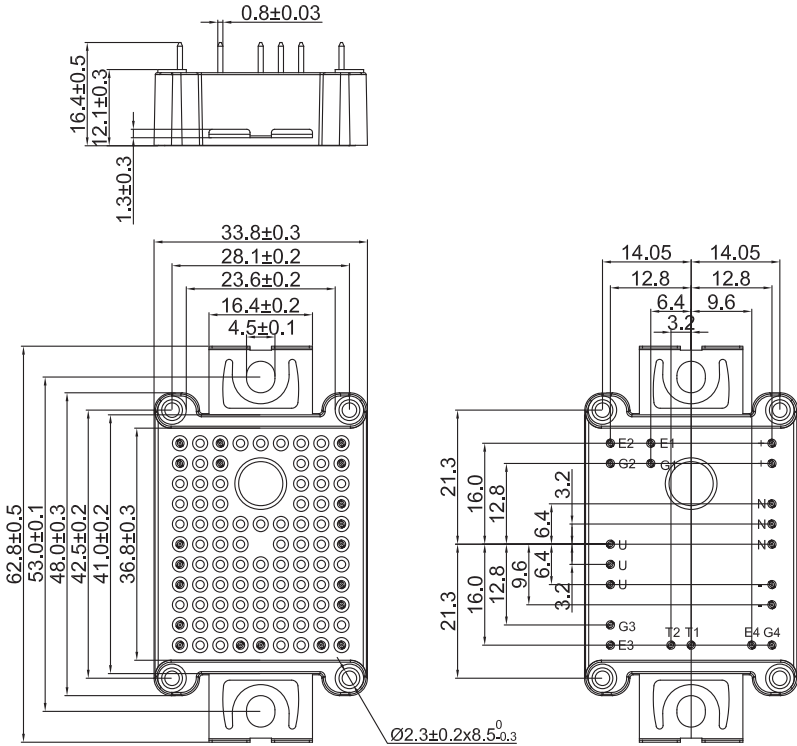

B5

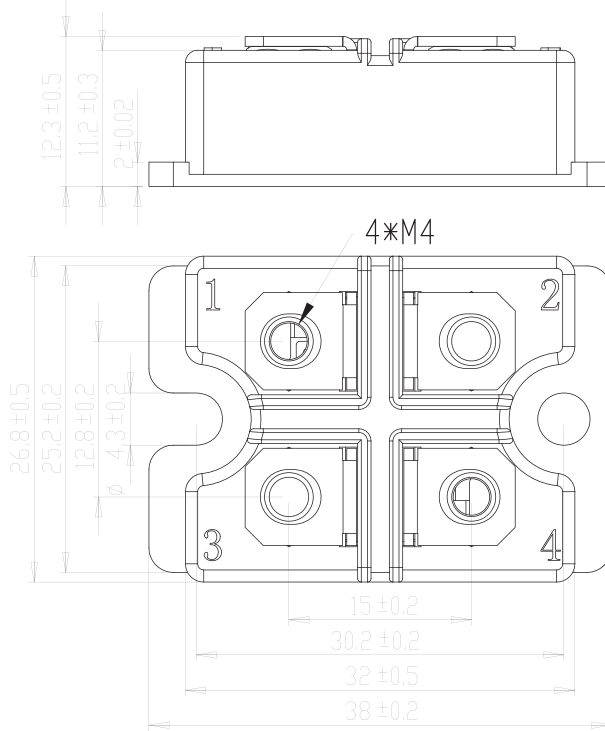

B9-FF

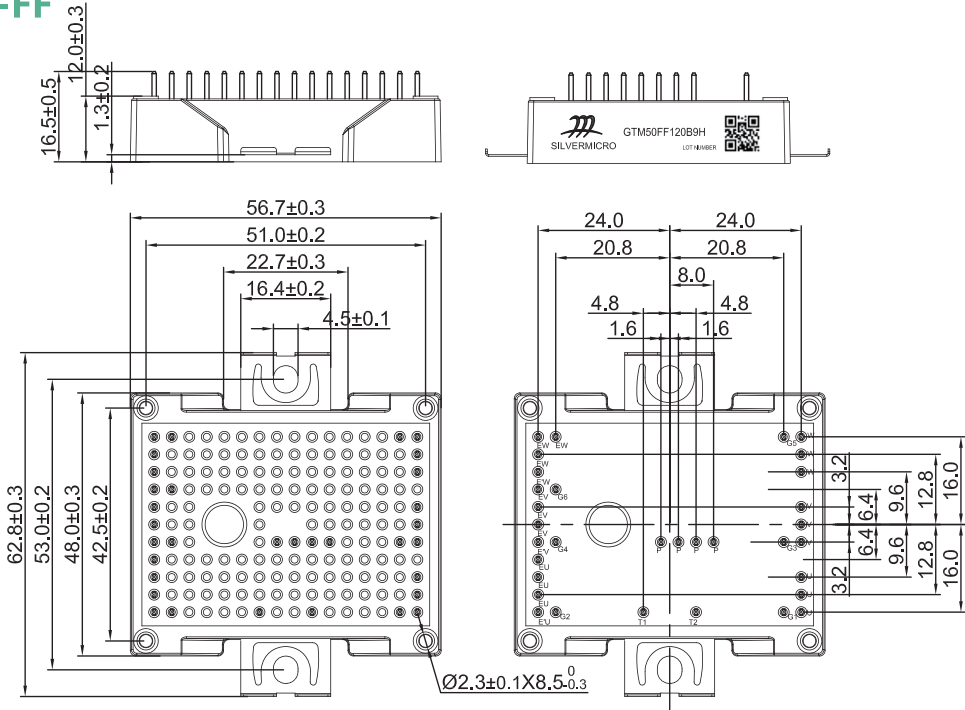

C6-FF

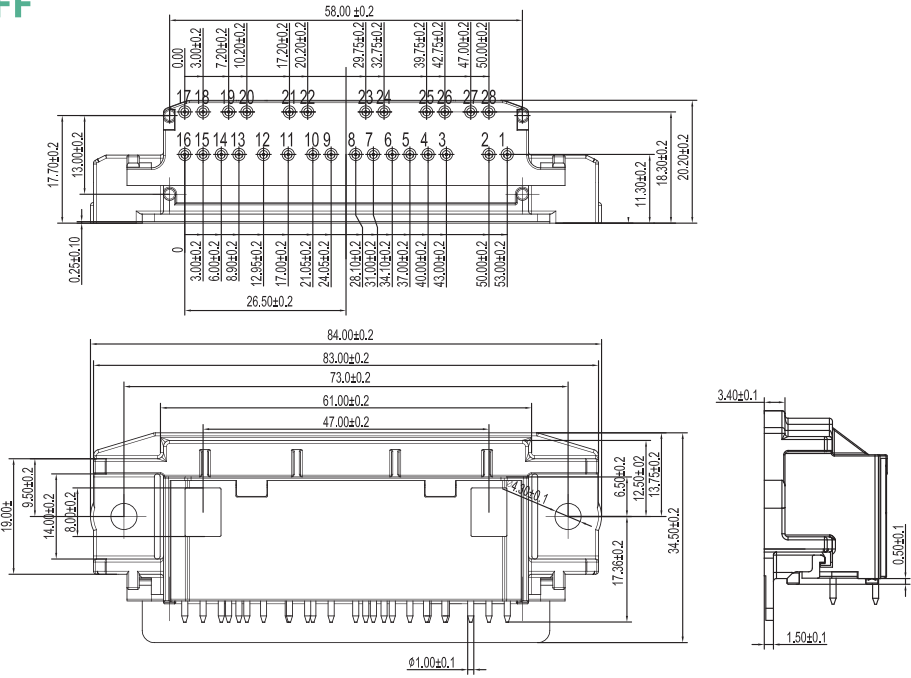

C6-PI

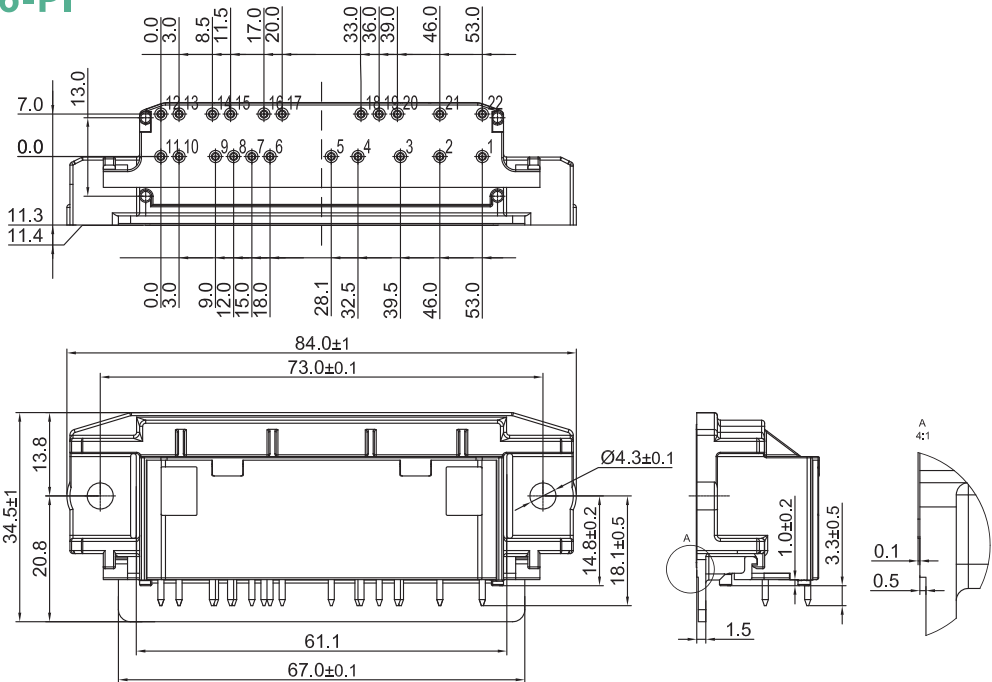

C7-FB

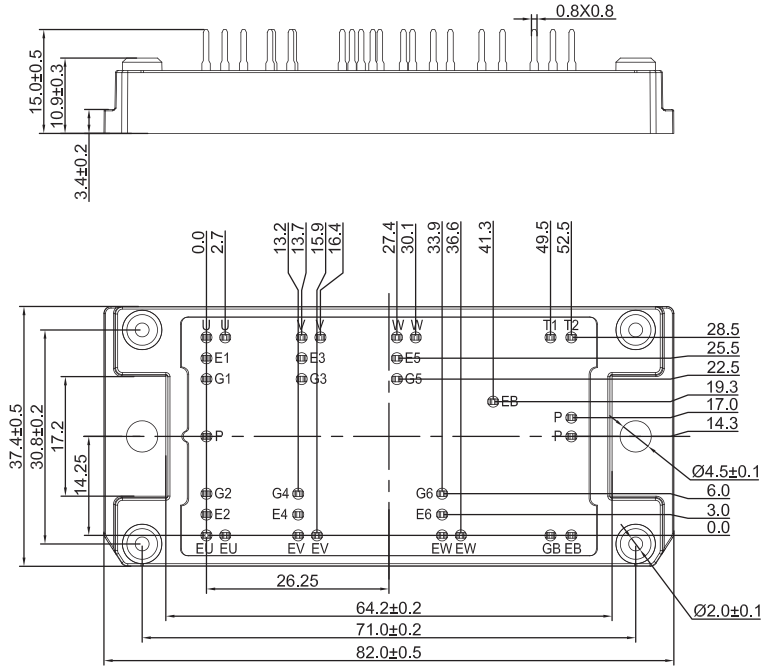

C7-FF

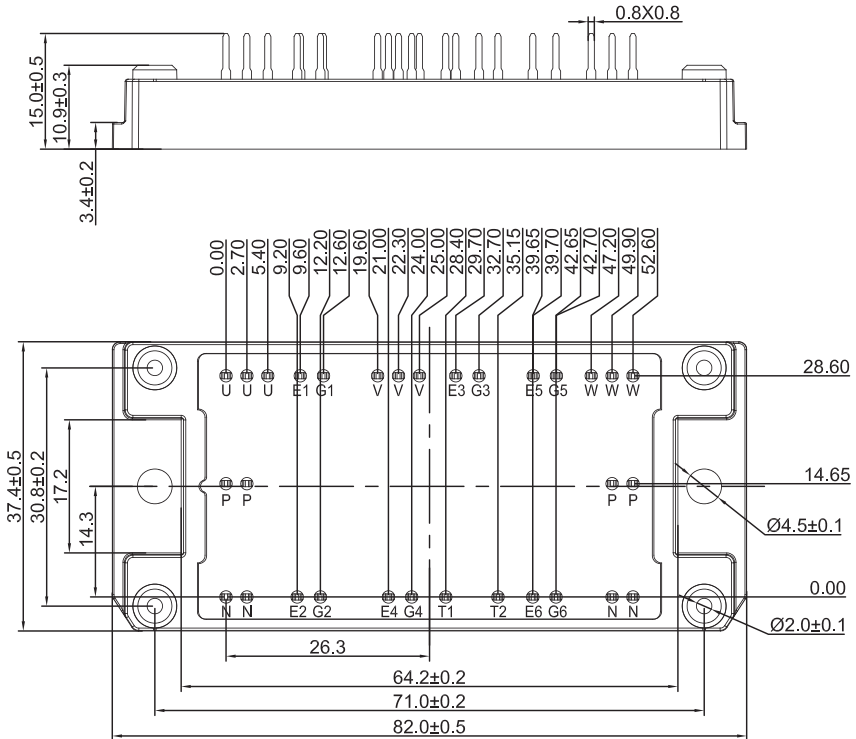

C7-HH

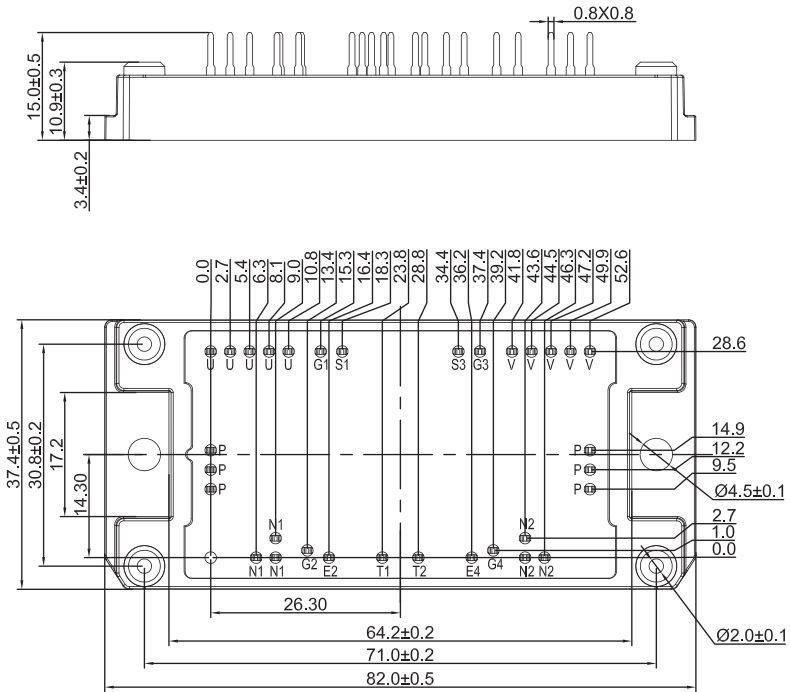

C7-PI

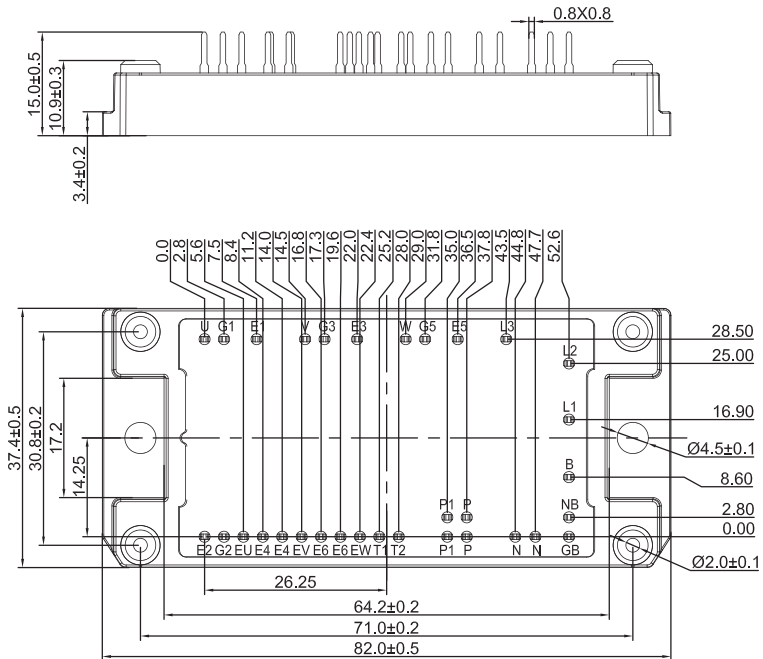

P3

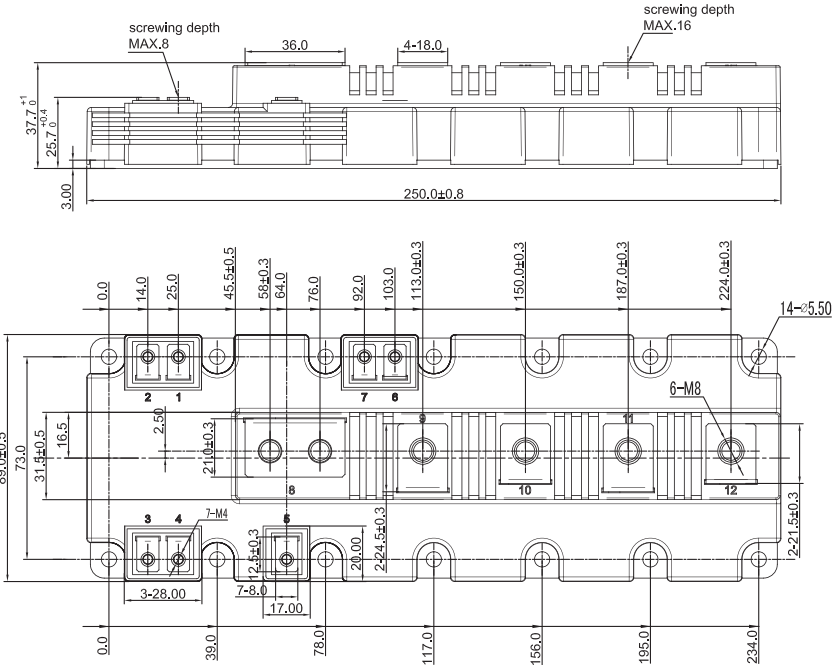

T1

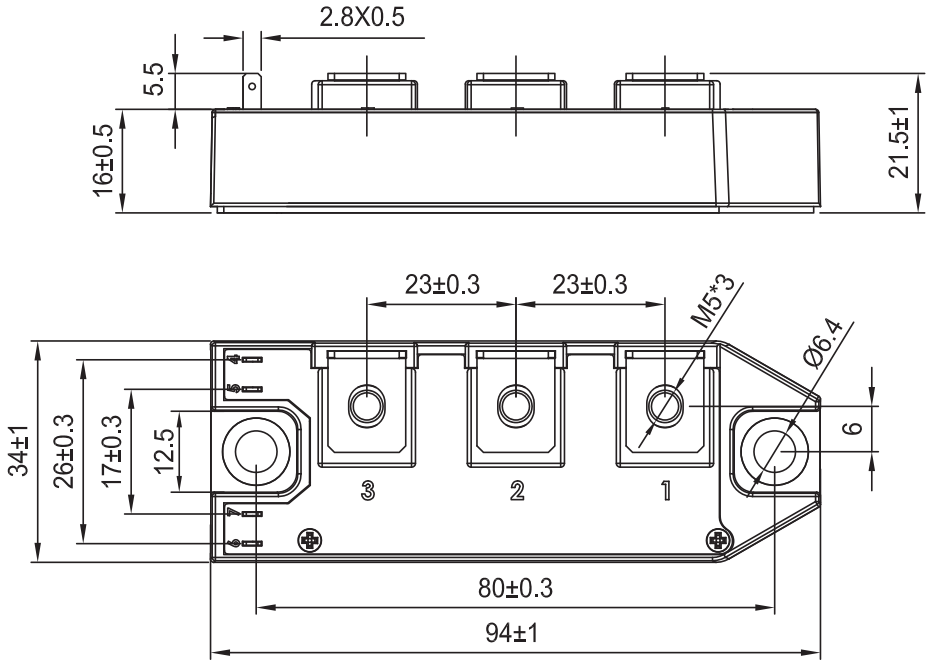

T1V

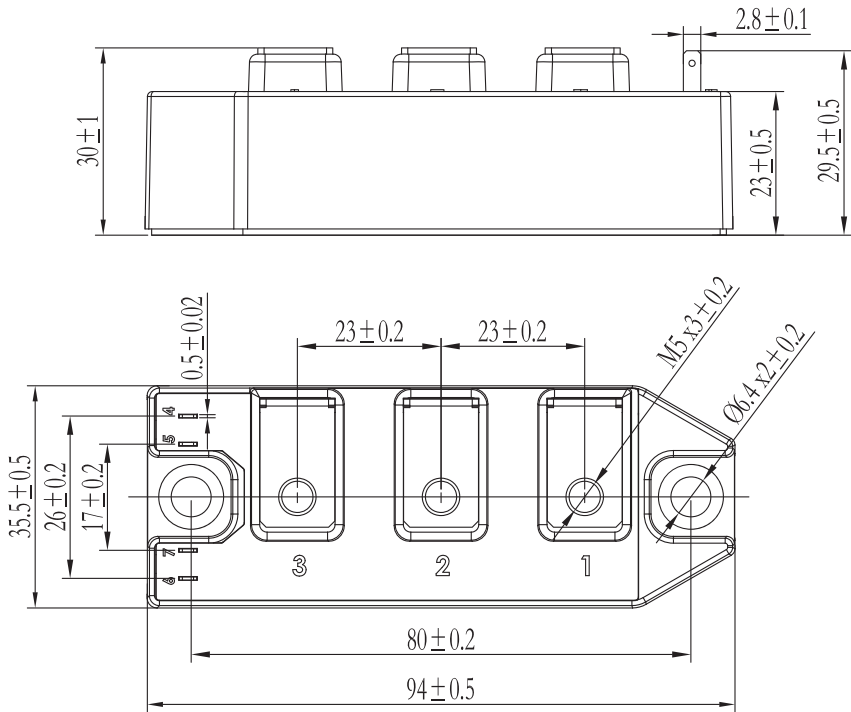

T1W

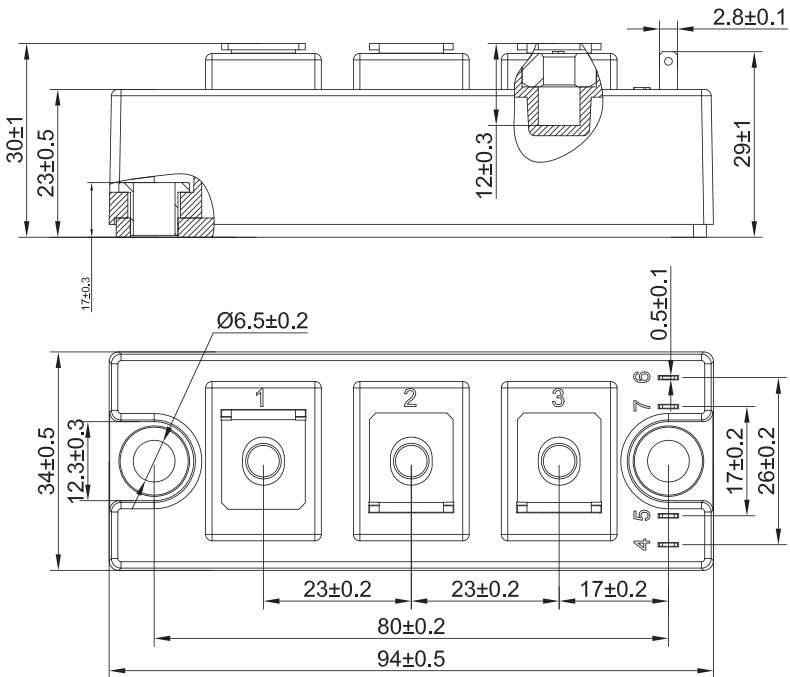

T2-CH

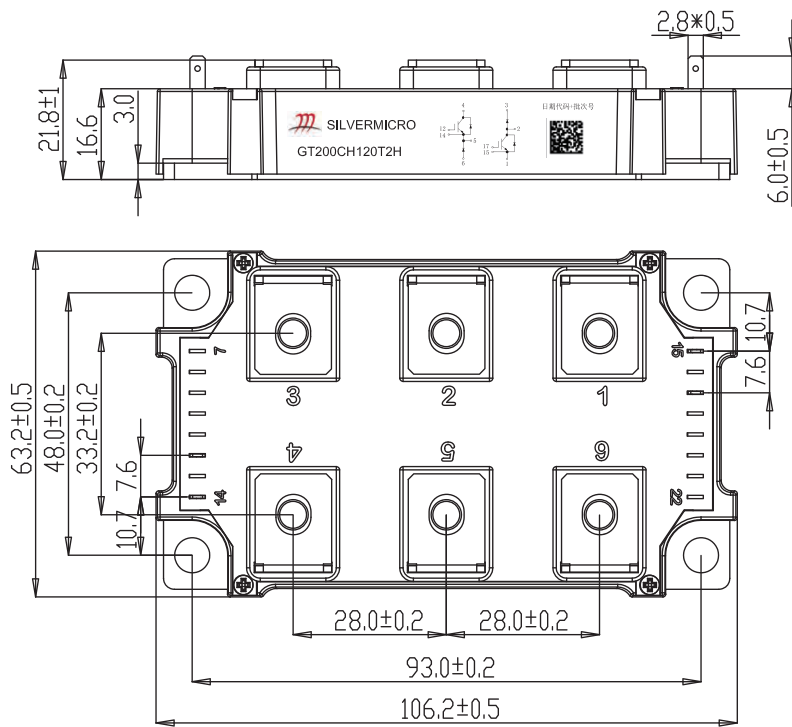

T2-HH

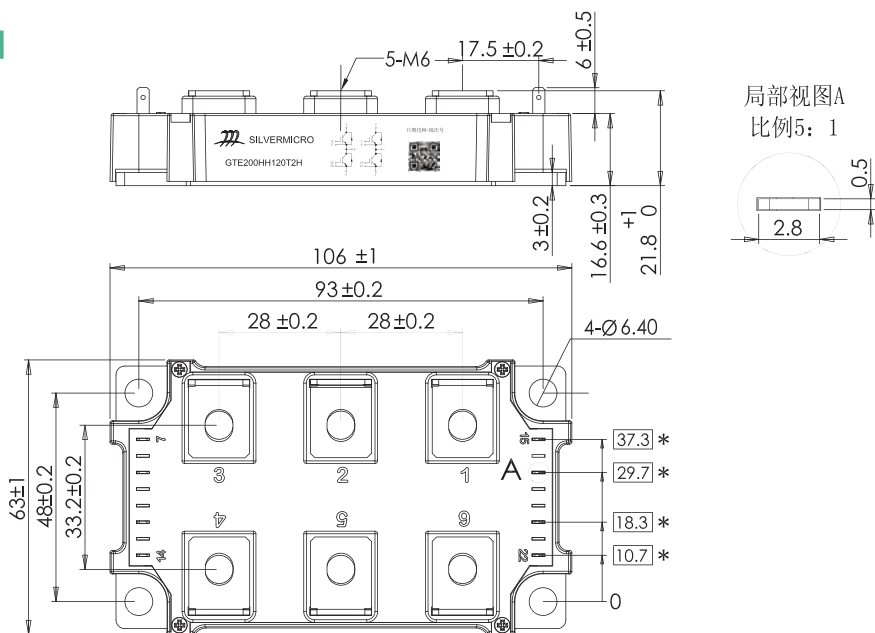

* = all dimensions with tolerance of ± 0.5

T2L

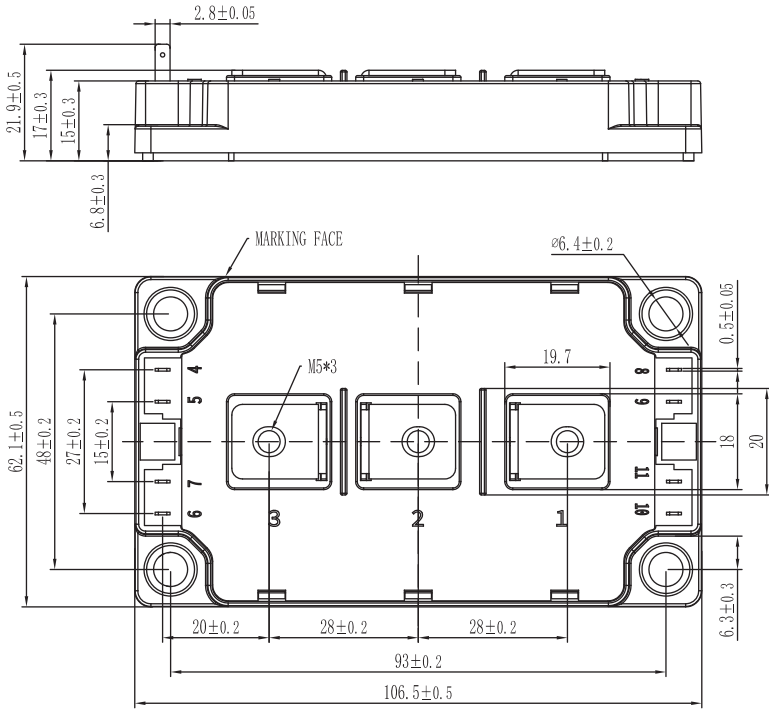

T2N

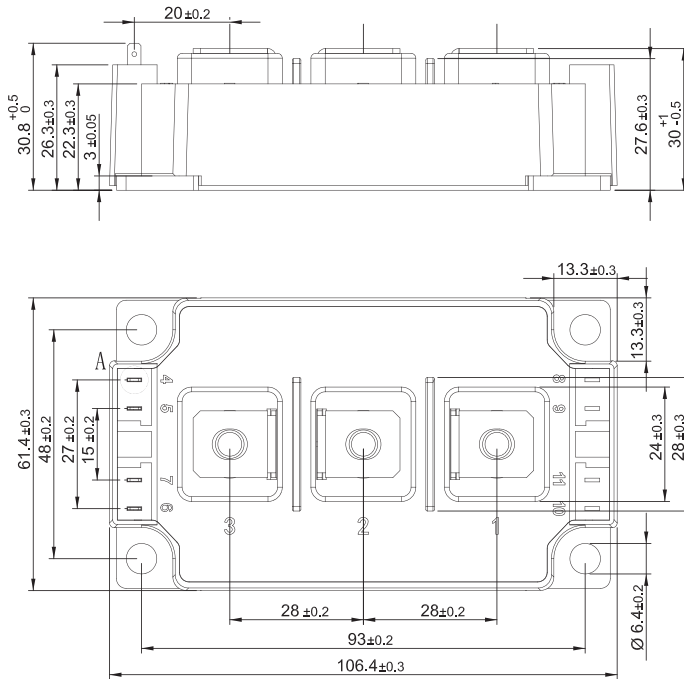

T2S

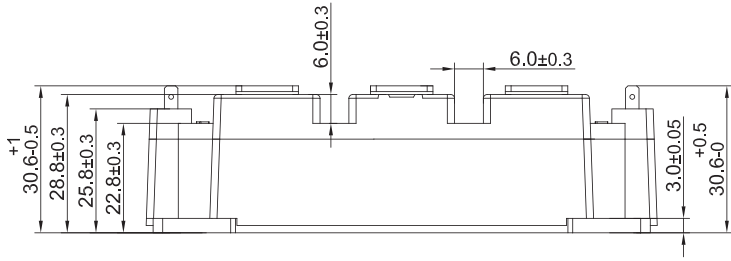

View A
scale 3:1

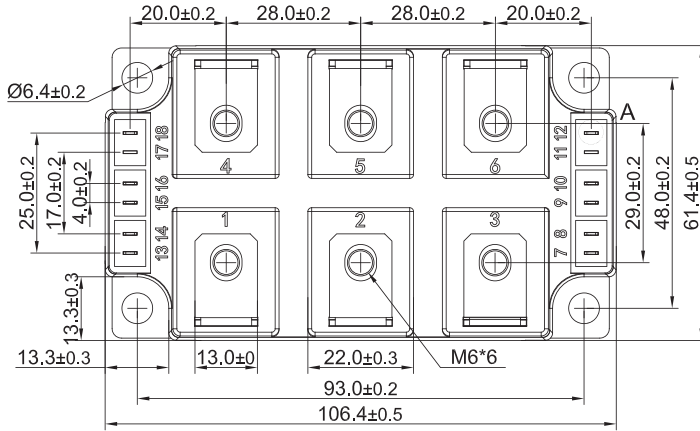
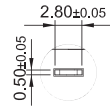

T2V

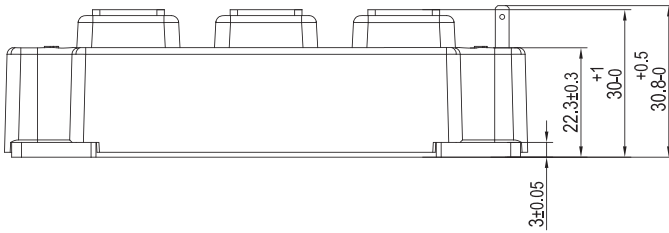

View A
scale 3:1

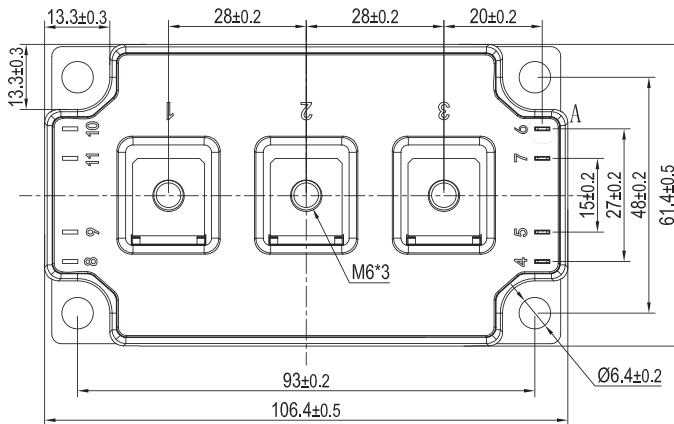
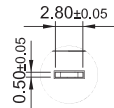

T2Z

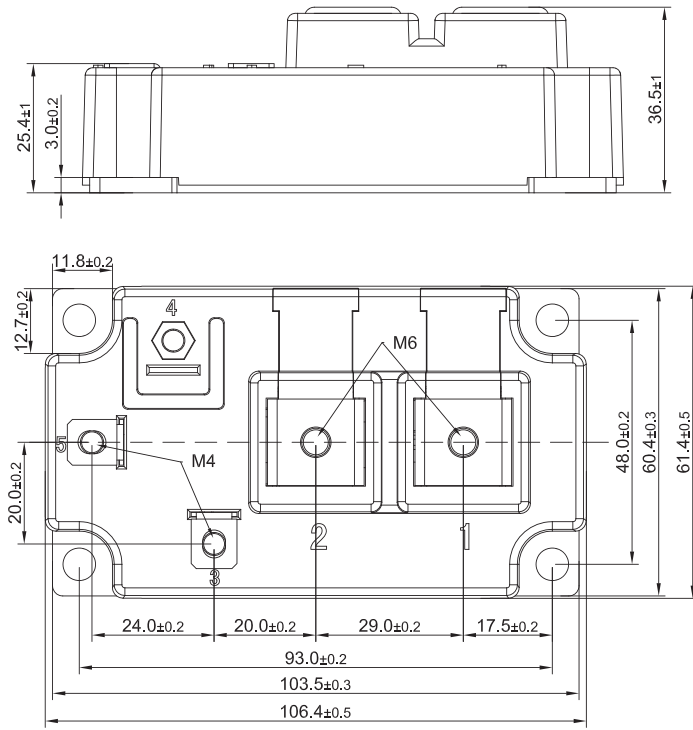

T3

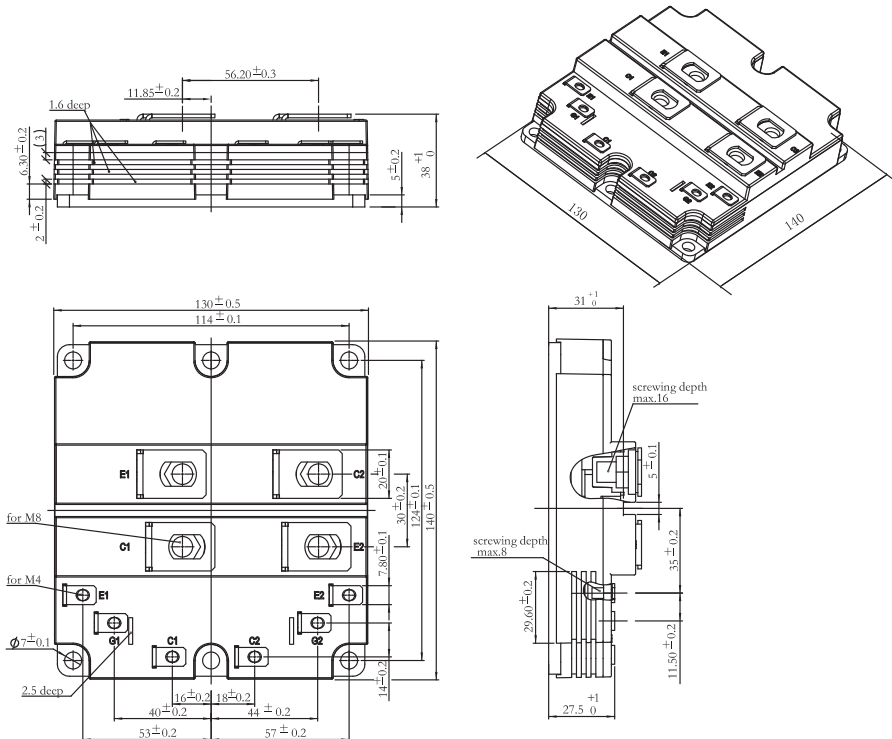

T4

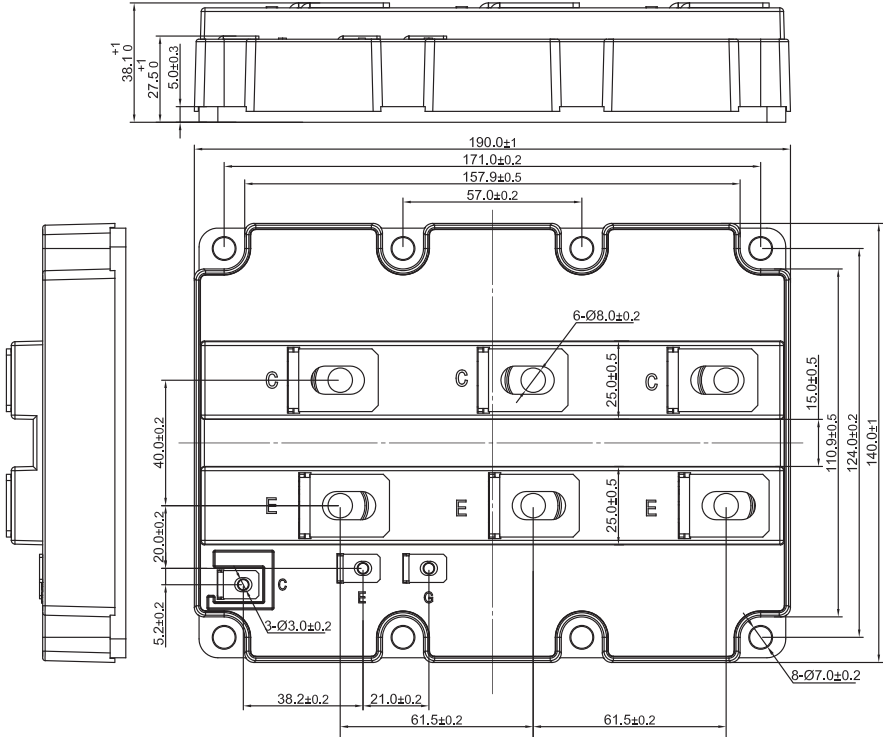

T5-CZ

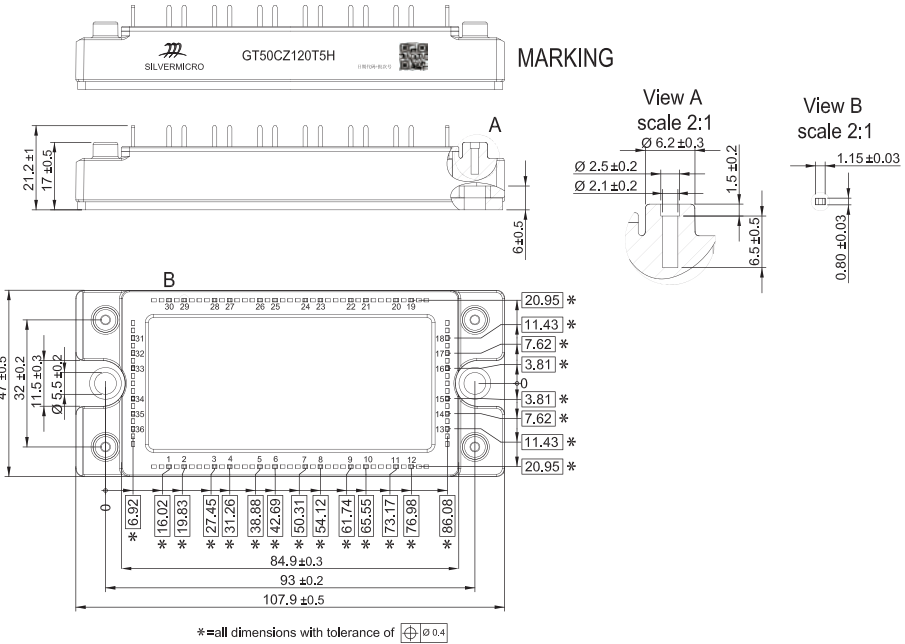

T5-FF

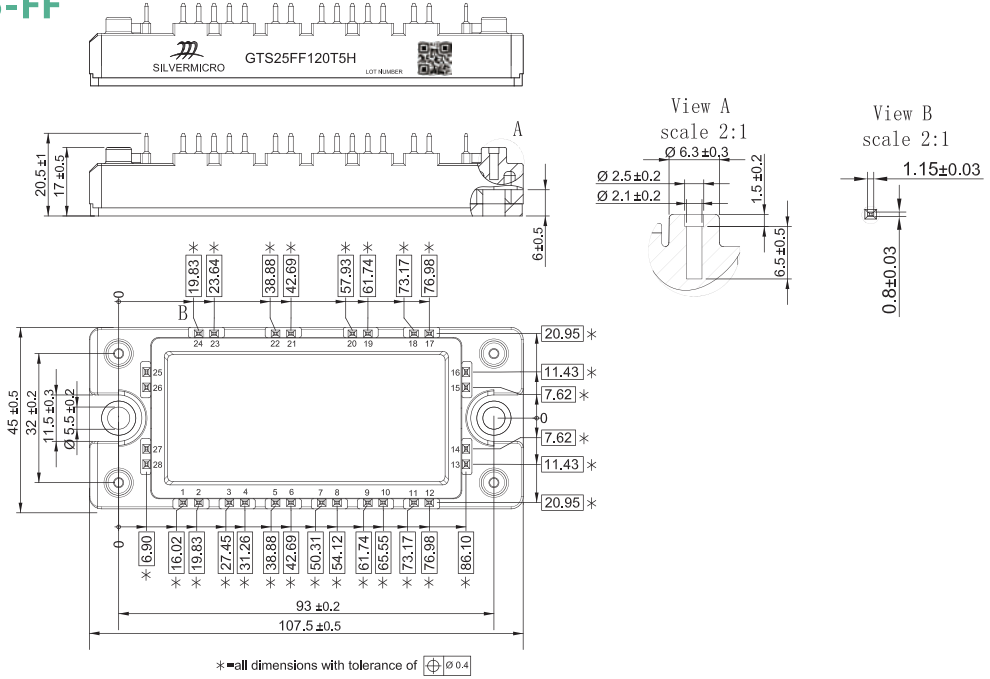

T5-HH

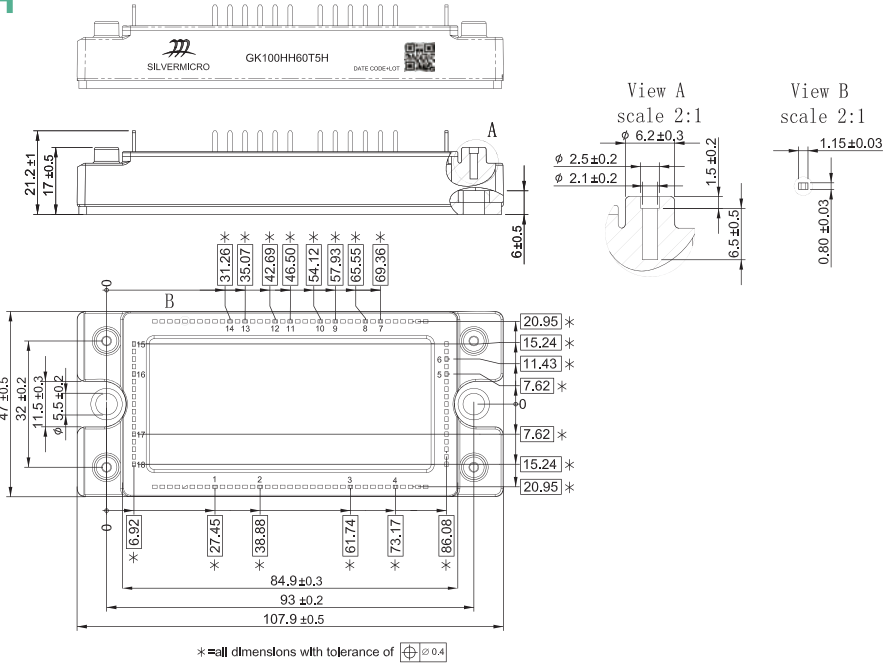

T5-PI-T4

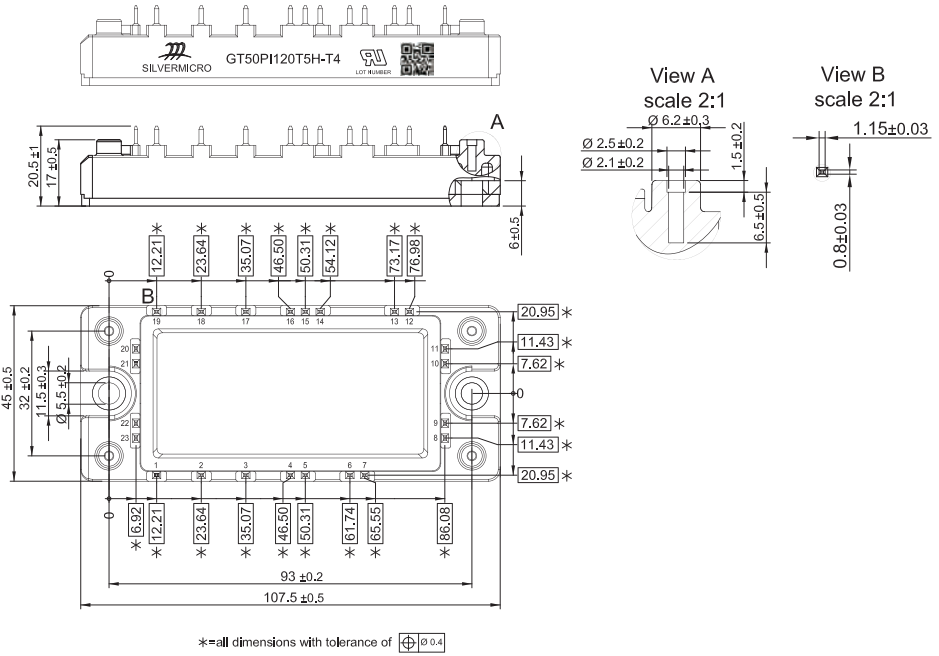

T5-PI

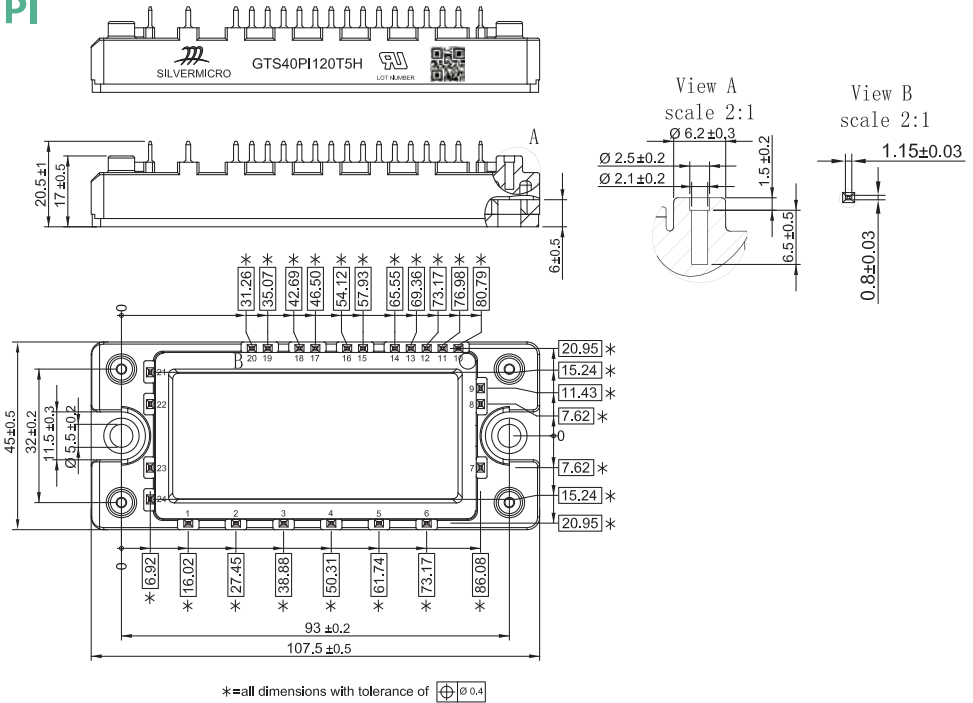

T6-CZ

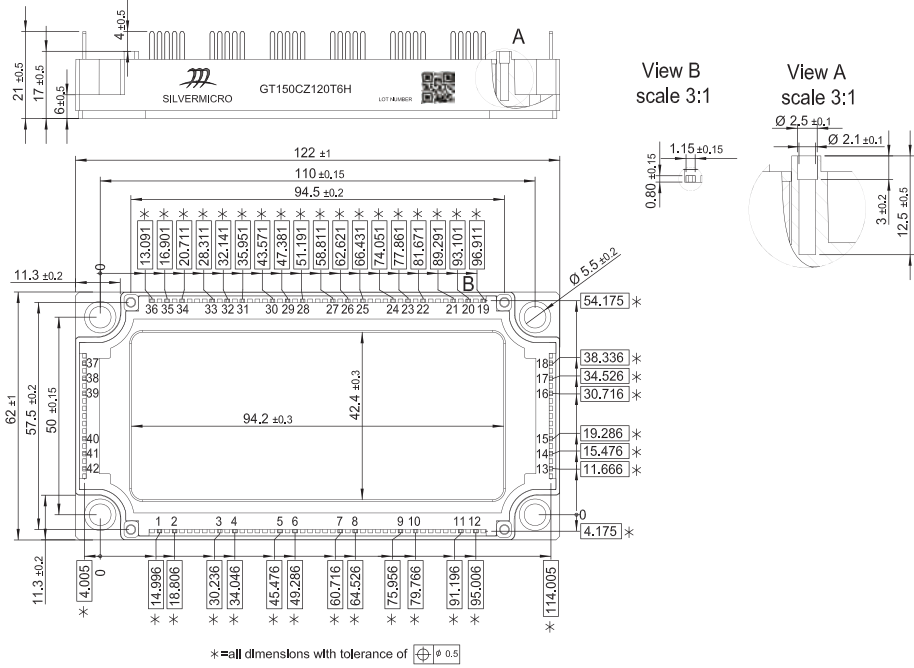

T6-FF

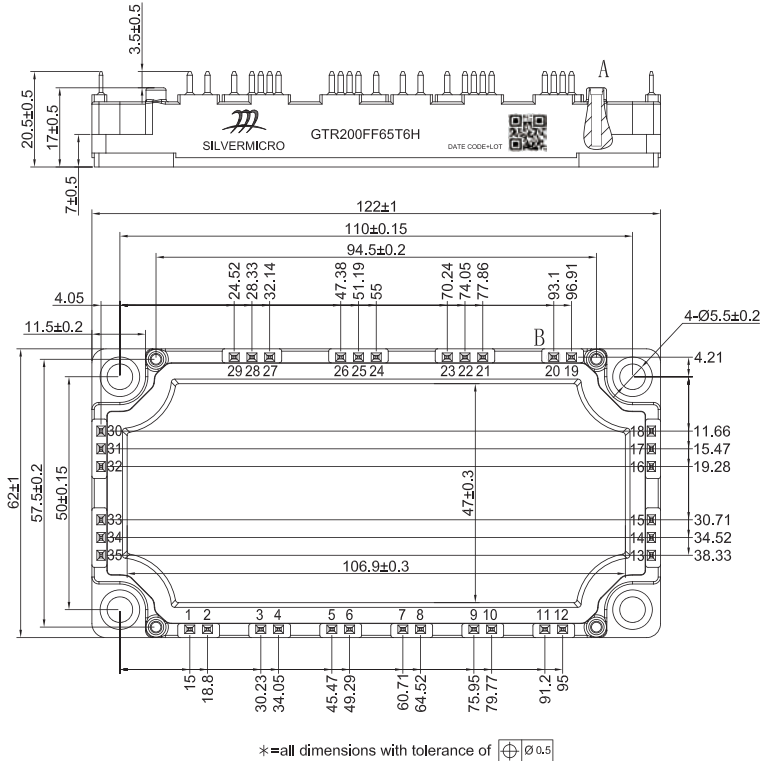

T6-HH

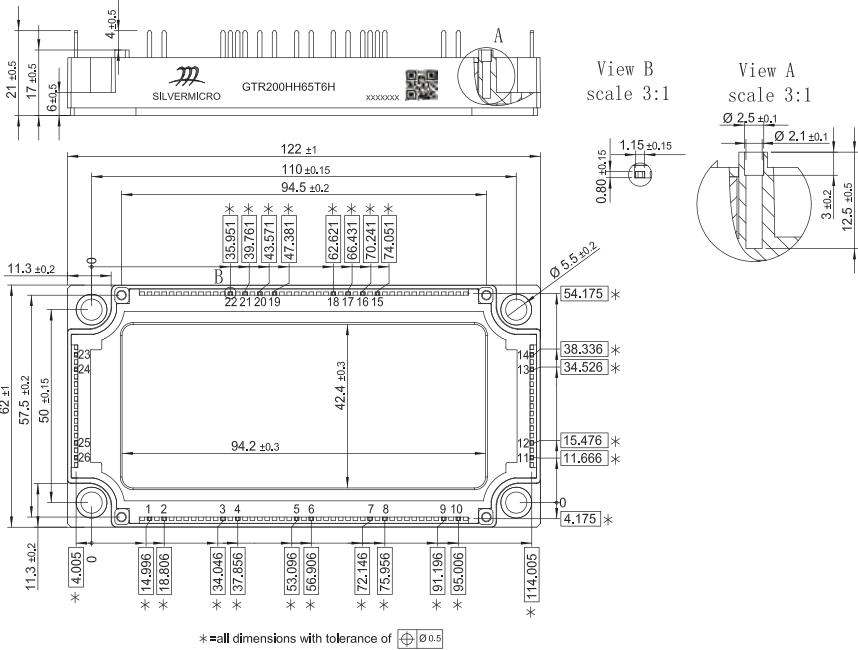

T6-PI-T4

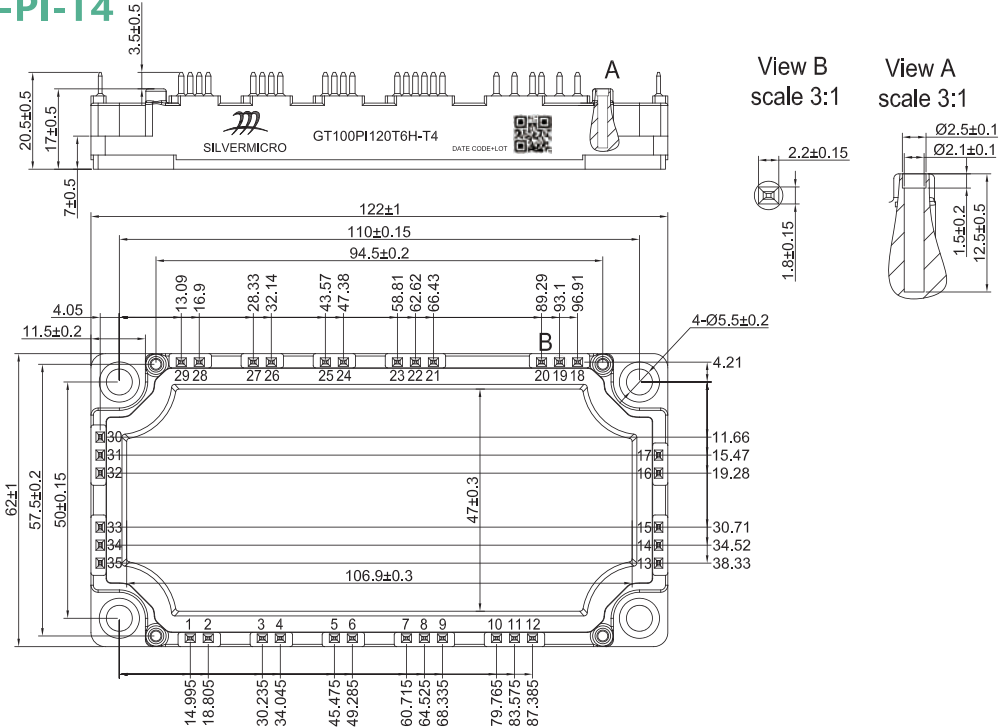

T6-PI

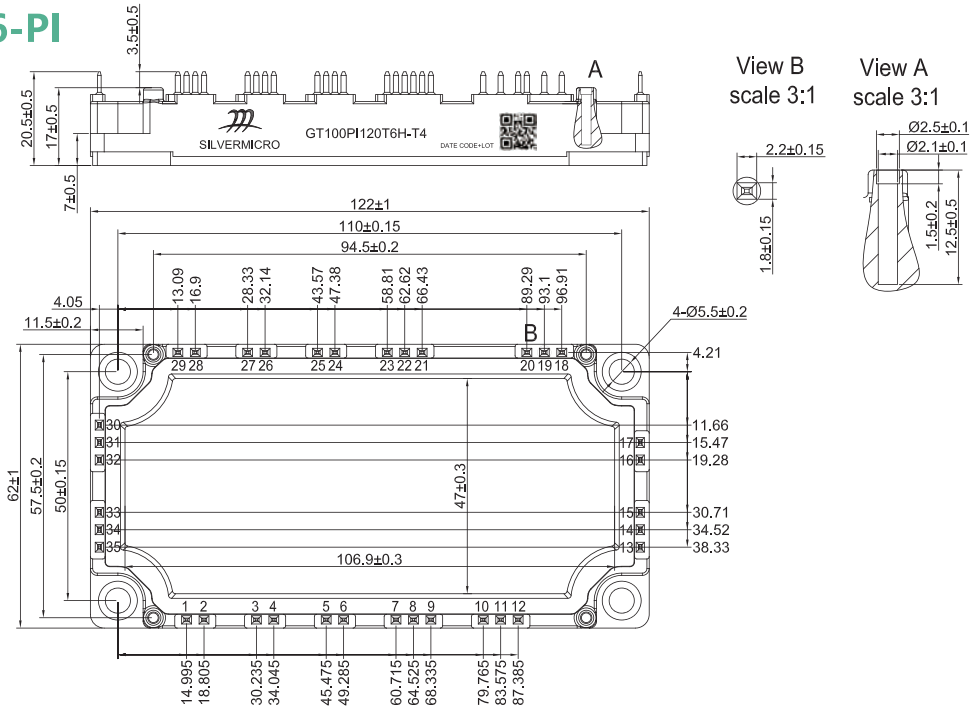

T7

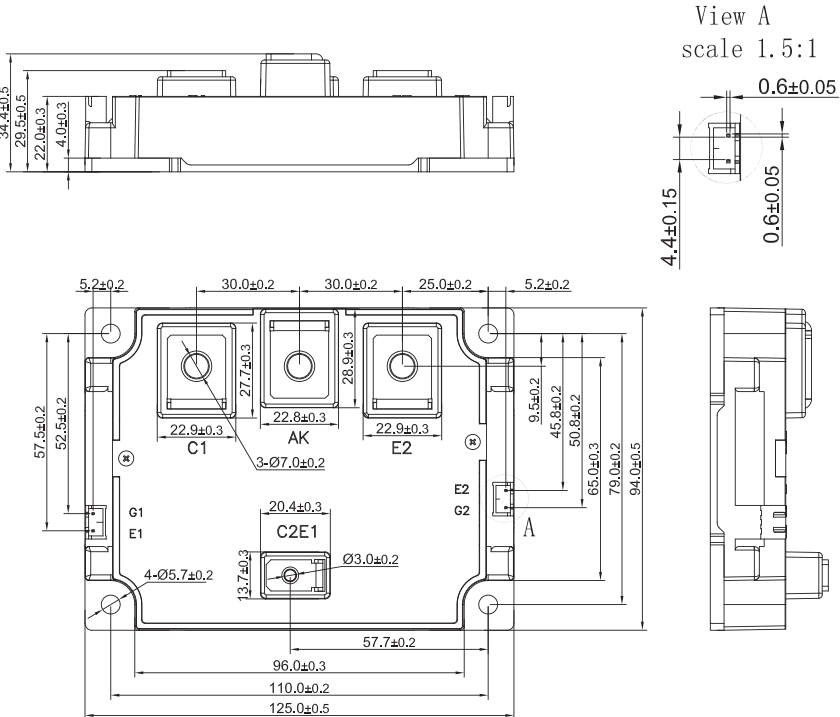

T8

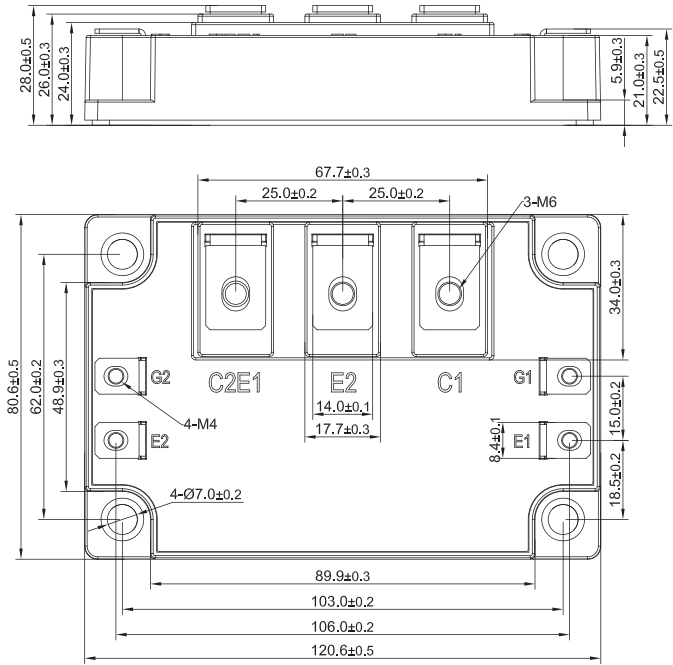

T9

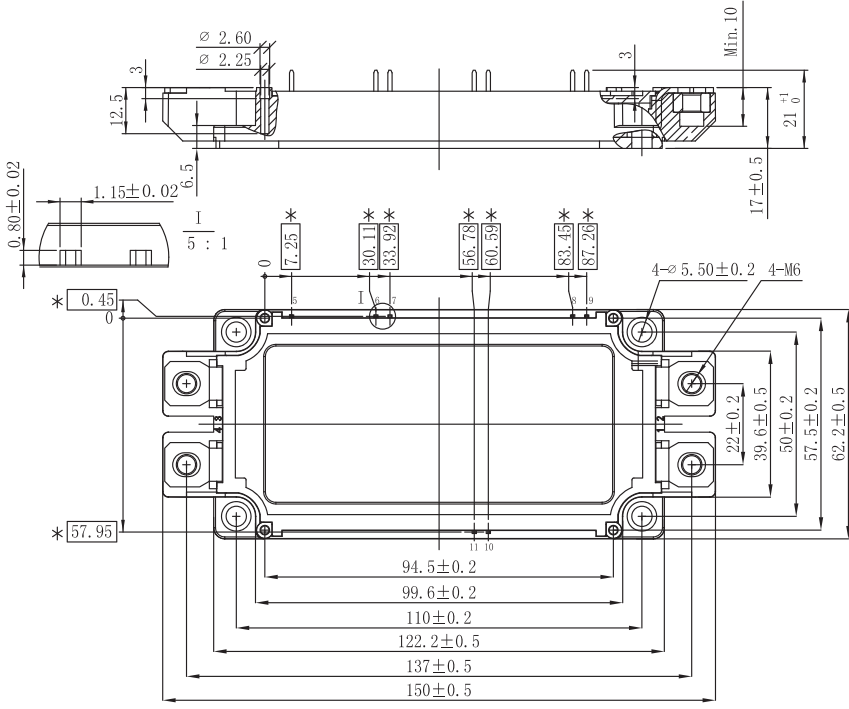

智能功率模块

Intelligent Power Modules

IPM智能功率模块

A7利用DBC基板封装技术，引线端子注塑技术，集成IC，IGBT，BSD，FWD等各部件一体化的智能功率转换模块，实现了模块集成度高，小型化。应用变频空调，冰箱，洗衣机，工业电机驱动，伺服控制，汽车电子等变频系统，为系统的小型化，高可靠性，高集成度，节能做出贡献。

特点

- 30-50A/600V产品系列
- 5-30A/1200V产品系列
- DBC基板，端子注塑技术
- HVIC键合技术

主要指标

- IGBT低导通电压（VCEon）
- 内置驱动电路
- 短路保护，控制电源欠压保护
- 3.3V正逻辑电平
- 绝缘耐压2500VRMS，1min

GT05IP120A7H	1200V/5A
GT10IP120A7H	1200V/10A
GT15IP120A7H	1200V/15A
GT20IP120A7H	1200V/20A
GT30IP120A7H	1200V/30A
GT30IP60A7H	600V/30A
GT50IP60A7H	600V/50A

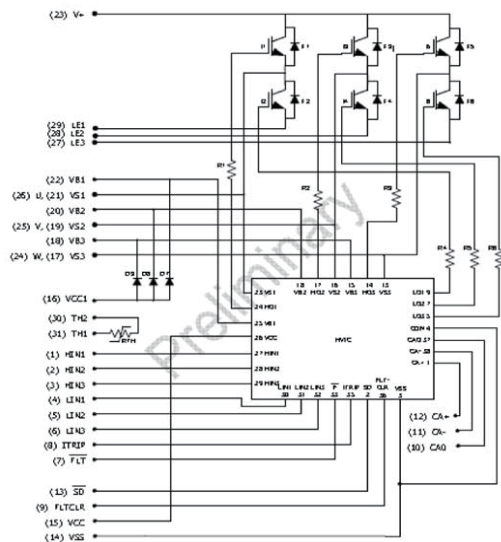
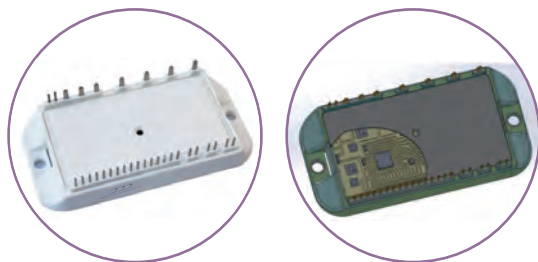

A7

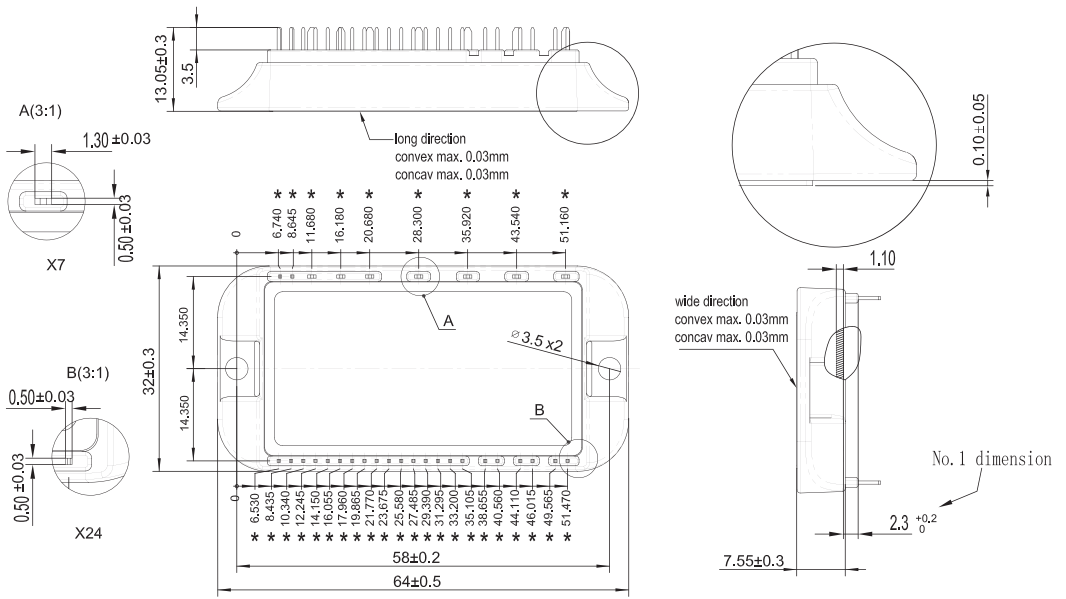

MOSFET功率模块

MOSFET Power Modules

Half Bridge (半桥MOS模块)

B1

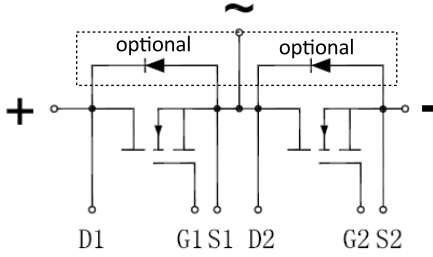

$V_{DSS}=100V$

Part Number	Voltage(V)	Current(A)	RDS(on)@10V	Package Outline	Comments
MM500HF10B1H	100	500	0.93mΩ	Page92 B1	
MM700HF10B1H	100	700	0.67mΩ	Page92 B1	
MM900HF10B1H	100	900	0.53mΩ	Page92 B1	
MM1000HF10B1H	100	1000	0.40mΩ	Page92 B1	
MM1200HF10B1H	100	1200	0.33mΩ	Page92 B1	
MM1400HF10B1H	100	1400	0.29mΩ	Page92 B1	

$V_{DSS}=150V$

Part Number	Voltage(V)	Current(A)	RDS(on)@10V	Package Outline	Comments
MM340HF15B1H	150	340	3.30mΩ	Page92 B1	with FRD
MM500HF15B1H	150	500	2.00mΩ	Page92 B1	with FRD
MM680HF15B1H	150	680	1.60mΩ	Page92 B1	with FRD
MM850HF15B1H	150	850	0.90mΩ	Page92 B1	with FRD

Half Bridge (半桥MOS模块)

B1

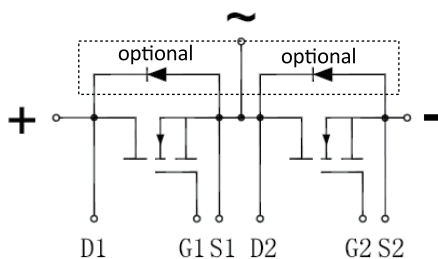

$V_{DSS}=200V$

Part Number	Voltage(V)	Current(A)	RDS(on)@10V	Package Outline	Comments
MM450HF20B1H	200	450	2.00mΩ	Page92 B1	
MM550HF20B1H	200	550	1.60mΩ	Page92 B1	
MM650HF20B1H	200	650	1.30mΩ	Page92 B1	

Half Bridge (半桥MOS模块)

T2N

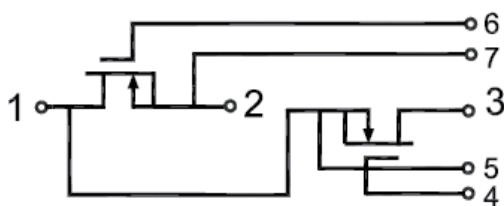

$V_{DSS}=100V$

Part Number	Voltage(V)	Current(A)	RDS(on)@10V	Package Outline	Comments
MM500HF10T2NH	100	500	0.93mΩ	Page92 T2N	
MM700HF10T2NH	100	700	0.67mΩ	Page92 T2N	
MM900HF10T2NH	100	900	0.53mΩ	Page92 T2N	
MM1000HF10T2NH	100	1000	0.40mΩ	Page92 T2N	
MM1200HF10T2NH	100	1200	0.33mΩ	Page92 T2N	
MM1400HF10T2NH	100	1400	0.29mΩ	Page92 T2N	

Half Bridge (半桥MOS模块)

T2N

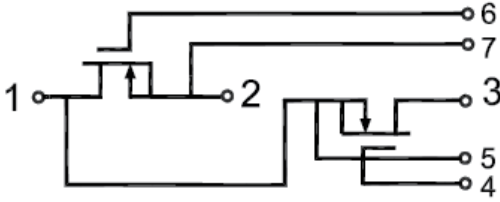

$V_{DSS}=150V$

Part Number	Voltage(V)	Current(A)	RDS(on)@10V	Package Outline	Comments
MM340HF15T2NH	150	340	3.30m Ω	Page92 T2N	with FRD
MM500HF15T2NH	150	500	2.00m Ω	Page92 T2N	with FRD
MM680HF15T2NH	150	680	1.60m Ω	Page92 T2N	with FRD
MM850HF15T2NH	150	850	0.90m Ω	Page92 T2N	with FRD

$V_{DSS}=200V$

Part Number	Voltage(V)	Current(A)	RDS(on)@10V	Package Outline	Comments
MM450HF20T2NH	200	450	2.00m Ω	Page92 T2N	with FRD
MM550HF20T2NH	200	550	1.60m Ω	Page92 T2N	with FRD
MM650HF20T2NH	200	650	1.30m Ω	Page92 T2N	with FRD

汽车模块

Automotive Modules

Full Bridge (全桥IGBT模块)

A8

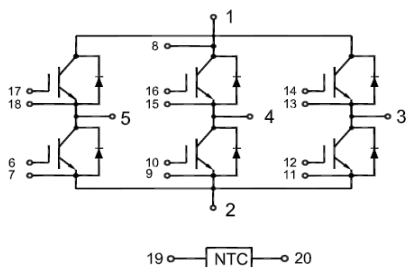

$V_{CES}=650V$

Part Number	Voltage(V)	Current(A)	Technology	Package Outline	Comments
沟槽型T系列-Trench T Series					
GT200FF65A8S	650	200	Trench FS	Page103 A8	
GT300FF65A8S	650	300	Trench FS	Page103 A8	
GT400FF65A8S	650	400	Trench FS	Page103 A8	

$V_{DSS}=1200V$

Part Number	Voltage(V)	Current(A)	Technology	Package Outline	Comments
沟槽型T系列-Trench T Series					
GT100FF120A8S	1200	100	Trench FS	Page103 A8	
GT150FF120A8S	1200	150	Trench FS	Page103 A8	
GT200FF120A8S	1200	200	Trench FS	Page103 A8	

Full Bridge (全桥IGBT模块)

B3

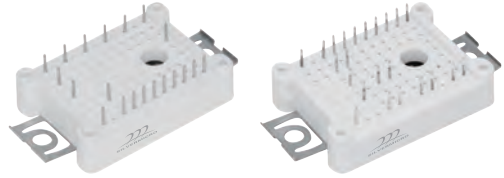
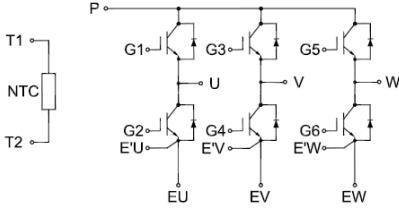

$V_{CES}=1200V$

Part Number	Voltage(V)	Current(A)	Technology	Package Outline	Comments
沟槽型T系列-Trench T Series					
GT25FF120B3S	1200	25	Trench FS	Page104 B3P-FF	press-fit pins
GT35FF120B3S	1200	35	Trench FS	Page104 B3P-FF	press-fit pins
沟槽型T系列-Trench T Series					
GTS25FF120B3S	1200	25	Trench FS	Page104 B3P-FF	press-fit pins
GTS40FF120B3S	1200	40	Trench FS	Page104 B3P-FF	press-fit pins

Full Bridge (全桥IGBT模块)

B8

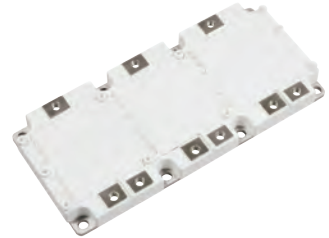
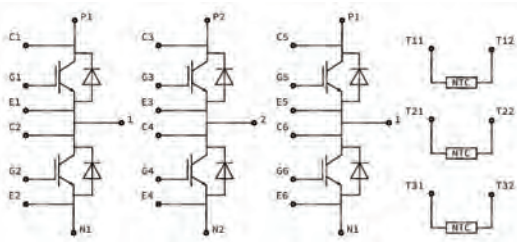

$V_{CES}=650V$

Part Number	Voltage(V)	Current(A)	Technology	Package Outline	Comments
沟槽型T系列-Trench T Series					
GT600FF65B8S	650	600	Trench FS	Page104 B8	
GT800FF65B8S	650	800	Trench FS	Page104 B8	

Full Bridge (全桥IGBT模块)

B8

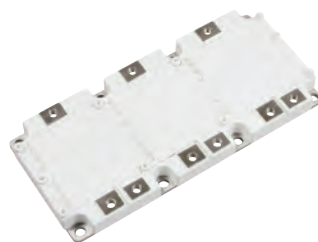
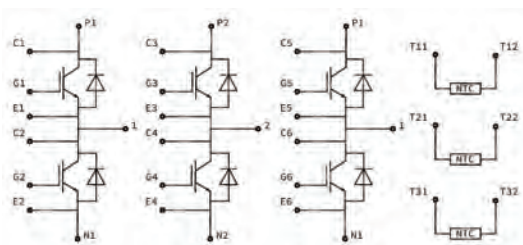

V_{CES}=1200V

Part Number	Voltage(V)	Current(A)	Technology	Package Outline	Comments
沟槽型T系列-Trench T Series					
GT400FF120B8S	1200	400	Trench FS	Page104 B8	
GT600FF120B8S	1200	600	Trench FS	Page104 B8	

B9

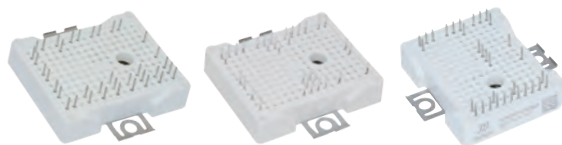
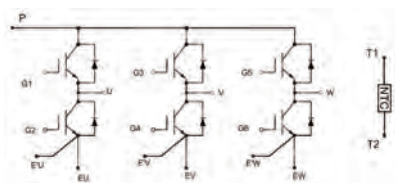

V_{CES}=1200V

Part Number	Voltage(V)	Current(A)	Technology	Package Outline	Comments
标准型K系列-Standard K Series					
GT50FF120B9S	1200	50	Trench FS	Page105 B9P-FF	press-fit pins
GT75FF120B9S	1200	75	Trench FS	Page105 B9P-FF	press-fit pins

Full Bridge (全桥IGBT模块)

C8

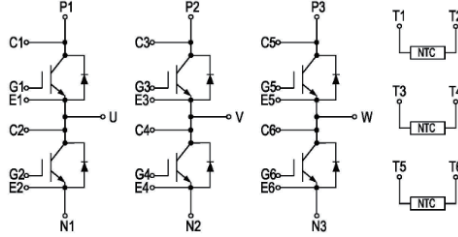

V_{CES}=750V

Part Number	Voltage(V)	Current(A)	Technology	Package Outline	Comments
沟槽型T系列-Trench T Series					
GT400FF75C8S	750	400	Trench FS	Page105/106 C8-S04/S17 Page106/107 C8-S05/S06	
GT600FF75C8S	750	600	Trench FS	Page105/106 C8-S04/S17 Page106/107 C8-S05/S06	
GT820FF75C8S	750	820	Trench FS	Page105/106 C8-S04/S17 Page106/107 C8-S05/S06	

V_{CES}=1200V

Part Number	Voltage(V)	Current(A)	Technology	Package Outline	Comments
沟槽型T系列-Trench T Series					
GT300FF120C8S	1200	300	Trench FS	Page105/106 C8-S04/S17 Page106/107 C8-S05/S06	
GT400FF120C8S	1200	400	Trench FS	Page105/106 C8-S04/S17 Page106/107 C8-S05/S06	

Full Bridge (全桥IGBT模块)

C8N

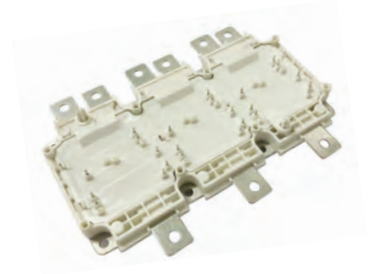
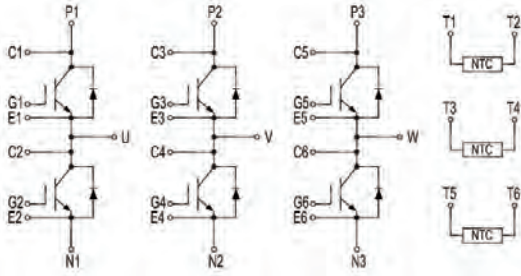

$V_{CES}=750V$

Part Number	Voltage(V)	Current(A)	Technology	Package Outline	Comments
沟槽型T系列-Trench T Series					
GT200FF75C8NS	750	200	Trench FS	Page107/108 C8N-S04/S17	
GT300FF75C8NS	750	300	Trench FS	Page107/108 C8N-S04/S17	
GT400FF75C8NS	750	400	Trench FS	Page107/108 C8N-S04/S17	

$V_{CES}=1200V$

Part Number	Voltage(V)	Current(A)	Technology	Package Outline	Comments
沟槽型T系列-Trench T Series					
GT100FF120C8NS	1200	100	Trench FS	Page107/108 C8N-S04/S17	
GT150FF120C8NS	1200	150	Trench FS	Page107/108 C8N-S04/S17	
GT200FF120C8NS	1200	200	Trench FS	Page107/108 C8N-S04/S17	
GT300FF120C8NS	1200	300	Trench FS	Page107/108 C8N-S04/S17	

Half Bridge (半桥IGBT模块)

T9

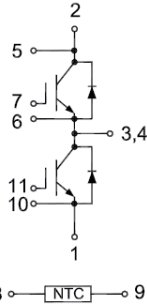

$V_{CES}=650V$

8 — NTC — 9

Part Number	Voltage(V)	Current(A)	Technology	Package Outline	Comments
沟槽型T系列-Trench T Series					
GT300HF65T9S	650	300	Trench FS	Page109 T9	
GT450HF65T9S	650	450	Trench FS	Page109 T9	
GT600HF65T9S	650	600	Trench FS	Page109 T9	

$V_{CES}=1200V$

Part Number	Voltage(V)	Current(A)	Technology	Package Outline	Comments
沟槽型T系列-Trench T Series					
GT225HF120T9S	1200	225	Trench FS	Page109 T9	
GT300HF120T9S	1200	300	Trench FS	Page109 T9	
GT450HF120T9S	1200	450	Trench FS	Page109 T9	
GT600HF120T9S	1200	600	Trench FS	Page109 T9	

$V_{CES}=1700V$

Part Number	Voltage(V)	Current(A)	Technology	Package Outline	Comments
沟槽型T系列-Trench T Series					
GT300HF170T9S	1700	300	Trench FS	Page109 T9	
GT450HF170T9S	1700	450	Trench FS	Page109 T9	
GT600HF170T9S	1700	600	Trench FS	Page109 T9	

Half Bridge (半桥MOSFET模块)

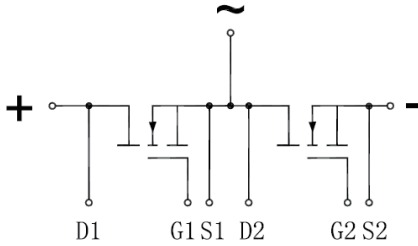
B1

$V_{DSS}=100V$

Part Number	Voltage(V)	Current(A)	RDS(on)@10V	Package Outline	Comments
MM500HF10B1S	100	500	0.93m Ω	Page103 B1	
MM700HF10B1S	100	700	0.67m Ω	Page103 B1	
MM900HF10B1S	100	900	0.53m Ω	Page103 B1	
MM1000HF10B1S	100	1000	0.40m Ω	Page103 B1	
MM1200HF10B1S	100	1200	0.33m Ω	Page103 B1	
MM1400HF10B1S	100	1400	0.29m Ω	Page103 B1	

$V_{DSS}=150V$

Part Number	Voltage(V)	Current(A)	RDS(on)@10V	Package Outline	Comments
MM340HF15B1S	150	340	3.30m Ω	Page103 B1	with FRD
MM500HF15B1S	150	500	2.00m Ω	Page103 B1	with FRD
MM680HF15B1S	150	680	1.60m Ω	Page103 B1	with FRD
MM850HF15B1S	150	850	0.90m Ω	Page103 B1	with FRD

$V_{DSS}=200V$

Part Number	Voltage(V)	Current(A)	RDS(on)@10V	Package Outline	Comments
MM450HF20B1S	200	450	2.00m Ω	Page103 B1	
MM550HF20B1S	200	550	1.60m Ω	Page103 B1	
MM650HF20B1S	200	650	1.30m Ω	Page103 B1	

Half Bridge (半桥MOSFET模块)

T2L

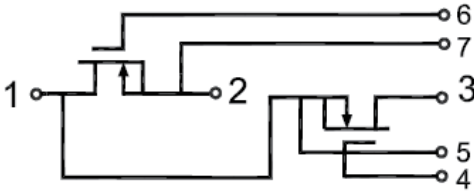

$V_{DSS}=100V$

Part Number	Voltage(V)	Current(A)	RDS(on)@10V	Package Outline	Comments
MM500HF10T2LS	100	500	0.93m Ω	Page108 T2L	
MM700HF10T2LS	100	700	0.67m Ω	Page108 T2L	
MM900HF10T2LS	100	900	0.53m Ω	Page108 T2L	
MM1000HF10T2LS	100	1000	0.40m Ω	Page108 T2L	
MM1200HF10T2LS	100	1200	0.33m Ω	Page108 T2L	
MM1400HF10T2LS	100	1400	0.29m Ω	Page108 T2L	

$V_{DSS}=150V$

Part Number	Voltage(V)	Current(A)	RDS(on)@10V	Package Outline	Comments
MM340HF15T2LS	150	340	3.30m Ω	Page108 T2L	with FRD
MM500HF15T2LS	150	500	2.00m Ω	Page108 T2L	with FRD
MM680HF15T2LS	150	680	1.60m Ω	Page108 T2L	with FRD
MM850HF15T2LS	150	850	0.90m Ω	Page108 T2L	with FRD

$V_{DSS}=200V$

Part Number	Voltage(V)	Current(A)	RDS(on)@10V	Package Outline	Comments
MM450HF20T2LS	200	450	2.00m Ω	Page108 T2L	with FRD
MM550HF20T2LS	200	550	1.60m Ω	Page108 T2L	with FRD
MM650HF20T2LS	200	650	1.30m Ω	Page108 T2L	with FRD

Full Bridge (全桥SiC MOSFET模块)

C8

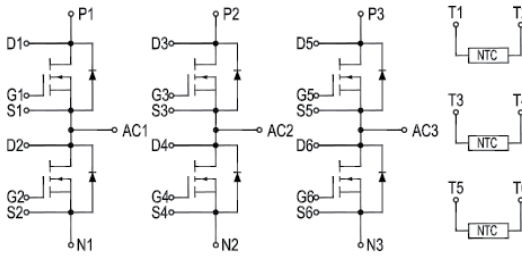

$V_{DSS}=1200V$

Part Number	Voltage(V)	Current(A)	RDS(on)@10V	Package Outline	Comments
MSC510FF120C8S	1200	510	2.6m Ω	Page105/106 C8-S04/S17	
MSC620FF120C8S	1200	620	2.2m Ω	Page105/106 C8-S04/S17	
MSC720FF120C8S	1200	720	1.9m Ω	Page105/106 C8-S04/S17	

C8N

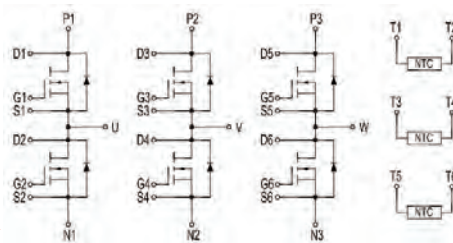

$V_{DSS}=1200V$

Part Number	Voltage(V)	Current(A)	RDS(on)@25°C	Package Outline	Comments
MSC200FF120C8NS	1200	200	8.0m Ω	Page107/108 C8N-S04/S17	
MSC300FF120C8NS	1200	300	5.3m Ω	Page107/108 C8N-S04/S17	
MSC400FF120C8NS	1200	400	4.0m Ω	Page107/108 C8N-S04/S17	

Half Bridge (半桥SiC MOSFET模块)

T2L

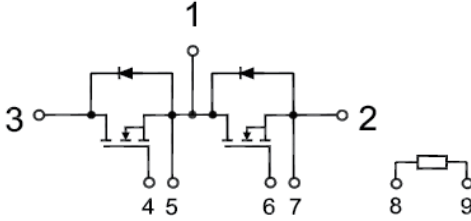

$V_{DSS}=1200V$

Part Number	Voltage(V)	Current(A)	RDS(on)@10V	Package Outline	Comments
MSC120HF120T2LS	1200	120	13mΩ	Page108 T2L	With SiC FRD
MSC160HF120T2LS	1200	160	10mΩ	Page108 T2L	With SiC FRD
MSC240HF120T2LS	1200	240	6mΩ	Page108 T2L	With SiC FRD
MSC300HF120T2LS	1200	300	5mΩ	Page108 T2L	With SiC FRD

$V_{DSS}=1700V$

Part Number	Voltage(V)	Current(A)	RDS(on)@10V	Package Outline	Comments
MSC300HF170T2LS	1700	300	8mΩ	Page108 T2L	With SiC FRD

A8

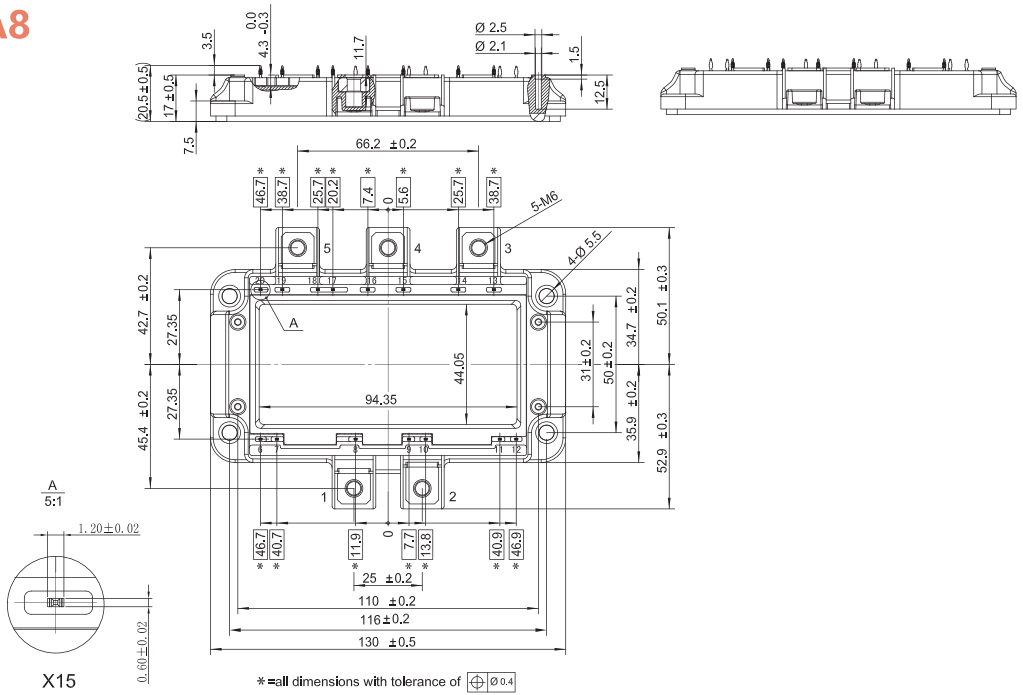

B1

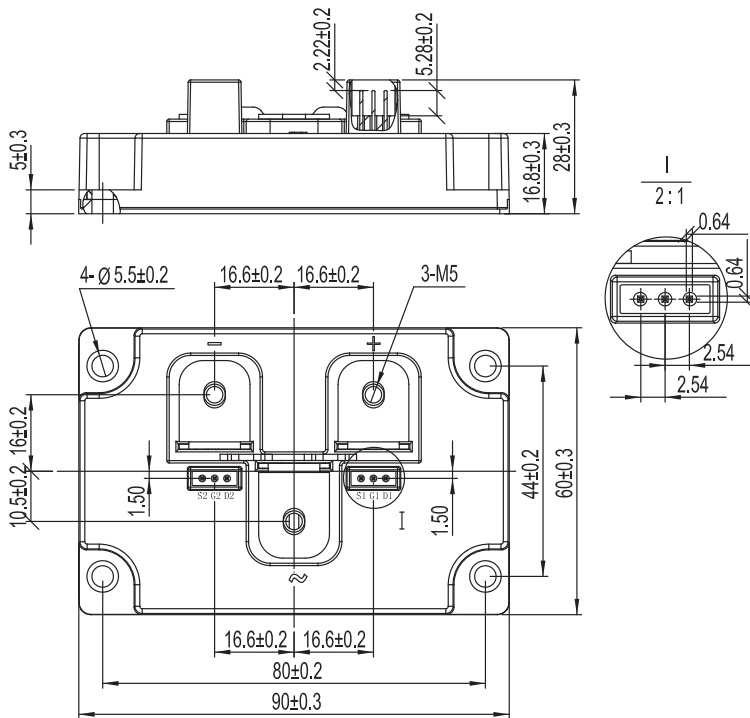

B3P-FF

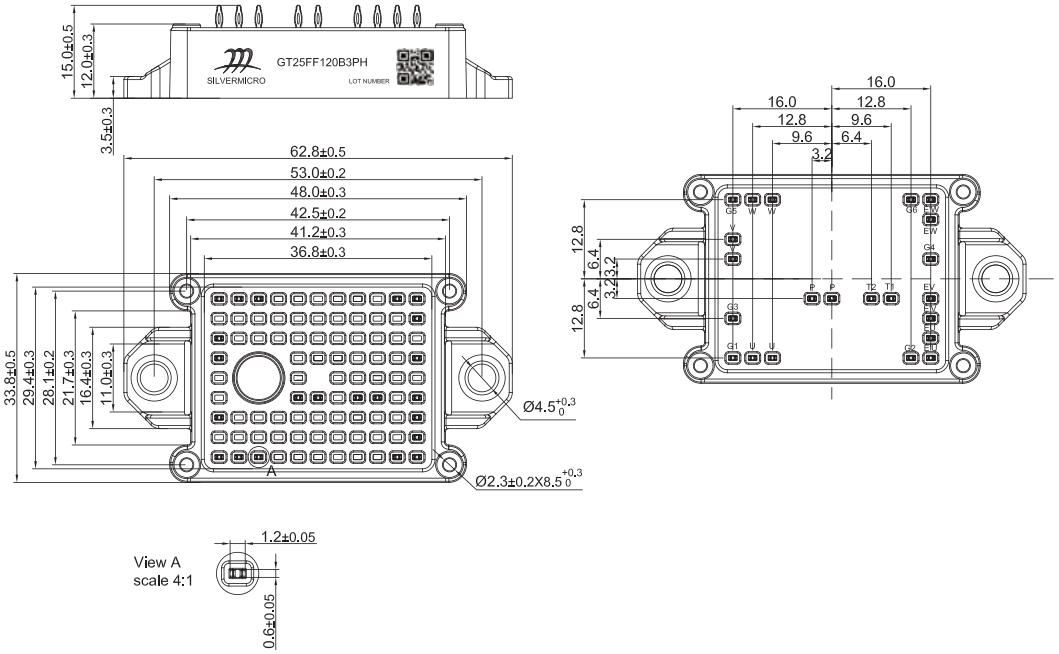

B8

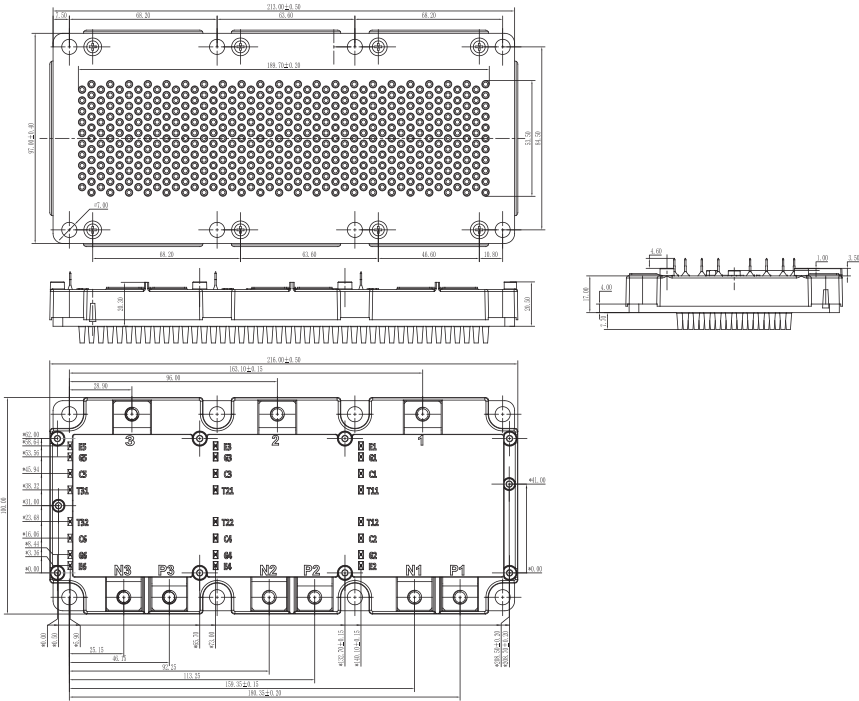

B9P-FF

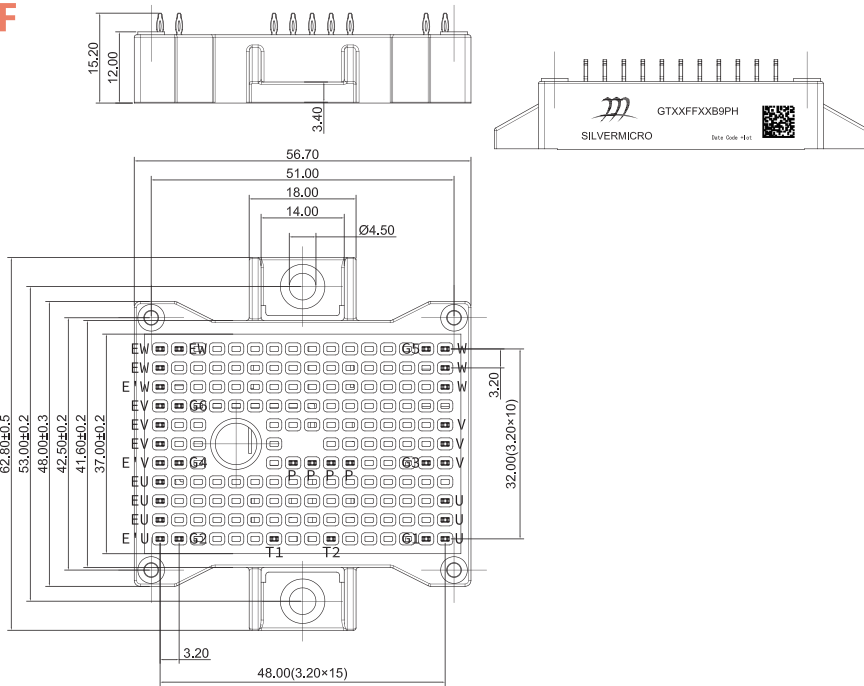

C8-S04

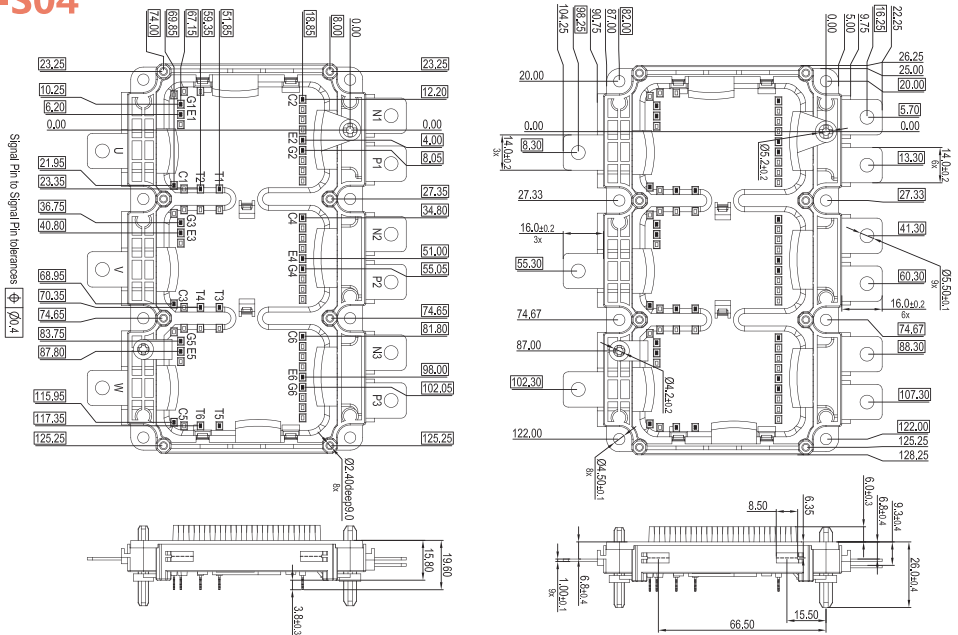

C8 S17

Signal Pin to Signal Pin Intolerance: ± 0.1

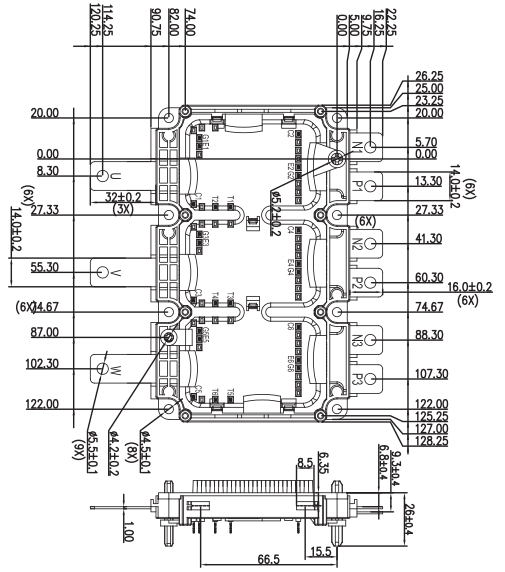
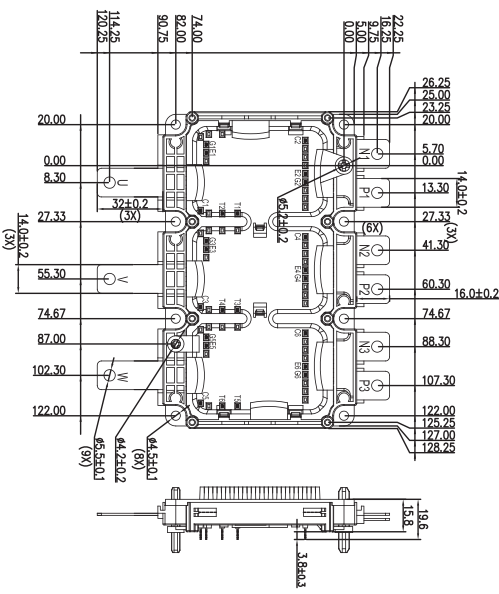

C8-S05

Signal Pin to Signal Pin Intolerance: ± 0.1

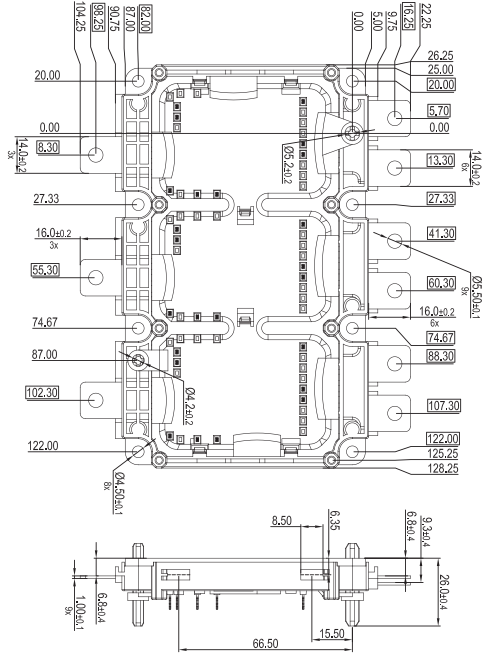
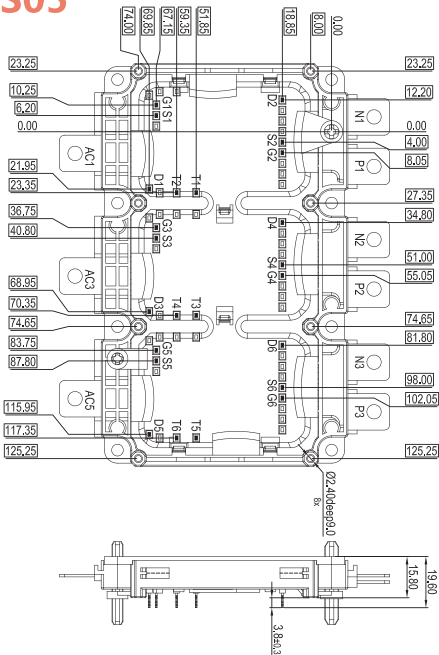

C8-S06

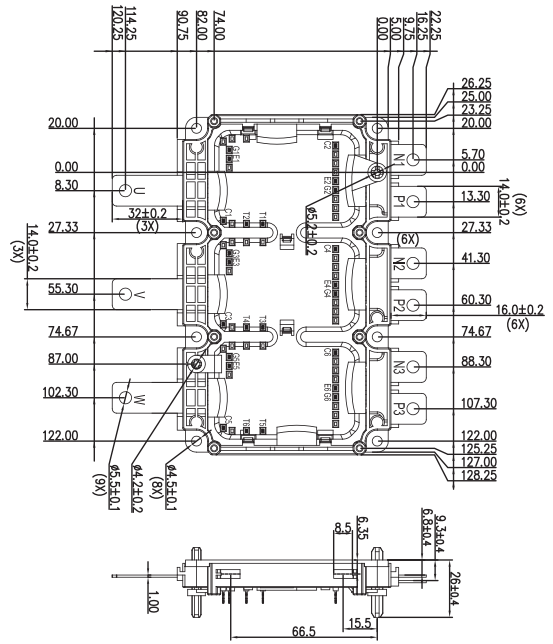
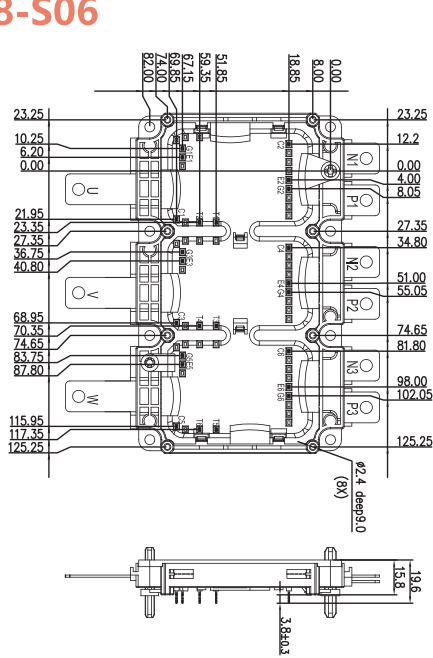

C8N-S04

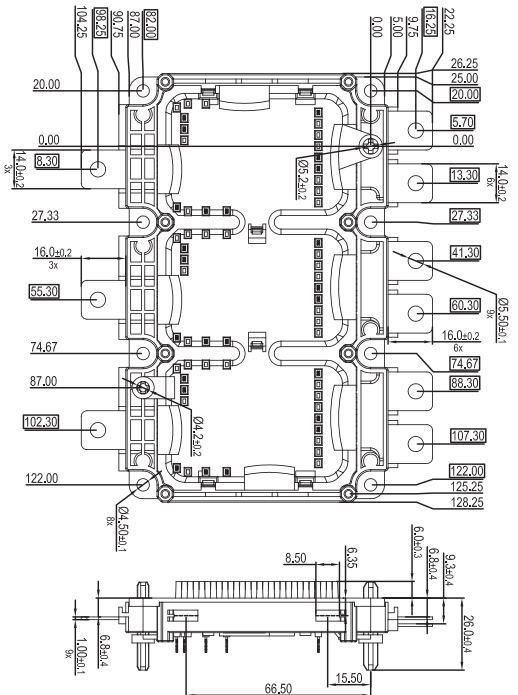
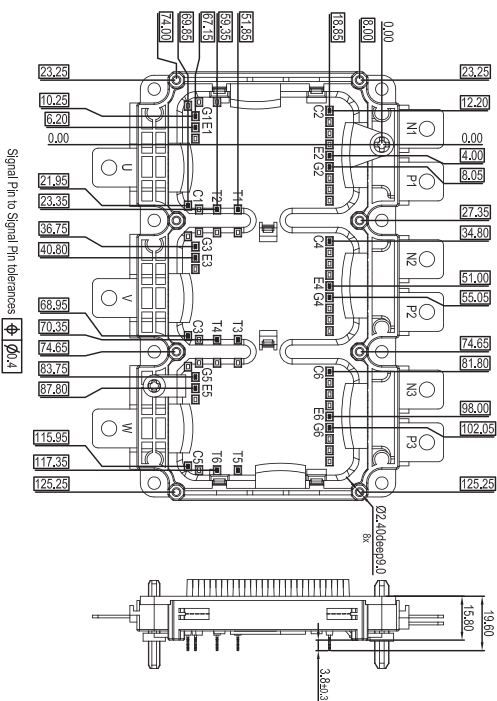

C8N-S17

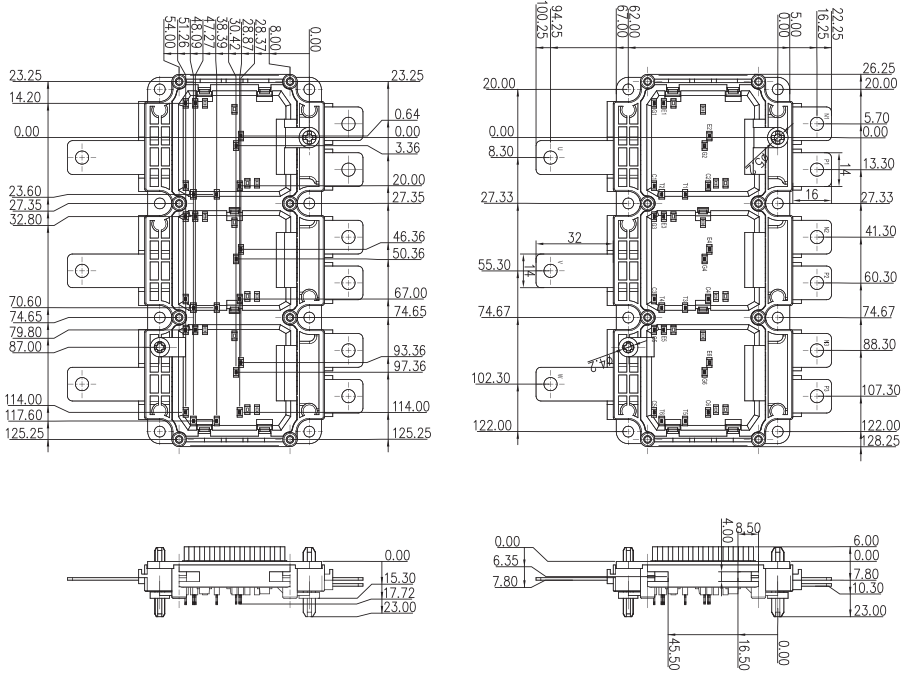

T2L

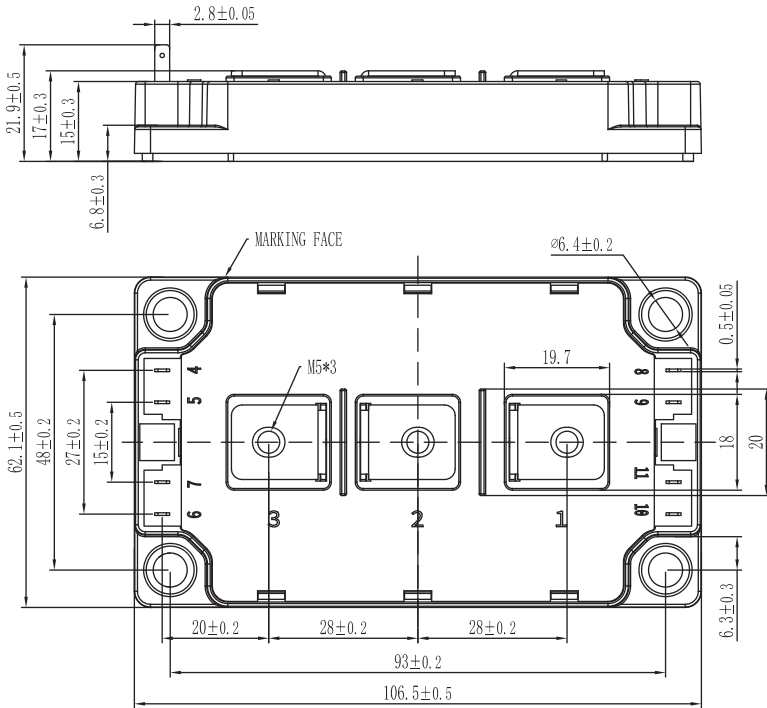

T9

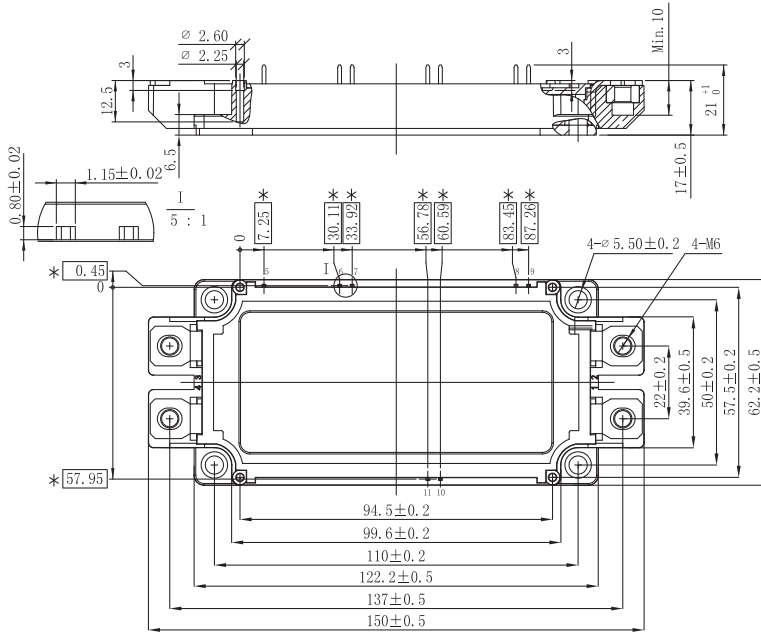

*=all dimensions with tolerance of $\varnothing 0.5$

SiC MOSFET模块

SiC MOSFET Modules

Half Bridge (半桥SiC MOSFET模块)

T2N

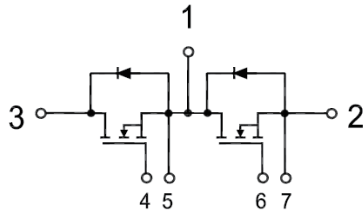
 $V_{DSS}=1200V$

Part Number	Voltage(V)	Current(A)	RDS(on)@25°C	Package Outline	Comments
MSC120HF120T2NH	1200	120	13mΩ	Page118 T2N	With SiC FRD
MSC160HF120T2NH	1200	160	10mΩ	Page118 T2N	With SiC FRD
MSC240HF120T2NH	1200	240	6mΩ	Page118 T2N	With SiC FRD
MSC300HF120T2NH	1200	300	5mΩ	Page118 T2N	With SiC FRD

 $V_{DSS}=1700V$

Part Number	Voltage(V)	Current(A)	RDS(on)@25°C	Package Outline	Comments
MSC300HF170T2NH	1700	300	8mΩ	Page118 T2N	With SiC FRD

T2L

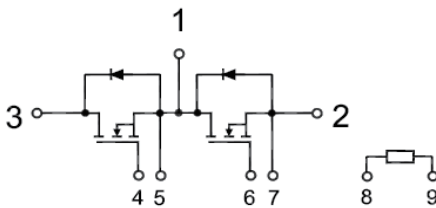
 $V_{DSS}=1200V$

Part Number	Voltage(V)	Current(A)	RDS(on)@25°C	Package Outline	Comments
MSC120HF120T2LH	1200	120	13mΩ	Page117 T2L	With SiC FRD
MSC160HF120T2LH	1200	160	10mΩ	Page117 T2L	With SiC FRD
MSC240HF120T2LH	1200	240	6mΩ	Page117 T2L	With SiC FRD
MSC300HF120T2LH	1200	300	5mΩ	Page117 T2L	With SiC FRD

Half Bridge (半桥SiC MOSFET模块)

T2L

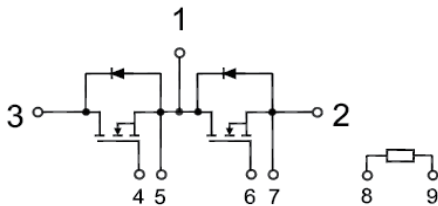

$V_{DSS}=1700V$

Part Number	Voltage(V)	Current(A)	RDS(on)@25°C	Package Outline	Comments
MSC300HF170T2LH	1700	300	8mΩ	Page117 T2L	With SiC FRD

B9

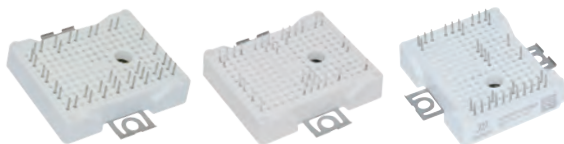
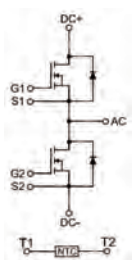

$V_{DSS}=1200V$

Part Number	Voltage(V)	Current(A)	RDS(on)@10V	Package Outline	Comments
MSC150HF120B9H	1200	150	8.8mΩ	Page116 B9-HF	With SiC FRD

Full Bridge (全桥SiC MOSFET模块)

C7

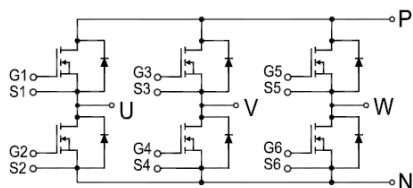

$V_{DSS}=1200V$

Part Number	Voltage(V)	Current(A)	RDS(on)@25°C	Package Outline	Comments
MSC20FF120C7H	1200	20	80mΩ	Page117 C7-FF	With SiC FRD
MSC50FF120C7H	1200	50	25mΩ	Page117 C7-FF	With SiC FRD

Full Bridge (全桥SiC MOSFET模块)

T5

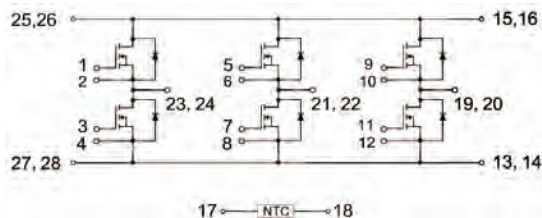

$V_{DSS}=1200V$

Part Number	Voltage(V)	Current(A)	RDS(on)@25°C	Package Outline	Comments
MSC20FF120T5H	1200	20	80mΩ	Page118 T5-FF	With SiC FRD
MSC50FF120T5H	1200	50	25mΩ	Page118 T5-FF	With SiC FRD

$V_{DSS}=1700V$

Part Number	Voltage(V)	Current(A)	RDS(on)@25°C	Package Outline	Comments
MSC50FF170T5H	1700	50	45mΩ	Page118 T5-FF	With SiC FRD

Single Phase Rectifier Bridge 单相整流模块

B3

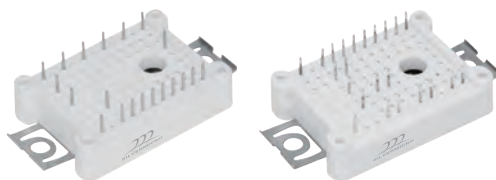
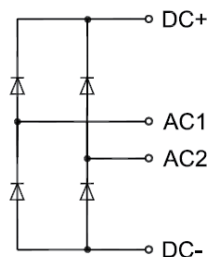

$V_{DSS}=600V$

Part Number	Voltage(V)	Current(A)	RDS(on)@25°C	Package Outline	Comments
RD30FH60B3H	600	30	SiC Schottky diode	Page115 B3-FH	

$V_{DSS}=1200V$

Part Number	Voltage(V)	Current(A)	RDS(on)@25°C	Package Outline	Comments
RD30FH120B3H	1200	30	SiC Schottky diode	Page115 B3-FH	

Three level 三电平SiC MOSFET模块

A8

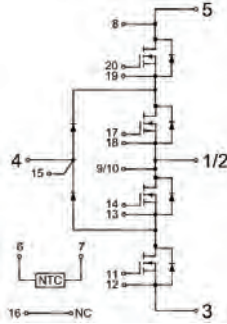

$V_{DSS}=650V$

Part Number	Voltage(V)	Current(A)	RDS(on)@25°C	Package Outline	Comments
MSC150TL65A8H	650	150	10.0mΩ	Page115 A8	
MSC200TL65A8H	650	200	7.5mΩ	Page115 A8	
MSC300TL65A8H	650	300	4.4mΩ	Page115 A8	
MSC400TL65A8H	650	400	3.4mΩ	Page115 A8	

Three level 三电平SiC MOSFET模块

B9

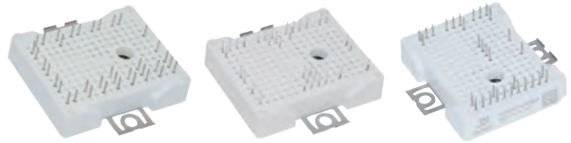
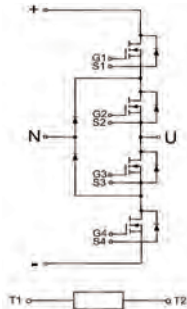

$V_{DSS}=650V$

Part Number	Voltage(V)	Current(A)	RDS(on)@25°C	Package Outline	Comments
MSC150TL65B9H	650	150	10mΩ	Page116 B9-TL	

C7-FF

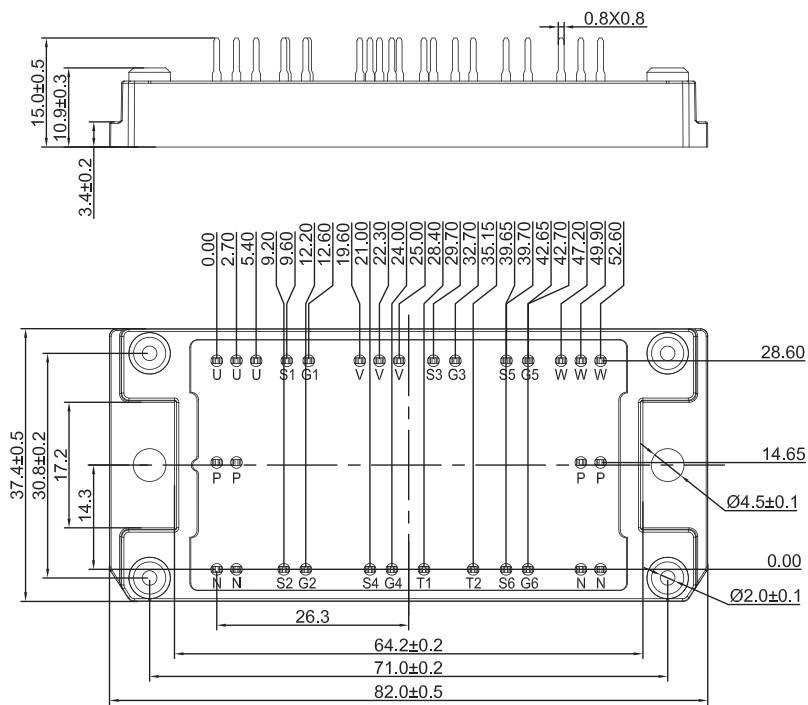

T2L

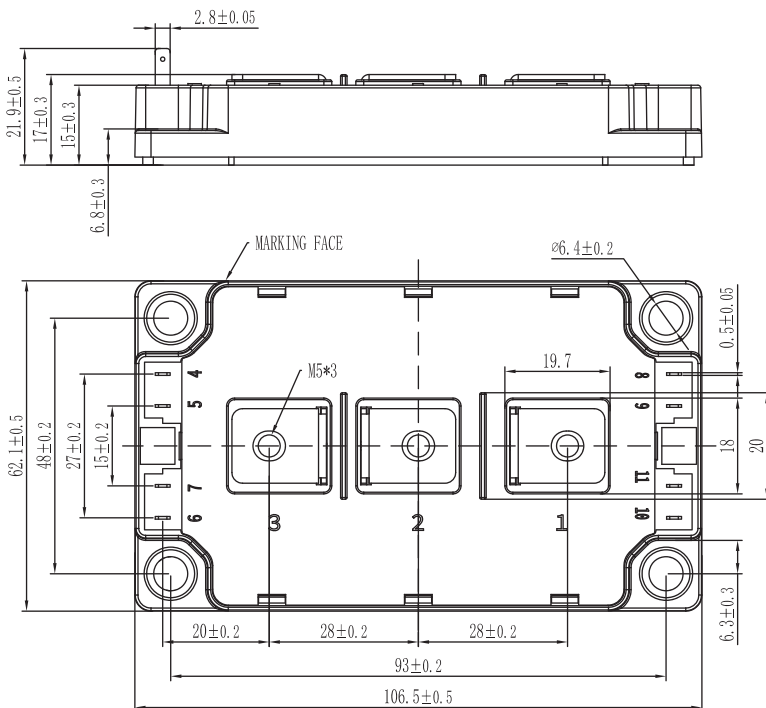

GaN模块

Full Bridge (全桥GaN模块)

C8B

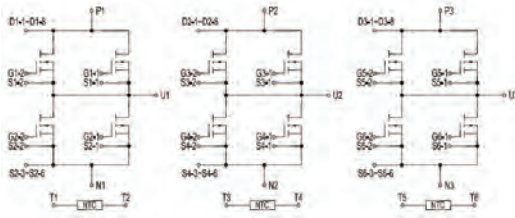

$V_{RRM}=650V$

Part Number	Voltage(V)	Current(A)	RDS(on)@25°C	Package Outline	Comments
MGN300FF65C8BH	650	300	4mΩ	Page120 C8B-FF	

C8B

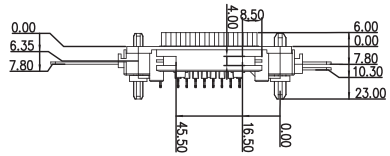
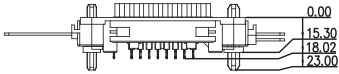
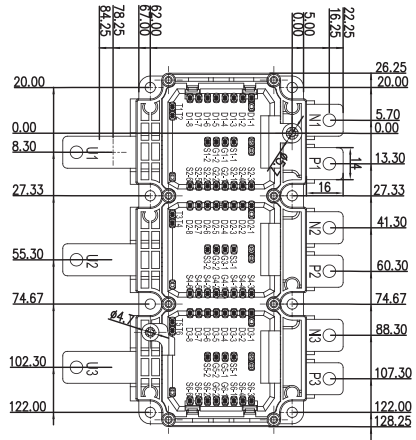
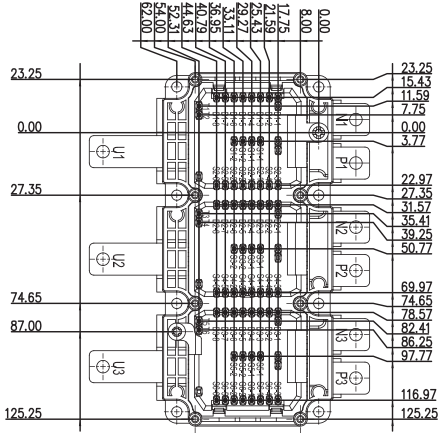

快恢二极管模块

Diode Modules

Half Bridge (半桥二极管模块)

A9

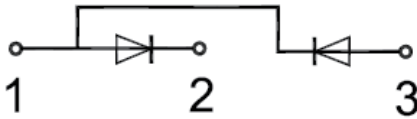

$V_{RRM}=1200V$

Part Number	Voltage(V)	Current(A)	Technology	Package Outline	Comments
DD100HF120A9H	1200	100	High Voltage Planar Diode	Page124 A9	fast recovery
DD150HF120A9H	1200	150	High Voltage Planar Diode	Page124 A9	fast recovery
DD200HF120A9H	1200	200	High Voltage Planar Diode	Page124 A9	fast recovery

T1W

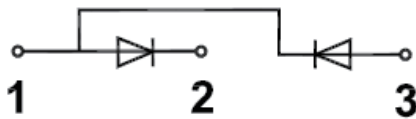

$V_{RRM}=1200V$

Part Number	Voltage(V)	Current(A)	Technology	Package Outline	Comments
DD100HF120T1WH	1200	100	High Voltage Planar Diode	Page124 T1W	fast recovery
DD150HF120T1WH	1200	150	High Voltage Planar Diode	Page124 T1W	fast recovery
DD200HF120T1WH	1200	200	High Voltage Planar Diode	Page124 T1W	fast recovery

$V_{RRM}=1700V$

Part Number	Voltage(V)	Current(A)	Technology	Package Outline	Comments
DD100HF170T1WH	1700	100	High Voltage Planar Diode	Page124 T1W	fast recovery
DD150HF170T1WH	1700	150	High Voltage Planar Diode	Page124 T1W	fast recovery

Single Diode (单管二极管模块)

A9

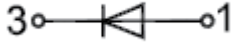

$V_{RRM} = 1200V$

Part Number	Voltage(V)	Current(A)	Technology	Package Outline	Comments
DD100SD120A9H	1200	100	High Voltage Planar Diode	Page124 A9	fast recovery
DD150SD120A9H	1200	150	High Voltage Planar Diode	Page124 A9	fast recovery
DD200SD120A9H	1200	200	High Voltage Planar Diode	Page124 A9	fast recovery
DD300SD120A9H	1200	300	High Voltage Planar Diode	Page124 A9	fast recovery

Single Diode (单管二极管模块)

T1W



$V_{RRM} = 1200V$

Part Number	Voltage(V)	Current(A)	Technology	Package Outline	Comments
DD100SD120T1WH	1200	100	High Voltage Planar Diode	Page124 T1W	fast recovery
DD150SD120T1WH	1200	150	High Voltage Planar Diode	Page124 T1W	fast recovery
DD200SD120T1WH	1200	200	High Voltage Planar Diode	Page124 T1W	fast recovery
DD300SD120T1WH	1200	300	High Voltage Planar Diode	Page124 T1W	fast recovery
DD400SD120T1WH	1200	400	High Voltage Planar Diode	Page124 T1W	fast recovery

Single Diode (单管二极管模块)

T1W



$V_{RRM} = 1700V$

Part Number	Voltage(V)	Current(A)	Technology	Package Outline	Comments
DD100SD170T1WH	1700	100	High Voltage Planar Diode	Page124 T1W	fast recovery
DD150SD170T1WH	1700	150	High Voltage Planar Diode	Page124 T1W	fast recovery
DD200SD170T1WH	1700	200	High Voltage Planar Diode	Page124 T1W	fast recovery
DD300SD170T1WH	1700	300	High Voltage Planar Diode	Page124 T1W	fast recovery

Common Cathode (共阴极二极管模块)

A9

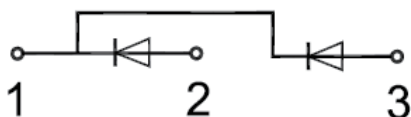

$V_{RRM} = 1200V$

Part Number	Voltage(V)	Current(A)	Technology	Package Outline	Comments
DD100CK120A9H	1200	100	High Voltage Planar Diode	Page124 A9	fast recovery
DD150CK120A9H	1200	150	High Voltage Planar Diode	Page124 A9	fast recovery
DD200CK120A9H	1200	200	High Voltage Planar Diode	Page124 A9	fast recovery

整流模块

Rectifier Modules

Half Bridge Rectifier Diode Modules (半桥整流二极管模块)

A9

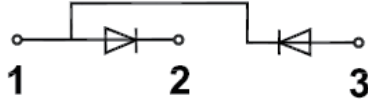

$V_{RRM}=1800V$

Part Number	Voltage(V)	Current(A)	Technology	Package Outline	Comments
RD70HF180A9HJ	1800	70	Inside Moat Mesa Diodes	Page129 A9	
RD100HF180A9HJ	1800	100	Inside Moat Mesa Diodes	Page129 A9	
RD120HF180A9HJ	1800	120	Inside Moat Mesa Diodes	Page129 A9	

T1W

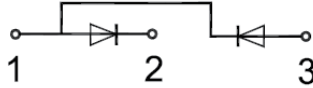

$V_{RRM}=1800V$

Part Number	Voltage(V)	Current(A)	Technology	Package Outline	Comments
RD165HF180T1WHJ	1800	165	Inside Moat Mesa Diodes	Page132 T1W	
RD200HF180T1WHJ	1800	200	Inside Moat Mesa Diodes	Page132 T1W	
RD230HF180T1WHJ	1800	230	Inside Moat Mesa Diodes	Page132 T1W	
RD300HF180T1WHJ	1800	300	Inside Moat Mesa Diodes	Page132 T1W	

Common Cathode Rectifier Diode Modules (共阴极整流二极管模块)

A9

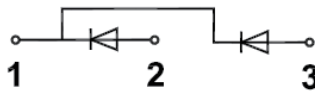

$V_{RRM}=1800V$

Part Number	Voltage(V)	Current(A)	Technology	Package Outline	Comments
RD70CK180A9HJ	1800	70	Inside Moat Mesa Diodes	Page129 A9	
RD100CK180A9HJ	1800	100	Inside Moat Mesa Diodes	Page129 A9	
RD120CK180A9HJ	1800	120	Inside Moat Mesa Diodes	Page129 A9	

Common Cathode Rectifier Diode Modules (共阴极整流二极管模块)

T1W

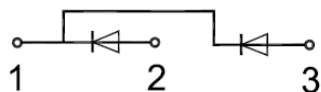
 $V_{RRM}=1800V$

Part Number	Voltage(V)	Current(A)	Technology	Package Outline	Comments
RD165CK180T1WHJ	1800	165	Inside Moat Mesa Diodes	Page132 T1W	
RD200CK180T1WHJ	1800	200	Inside Moat Mesa Diodes	Page132 T1W	
RD230CK180T1WHJ	1800	230	Inside Moat Mesa Diodes	Page132 T1W	
RD300CK180T1WHJ	1800	300	Inside Moat Mesa Diodes	Page132 T1W	

Three Phase Rectifier Bridge (三相整流模块)

C1

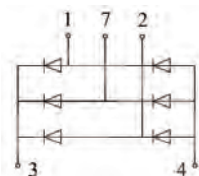
 $V_{RRM}=1800V$

Part Number	Voltage(V)	Current(A)	Technology	Package Outline	Comments
RD30FF180C1HJ	1800	30	Inside Moat Mesa Diodes	Page129 C1	
RD50FF180C1HJ	1800	50	Inside Moat Mesa Diodes	Page129 C1	
RD75FF180C1HJ	1800	75	Inside Moat Mesa Diodes	Page129 C1	

C2

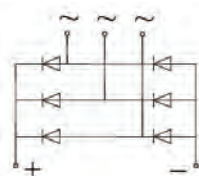
 $V_{RRM}=1800V$

Part Number	Voltage(V)	Current(A)	Technology	Package Outline	Comments
RD52FF180C2HJ	1800	52	Inside Moat Mesa Diodes	Page130 C2	
RD75FF180C2HJ	1800	75	Inside Moat Mesa Diodes	Page130 C2	
RD100FF180C2HJ	1800	100	Inside Moat Mesa Diodes	Page130 C2	
RD130FF180C2HJ	1800	130	Inside Moat Mesa Diodes	Page130 C2	

Three Phase Rectifier Bridge (三相整流模块)

C3

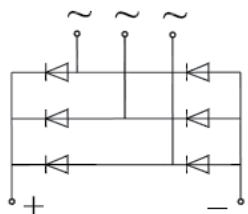

$V_{RRM}=1800V$

Part Number	Voltage(V)	Current(A)	Technology	Package Outline	Comments
RD100FF180C3HJ	1800	100	Inside Moat Mesa Diodes	Page130 C3	
RD130FF180C3HJ	1800	130	Inside Moat Mesa Diodes	Page130 C3	
RD160FF180C3HJ	1800	160	Inside Moat Mesa Diodes	Page130 C3	
RD200FF180C3HJ	1800	200	Inside Moat Mesa Diodes	Page130 C3	
RD250FF180C3HJ	1800	250	Inside Moat Mesa Diodes	Page130 C3	

Three Phase Rectifier Bridge+Thyristor (三相整流+SCR模块)

C4

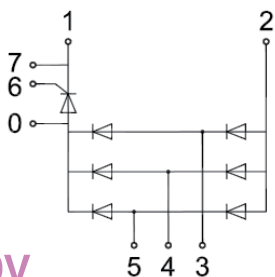

$V_{RRM}=1800V$

Part Number	Voltage(V)	Current(A)	Technology	Package Outline	Comments
RD100FFS180C4HJ	1800	100	Inside Moat Mesa Diodes	Page131 C4	with SCR

Three Phase Rectifier Bridge+Thyristor (三相整流+SCR模块)

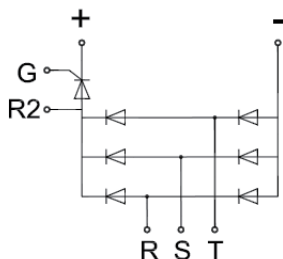
C5

 $V_{RRM}=1800V$

Part Number	Voltage(V)	Current(A)	Technology	Package Outline	Comments
RD150FFS180C5HJ	1800	150	Inside Moat Mesa Diodes	Page131 C5	with SCR
RD200FFS180C5HJ	1800	200	Inside Moat Mesa Diodes	Page131 C5	with SCR

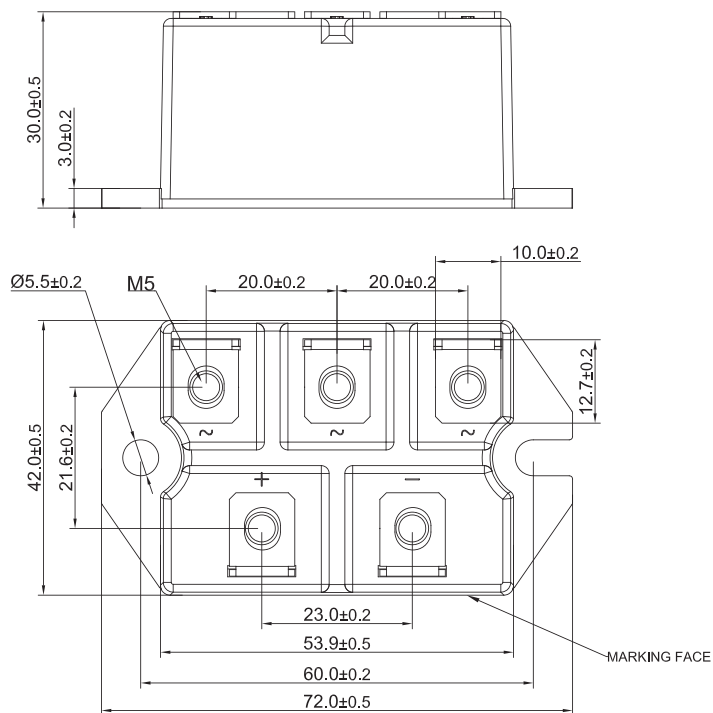
C2

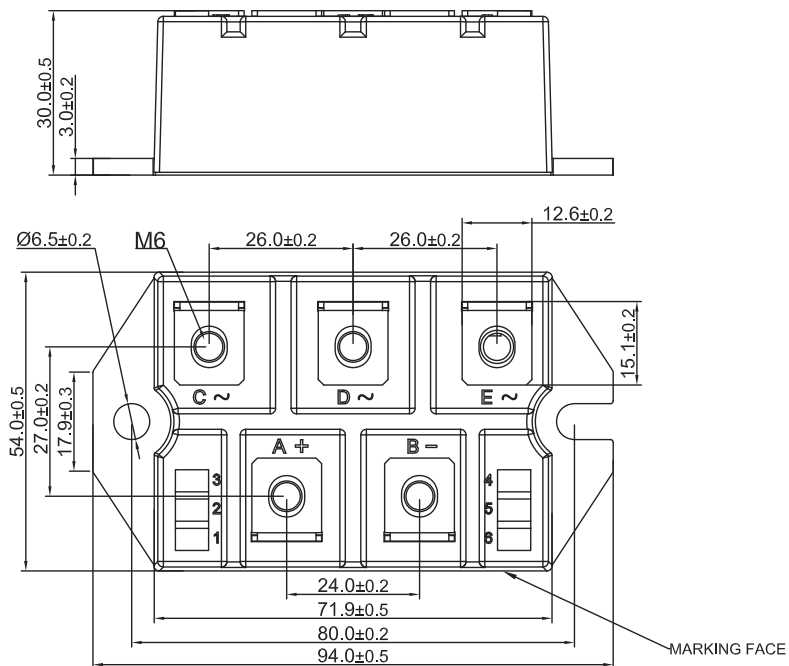

C3



C4

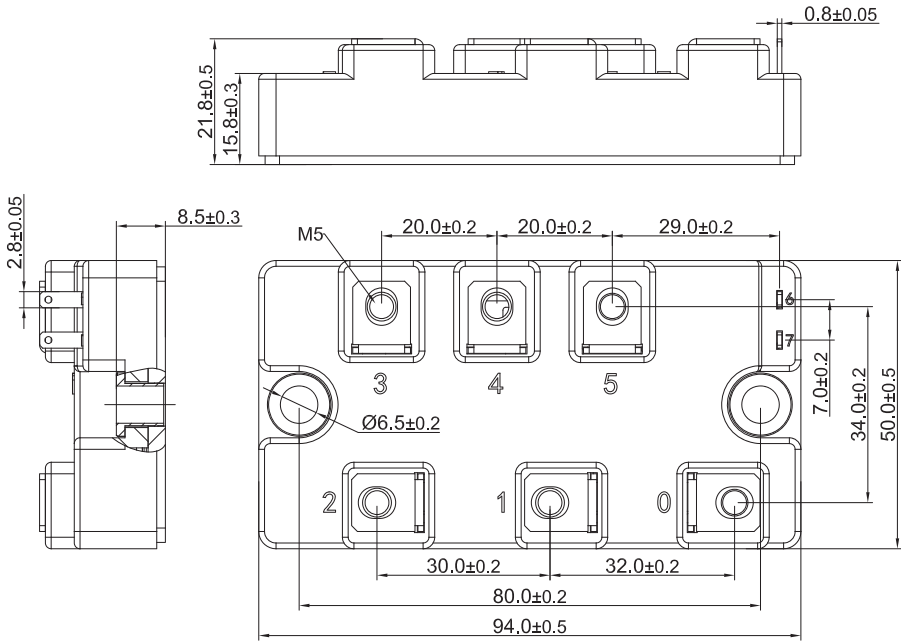

C5

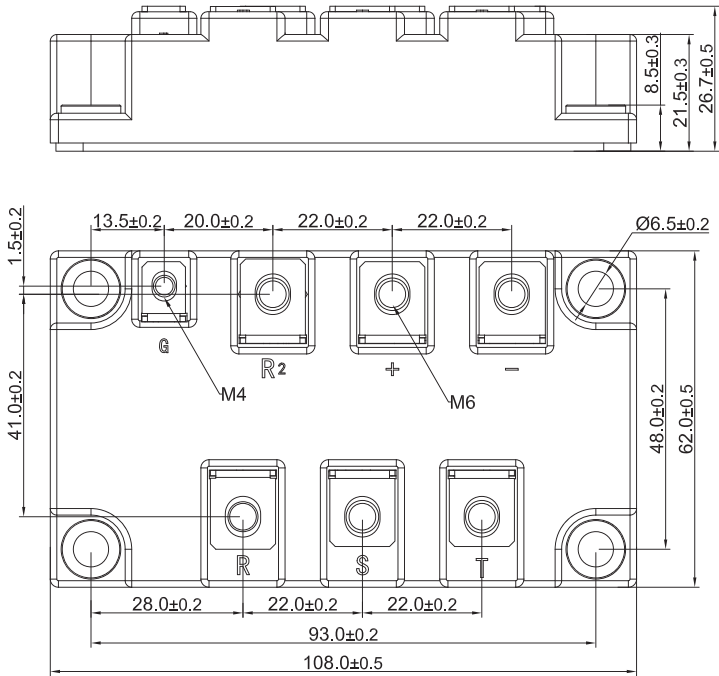

T1W

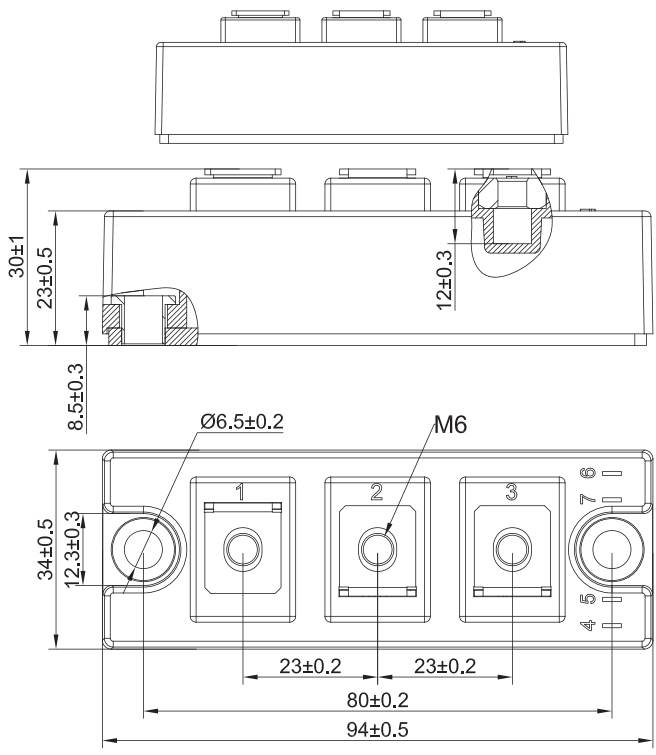

晶闸管模块

Thyristor(SCR) Modules

Half Bridge (半桥SCR模块)

A9

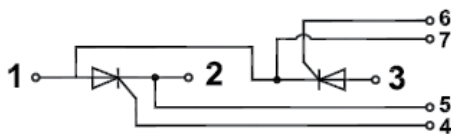

$V_{RRM} / V_{DRM} = 1800V$

Part Number	Voltage(V)	Current(A)	Technology	Package Outline	Comments
RS60HF180A9HJ	1800	60	Double Mesa Center Gate Structure Reverse Blocking High Voltage Thyristor	Page135 A9	
RS90HF180A9HJ	1800	90	Double Mesa Center Gate Structure Reverse Blocking High Voltage Thyristor	Page135 A9	
RS110HF180A9HJ	1800	110	Double Mesa Center Gate Structure Reverse Blocking High Voltage Thyristor	Page135 A9	

T1W

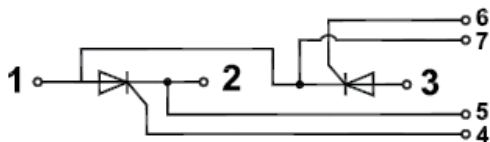

$V_{RRM} / V_{DRM} = 1800V$

Part Number	Voltage(V)	Current(A)	Technology	Package Outline	Comments
RS130HF180T1WHJ	1800	130	Double Mesa Center Gate Structure Reverse Blocking High Voltage Thyristor	Page135 T1W	
RS160HF180T1WHJ	1800	160	Double Mesa Center Gate Structure Reverse Blocking High Voltage Thyristor	Page135 T1W	

Half Bridge (半桥SCR模块)

P2

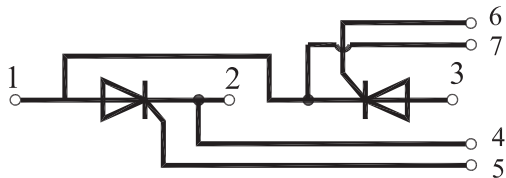

$V_{RRM} / V_{DRM} = 1800V$

Part Number	Voltage(V)	Current(A)	Technology	Package Outline	Comments
RS320HF180P2HJ	1800	320	Double Mesa Center Gate Structure Reverse Blocking High Voltage Thyristor	Page136 P2	

P2

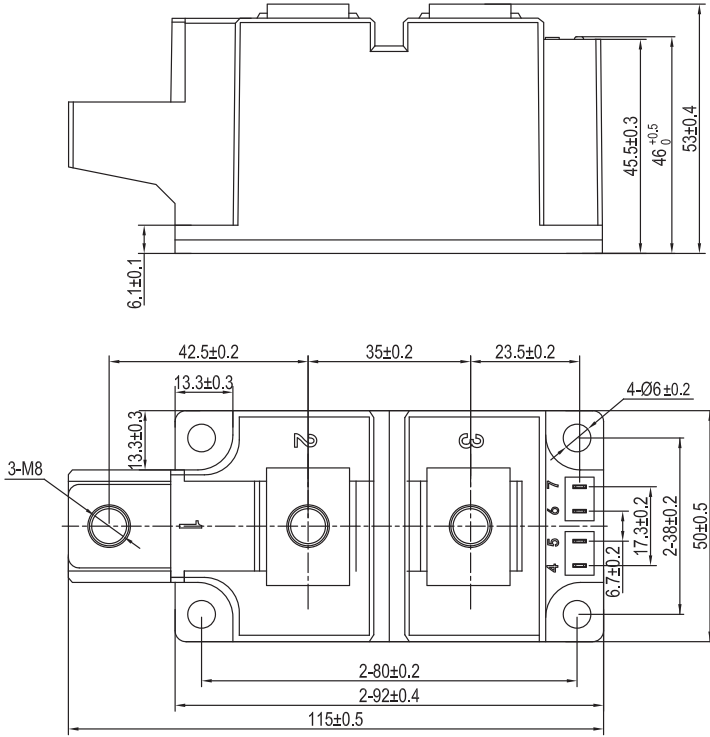

Represented by



alfatec

alfatec GmbH & Co. KG
Meckenloher Straße 11
91126 Rednitzhembach
Germany

Tel: +49 (0) 9122 / 97 96 - 0
Fax: +49 (0) 9122 / 97 96 - 50
E-Mail: info@alfatec.de
Web: www.alfatec.de

地 址: 江苏省南京市溧水经济开发区秀山西路9号银茂工业园

网 址: <http://www.njsme.com>

南京总部: 025-56612118 FAX:025-56612119
15366077001

上浙:15366077003

华东:15366078554

中原:15366077009

华南:15366077065

华北:15366077087

西南:15366077008

Sales Representatives :

North America Mightronics

+001 702-435-0188

Europe Alfatec

+49 (0) 9122 9796-0

Japan All Nippon Airways Trading Co.

+81-3-6735-5011

Taiwan Wealth Source Power Electronics Technology Corp.

+886-955-007-484